

INDEX	SAS000903
REV. LEVEL	2
SHEET	1 OF 1

TOSHIBA/HOUSTON

TOTALLY-ENCLOSED FAN COOLED
HORIZONTAL FOOT-MOUNTED

Fr. 213T-215T

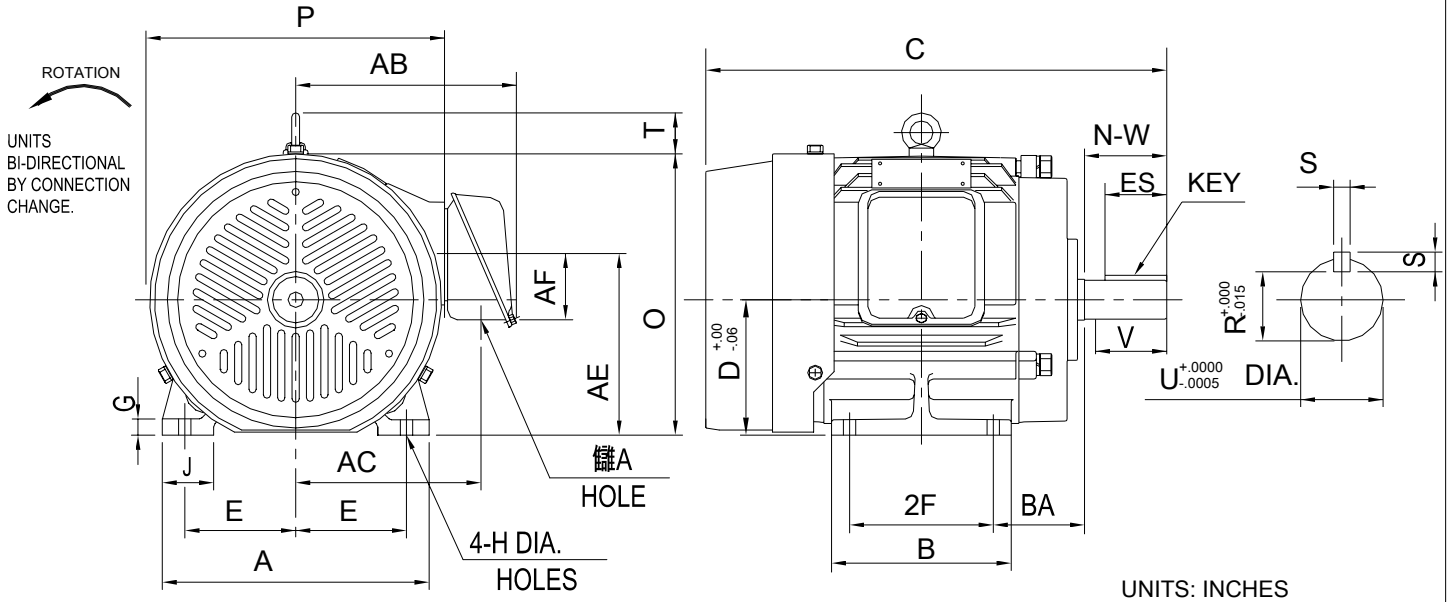

UNITS: INCHES

FRAME SIZE	MOUNTING				CONDUIT BOX						
	E	2F	H	BA	AA	AB	AC	AE	AF	XL	XN
213T	4.25	5.50	0.41	3.50	1.38	8.39	7.2	6.97	2.61	—	—
215T	4.25	7.00	0.41	3.50	1.38	8.39	7.2	6.97	2.61	—	—

FRAME SIZE	MOTOR DIMENSIONS									
	A	B	C	D	G	J	M	O	T	P
213T	10.24	6.89	17.94	5.25	0.65	1.97	—	10.84	1.65	10.55
215T	10.24	8.39	19.43	5.25	0.65	1.97	—	10.84	1.65	10.55

FRAME SIZE	SHAFT EXTENSION			KEY SEAT			BEARINGS		MAXIMUM WEIGHT
	N-W	V	U	R	S	ES	LS	OS	
213T/215T	3.38	3.12	1.375	1.201	0.312	2.41	6308ZZ	6208ZZ	180 lbs.

ALL DATA SUBJECT TO CHANGE WITHOUT NOTICE.
FOR CONSTRUCTION USE ONLY CERTIFIED DATA.

NOTES:

1. DIMENSION V REPRESENTS LENGTH OF STRAIGHT PART OF SHAFT
2. CONDUIT BOX MAY BE ROTATED IN 90° INCREMENTS AND MAY BE MOUNTED ON OPPOSITE SIDE ON SPECIAL ORDER.
3. KEY DIMENSIONS EQUAL S x S x 2.41 (MOTOR SUPPLIED WITH KEY)
4. MOTOR WEIGHT SHOWN IS MAXIMUM HORSEPOWER IN FRAME.

CERTIFIED DATA

CUSTOMER: _____ P.O. NO.: _____ TAG NO.: _____

MOTOR MODEL NO.: **0104FTCA21A-P** TOSHIBA FILE NO.: _____

HP: **10** RPM (SYN.): **1800** VOLTAGE: **230/460** Hz: **60**

FRAME SIZE: **215T** LOG NO.: _____ LOG REV. LEVEL: _____

REMARKS: _____

PER: _____ ISSUE DATE: _____ SUPERSEDES: _____

TOSHIBA INTERNATIONAL CORPORATION
Industrial Division / Houston Motor Plant

**SQUIRREL CAGE INDUCTION MOTOR
 PERFORMANCE SPECIFICATIONS**

INDEX	MPCF-1033
SHEET NO.	1 of 1
ISSUED	11/08/96
SUPERSEDES	10/06/95
REVISION	1
WRITTEN BY	R. EVANS
APPROVED BY	<i>Jay Bugbee</i>

Customer Tag:

CUSTOMER:
 TIC SR No.:
 Customer PO:

MOTOR NAMEPLATE DATA

H.P.: 10	VOLTS: 230/460	3 Ø / 60	Hz	S. RPM: 1800
FRAME: 215T	ENCL: TEFC	FLAMPS: 12.6		FLRPM: 1760
FORM: FBK1	S.F.: 1.15	NEMA DESIGN: C		INSUL CLASS: F
TYPE: IKK	AMB.: 40C	CODE: H		DUTY: CONT.
MODEL No.: 0104FTCA21A-P		kW: 7.5		Serial No.:
NOM. EFF.: 89.5	MIN. EFF.:	P.F.: 83.5		

AMPERAGE Locked Rotor: 81	TORQUES FULL LOAD (lb-ft.): 29.80 LOCKED ROTOR (%): 250 BREAK DOWN (%): 270	** BEARINGS: Drive End: 6208ZZ Opposite Drive End: 6308ZZ
-------------------------------------	---	--

EFFICIENCY (%) FULL LOAD: 89.5 3/4 LOAD: 90.0 1/2 LOAD: 89.5	POWER FACTOR (%) FULL LOAD: 83.5 3/4 LOAD: 80.0 1/2 LOAD: 70.5
--	--

ALL CHARACTERISTICS ARE AVERAGE EXPECTED VALUES BASED UPON RATED VOLTAGE, FREQUENCY AND SINEWAVE POWER INPUT.

* TEMPERATURE RISE WILL BE CONSISTENT WITH INSULATION, AMBIENT AND SERVICE FACTOR AS DEFINED BY NEMA-MG-12.43 OR -20.40.

** BEARINGS ARE THE ONLY RECOMMENDED SPARE PART(S).

CERTIFIED BY:
DATE:

TOSHIBA

Reliability in Motion

TOSHIBA INTERNATIONAL CORPORATION

INDUSTRIAL DIVISION

PO BOX 40906

HOUSTON TX 77240

(713) 466-0277

(800) 231-1412

FAX (713) 466-8773

SPARE PARTS (RECOMMENDED)

OTHER THAN THE GREASE USED FOR RE-GREASABLE BEARINGS, **TOSHIBA** ADVISES THAT THERE ARE NO "USE" PARTS. THE ONLY INSURANCE SPARES THAT **TOSHIBA** SUGGESTS FOR THESE SQUIRREL CAGE INDUCTION MOTORS ARE INDUSTRY STANDARD, AND COMMERCIALY AVAILABLE ANTI-FRICTION BEARINGS, AS NOTED BELOW.

MOTOR COMPONENTS (SUCH AS TERMINAL BOXES, FAN COVERS, MACHINED PARTS) ARE AVAILABLE UPON SPECIAL REQUEST. IN THIS CASE, PLEASE ADVISE OUR ORDER ENTRY DEPARTMENT THE MODEL AND SERIAL NUMBERS (FOUND ON THE MOTOR NAMEPLATE) , AND A DESCRIPTION OF THE COMPONENT REQUIRED. THEY WILL THEN FURNISH THE CURRENT PART NUMBER, PRICE AND AVAILABILITY.

(NOTE: OUR INTERNAL PART NUMBERS ARE SUBJECT TO CHANGE WITHOUT NOTICE, AND ARE NOT PUBLISHED).

PLEASE ADVISE IF YOU HAVE ANY QUESTIONS.

CUSTOMER:
PURCHASE ORDER #
Customer Tag:

TOSHIBA FILE #
MODEL # 0104FTCA21A-P
HP / RPM / ENCL / FRAME: 10 / 1800 / TEFC / 215T
DRIVE END BEARING: 6208ZZ
OPPOSITE DRIVE END BEARING: 6308ZZ

Prepared By:
Date:

Three Phase Motor Wiring Diagram
"Across the line" (Full Voltage) Starting

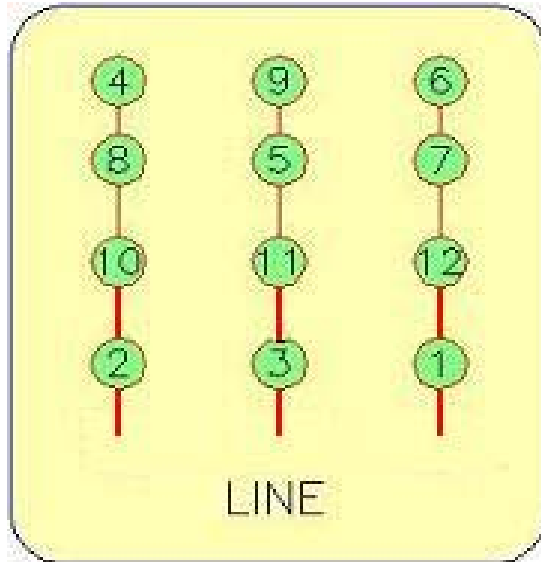

Customer Name:	
PO No.:	
Customer Tag:	
TIC File No.:	
Motor Model No.	0104FTCA21A-P

For Further Information Regarding Toshiba motor starting, maintenance or wiring, Please refer to the "Toshiba - A Quality Product for World Energy" Installation and Maintenance Manual, or contact the Toshiba Low Voltage Motor Marketing Department. (800) 231-1412

Prepared By:
Date: