

INDEX	SAS001199
REV. LEVEL	0
SHEET	1 OF 1

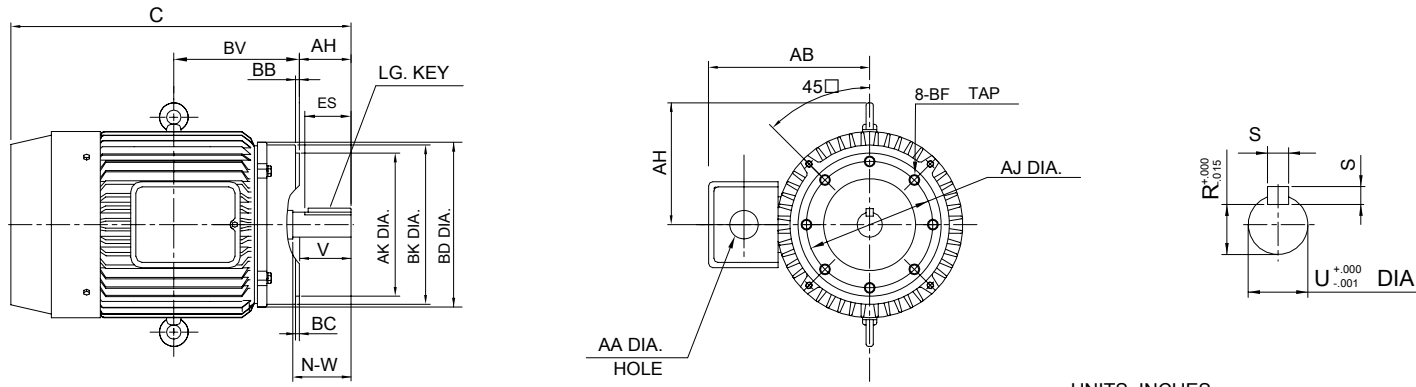

UNITS: INCHES

- NOTES:
1. DIMENSION V REPRESENTS LENGTH OF STRAIGHT PART OF SHAFT.
  2. CONDUIT BOX MAY BE ROTATED IN 90° INCREMENTS AND MAY BE MOUNTED ON OPPOSITE SIDE ON SPECIAL ORDER.
  3. "T" KEY DIMENSIONS EQUAL S x S x 3.88 "TS" KEY DIMENSIONS EQUAL S x S x 2.00 (MOTOR SUPPLIED WITH KEY)
  4. MOTOR WEIGHT SHOWN IS MAXIMUM HORSEPOWER IN FRAME.

FRAME SIZE	FLANGE					
	AJ	AK	BB	BD	BF TAP	BV
364TC/364TSC	11.000	12.50	0.25	14.00	5/8"-11UNC	11.135
364TC/365TSC	11.000	12.50	0.25	14.00	5/8"-11UNC	11.625

FRAME SIZE	MOTOR DIMENSIONS		CONDUIT BOX		
	C	O+T	AA	AB	AC
364TC	32.54	21.30	3.58	17.32	12.8
364TSC	30.41	21.30	3.58	17.32	12.8
365TC	33.52	21.30	3.58	17.32	12.8
365TSC	31.39	21.30	3.58	17.32	12.8

FRAME SIZE	SHAFT EXTENSION				KEY SEAT			BEARINGS		MAXIMUM WEIGHT
	AH	N-W	V	U	R	S	ES	LS	OS	
364TC/365TC	5.62	5.88	5.75	2.375	2.021	0.625	4.28	NU215	6312	580 lbs.
364TSC/365TSC	3.50	3.75	3.50	1.875	1.591	0.500	2.03	6312C3	6312C3	610 lbs.

**CERTIFIED DATA**

ALL DATA SUBJECT TO CHANGE WITHOUT NOTICE FOR CONSTRUCTION USE ONLY CERTIFIED DATA

CUSTOMER: \_\_\_\_\_ P.O. NO.: \_\_\_\_\_ TAG NO.: \_\_\_\_\_

MOTOR MODEL NO.: **0506FTSC24A-P** TOSHIBA FILE NO.: \_\_\_\_\_

HP: **50** RPM (SYN.): **1200** VOLTAGE: **575** Hz: **60**

FRAME SIZE: **365TC** LOG NO.: \_\_\_\_\_ LOG REV. LEVEL: \_\_\_\_\_

REMARKS: \_\_\_\_\_

PER: \_\_\_\_\_ ISSUE DATE: \_\_\_\_\_ SUPERSEDES: \_\_\_\_\_

**TOSHIBA/HOUSTON**

**TOTALLY-ENCLOSED  
FAN-COOLED  
C-FACE MOUNTED  
Fr. 364TC-365TC  
Fr. 364TSC-365TSC**

SAS001199

**TOSHIBA INTERNATIONAL CORPORATION**  
**Industrial Division / Houston Motor Plant**

**SQUIRREL CAGE INDUCTION MOTOR  
 PERFORMANCE SPECIFICATIONS**

INDEX	MPCF-1033
SHEET NO.	1 of 1
ISSUED	11/08/96
SUPERSEDES	10/06/95
REVISION	1
WRITTEN BY	R. EVANS
APPROVED BY	<i>Jay Bugbee</i>

Customer Tag:

CUSTOMER:  
 TIC SR No.:  
 Customer PO:

**MOTOR NAMEPLATE DATA**

H.P.: 50	VOLTS: 575	3 Ø / 60	Hz	S. RPM: 1200
FRAME: 365TC	ENCL: TEFC	FLAMPS: 46.40		FLRPM: 1175
FORM: FCKL1	S.F.: 1.15	NEMA DESIGN: B		INSUL CLASS: F
TYPE: TIKK	AMB.: 40	CODE: G		DUTY: CONT.
MODEL No.: 0506FTSC24A-P		kW:		Serial No.:
NOM. EFF.:	MIN. EFF.:	P.F.:91.7		

<b>AMPERAGE</b> Locked Rotor: 288.00	<b>TORQUES</b> FULL LOAD (lb-ft.): 223 LOCKED ROTOR (%): 170 BREAK DOWN (%): 280	<b>** BEARINGS:</b> Drive End: NU215 Opposite Drive End: 6312
---	---	---

<b>EFFICIENCY (%)</b> FULL LOAD: 93.0 3/4 LOAD: 92.0 1/2 LOAD: 91.0	<b>POWER FACTOR (%)</b> FULL LOAD: 87.0 3/4 LOAD: 84.0 1/2 LOAD: 77.0
--	--

ALL CHARACTERISTICS ARE AVERAGE EXPECTED VALUES BASED UPON RATED VOLTAGE, FREQUENCY AND SINEWAVE POWER INPUT.

\* TEMPERATURE RISE WILL BE CONSISTENT WITH INSULATION, AMBIENT AND SERVICE FACTOR AS DEFINED BY NEMA-MG-12.43 OR -20.40.

\*\* BEARINGS ARE THE ONLY RECOMMENDED SPARE PART(S).

**CERTIFIED BY:**  
**DATE:**

**TOSHIBA**

Reliability in Motion

**TOSHIBA INTERNATIONAL CORPORATION**

INDUSTRIAL DIVISION

PO BOX 40906

HOUSTON TX 77240

(713) 466-0277

(800) 231-1412

FAX (713) 466-8773

**SPARE PARTS (RECOMMENDED)**

OTHER THAN THE GREASE USED FOR RE-GREASABLE BEARINGS, **TOSHIBA** ADVISES THAT THERE ARE NO "USE" PARTS. THE ONLY INSURANCE SPARES THAT **TOSHIBA** SUGGESTS FOR THESE SQUIRREL CAGE INDUCTION MOTORS ARE INDUSTRY STANDARD, AND COMMERCIALY AVAILABLE ANTI-FRICTION BEARINGS, AS NOTED BELOW.

MOTOR COMPONENTS (SUCH AS TERMINAL BOXES, FAN COVERS, MACHINED PARTS) ARE AVAILABLE UPON SPECIAL REQUEST. IN THIS CASE, PLEASE ADVISE OUR ORDER ENTRY DEPARTMENT THE MODEL AND SERIAL NUMBERS (FOUND ON THE MOTOR NAMEPLATE) , AND A DESCRIPTION OF THE COMPONENT REQUIRED. THEY WILL THEN FURNISH THE CURRENT PART NUMBER, PRICE AND AVAILABILITY.

(NOTE: OUR INTERNAL PART NUMBERS ARE SUBJECT TO CHANGE WITHOUT NOTICE, AND ARE NOT PUBLISHED).

PLEASE ADVISE IF YOU HAVE ANY QUESTIONS.

CUSTOMER:  
PURCHASE ORDER #  
Customer Tag:

TOSHIBA FILE #  
MODEL # 0506FTSC24A-P  
HP / RPM / ENCL / FRAME: 50 / 1200 / TEFC / 365TC  
DRIVE END BEARING: NU215  
OPPOSITE DRIVE END BEARING: 6312

**Prepared By:**  
**Date:**