

TOSHIBA/HOUSTON

TOTALLY-ENCLOSED FAN-COOLED Fr. 447T/TS-449T/TS  
HORIZONTAL FOOT-MOUNTED

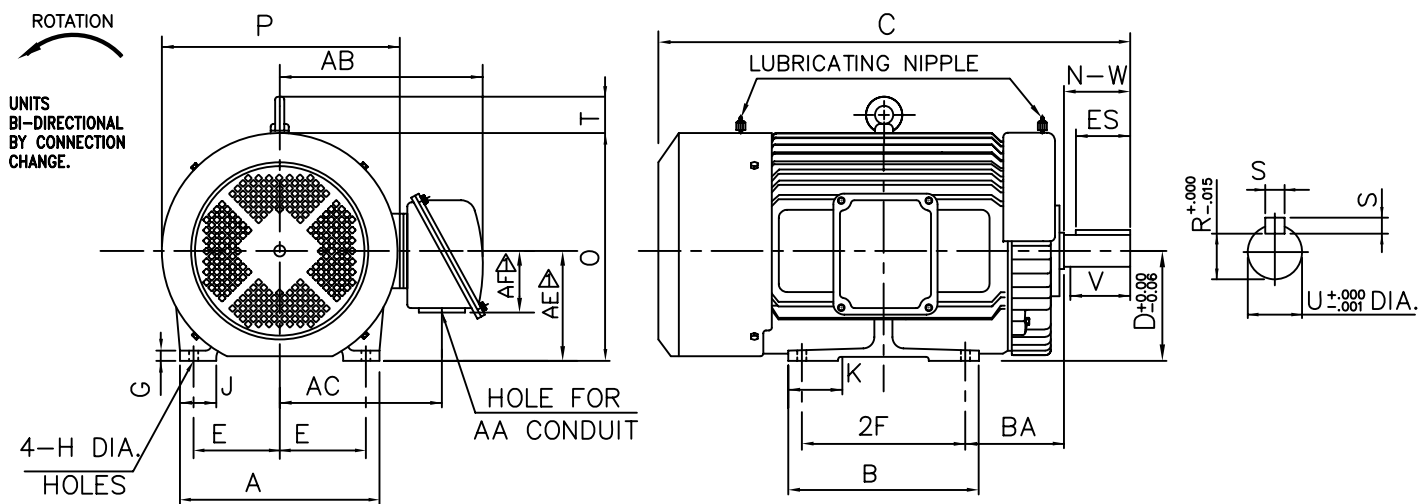

UNITS: INCHES

FRAME SIZE	MOUNTING				CONDUIT BOX						
	E	2F	H	BA	AA	AB	AC	AE	AF	XL	XN
447T/447TS	9.00	20.00	0.81	7.50	NPT3 <sup>1</sup> / <sub>2</sub> "	22.95	17.63	11.00 <sup>A</sup>	9.94 <sup>A</sup>	--	--
449T/449TS	9.00	25.00	0.81	7.50	NPT3 <sup>1</sup> / <sub>2</sub> "	22.95	17.63	11.00 <sup>A</sup>	9.94 <sup>A</sup>	--	--

FRAME SIZE	MOTOR DIMENSIONS									
	A	B	C	D	G	J	K	O	T	P
447T	22.05	22.83 <sup>A</sup>	57.52	11.00	1.18	4.33	5.71	23.50	4.33	26.77
447TS	22.05	22.83 <sup>A</sup>	53.77	11.00	1.18	4.33	5.71	23.50	4.33	26.77
449T	22.05	27.83	57.52	11.00	1.18	4.33	5.71	23.50	4.33	26.77
449TS	22.05	27.83	53.77	11.00	1.18	4.33	5.71	23.50	4.33	26.77

FRAME SIZE	SHAFT EXTENSION			KEY SEAT			BEARINGS		MAXIMUM WEIGHT
	N-W	V	U	R	S	ES	LS	OS	
447T	8.50	8.25	3.375	2.880	0.875	6.91	NU220	6315	2460 lbs.
447TS	4.75	4.50	2.375	2.021	0.625	3.03	6313C3	6313C3	2430 lbs.
449T	8.50	8.25	3.375	2.880	0.875	6.91	NU320	6318	2778 lbs.
449TS	4.75	4.50	2.375	2.021	0.625	3.03	6313C3	6313C3	2750 lbs.

ALL DATA SUBJECT TO CHANGE WITHOUT NOTICE.  
FOR CONSTRUCTION USE ONLY CERTIFIED DATA.

CERTIFIED DATA

NOTES:

- DIMENSION V REPRESENTS LENGTH OF STRAIGHT PART OF SHAFT.
- CONDUIT BOX MAY BE ROTATED IN 90° INCREMENTS AND MAY BE MOUNTED ON OPPOSITE SIDE ON SPECIAL ORDER.
- "T" KEY DIMENSIONS EQUAL S x S x 6.875  
"TS" KEY DIMENSIONS EQUAL S x S x 3.000 (MOTOR SUPPLIED WITH KEY)
- MOTOR WEIGHT SHOWN IS MAXIMUM HORSEPOWER IN FRAME.

CUSTOMER: \_\_\_\_\_ P.O. NO.: \_\_\_\_\_ TAG NO.: \_\_\_\_\_

MOTOR MODEL NO.: **1506FTCC21A-P** TOSHIBA FILE NO.: \_\_\_\_\_

HP: **150** RPM (SYN.): **1200** VOLTAGE: **575** Hz: **60**

FRAME SIZE: **447T** LOG NO.: \_\_\_\_\_ LOG REV. LEVEL: \_\_\_\_\_

REMARKS: \_\_\_\_\_

PER: \_\_\_\_\_ ISSUE DATE: \_\_\_\_\_ SUPERSEDES: \_\_\_\_\_

**TOSHIBA INTERNATIONAL CORPORATION**  
**Industrial Division / Houston Motor Plant**

**SQUIRREL CAGE INDUCTION MOTOR  
 PERFORMANCE SPECIFICATIONS**

INDEX	MPCF-1033
SHEET NO.	1 of 1
ISSUED	11/08/96
SUPERSEDES	10/06/95
REVISION	1
WRITTEN BY	R. EVANS
APPROVED BY	<i>Jay Bugbee</i>

Customer Tag:

CUSTOMER:  
 TIC SR No.:  
 Customer PO:

**MOTOR NAMEPLATE DATA**

H.P.: 150	VOLTS: 575	3 Ø / 60	Hz	S. RPM: 1200
FRAME: 447T	ENCL: TEFC	FLAMPS: 146		FLRPM: 1180
FORM: FBK1	S.F.: 1.15	NEMA DESIGN: C		INSUL CLASS: F
TYPE: TIKK	AMB.: 40C	CODE: G		DUTY: CONT.
MODEL No.: 1506FTCC21A-P		kW: 110		Serial No.:
NOM. EFF.: 95	MIN. EFF.:	P.F.: 82.0		

<b>AMPERAGE</b> Locked Rotor: 983	<b>TORQUES</b> FULL LOAD (lb-ft.): 668.00 LOCKED ROTOR (%): 204 BREAK DOWN (%): 265	<b>** BEARINGS:</b> Drive End: 6315 Opposite Drive End: NU220
--------------------------------------	--	---

<b>EFFICIENCY (%)</b> FULL LOAD: 95.0 3/4 LOAD: 94.0 1/2 LOAD: 93.5	<b>POWER FACTOR (%)</b> FULL LOAD: 82.0 3/4 LOAD: 77.0 1/2 LOAD: 69.0
--	--

ALL CHARACTERISTICS ARE AVERAGE EXPECTED VALUES BASED UPON RATED VOLTAGE, FREQUENCY AND SINEWAVE POWER INPUT.

\* TEMPERATURE RISE WILL BE CONSISTENT WITH INSULATION, AMBIENT AND SERVICE FACTOR AS DEFINED BY NEMA-MG-12.43 OR -20.40.

\*\* BEARINGS ARE THE ONLY RECOMMENDED SPARE PART(S).

**CERTIFIED BY:**  
**DATE:**

**TOSHIBA**

Reliability in Motion

**TOSHIBA INTERNATIONAL CORPORATION**

INDUSTRIAL DIVISION

PO BOX 40906

HOUSTON TX 77240

(713) 466-0277

(800) 231-1412

FAX (713) 466-8773

**SPARE PARTS (RECOMMENDED)**

OTHER THAN THE GREASE USED FOR RE-GREASABLE BEARINGS, **TOSHIBA** ADVISES THAT THERE ARE NO "USE" PARTS. THE ONLY INSURANCE SPARES THAT **TOSHIBA** SUGGESTS FOR THESE SQUIRREL CAGE INDUCTION MOTORS ARE INDUSTRY STANDARD, AND COMMERCIALY AVAILABLE ANTI-FRICTION BEARINGS, AS NOTED BELOW.

MOTOR COMPONENTS (SUCH AS TERMINAL BOXES, FAN COVERS, MACHINED PARTS) ARE AVAILABLE UPON SPECIAL REQUEST. IN THIS CASE, PLEASE ADVISE OUR ORDER ENTRY DEPARTMENT THE MODEL AND SERIAL NUMBERS (FOUND ON THE MOTOR NAMEPLATE) , AND A DESCRIPTION OF THE COMPONENT REQUIRED. THEY WILL THEN FURNISH THE CURRENT PART NUMBER, PRICE AND AVAILABILITY.

(NOTE: OUR INTERNAL PART NUMBERS ARE SUBJECT TO CHANGE WITHOUT NOTICE, AND ARE NOT PUBLISHED).

PLEASE ADVISE IF YOU HAVE ANY QUESTIONS.

CUSTOMER:  
PURCHASE ORDER #  
Customer Tag:

TOSHIBA FILE #  
MODEL # 1506FTCC21A-P  
HP / RPM / ENCL / FRAME: 150 / 1200 / TEFC / 447T  
DRIVE END BEARING: 6315  
OPPOSITE DRIVE END BEARING: NU220

**Prepared By:**  
**Date:**

Three Phase Motor Wiring Diagram
"Across the line" (Full Voltage) Starting

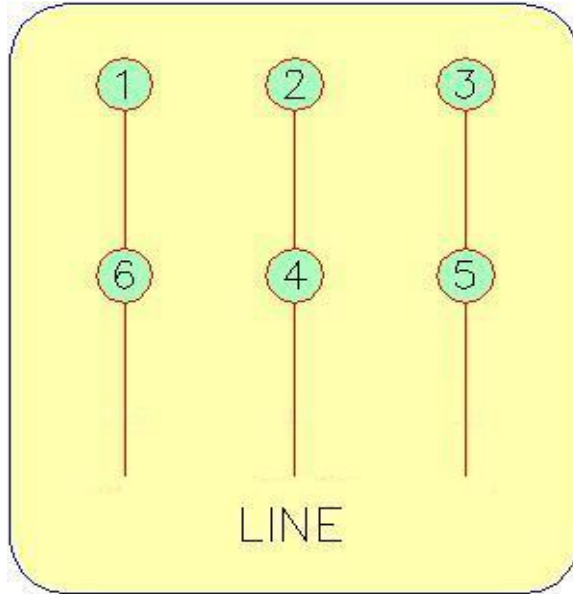

Customer Name:	
PO No.:	
Customer Tag:	
TIC File No.:	
Motor Model No.	1506FTCC21A-P

For Further Information Regarding Toshiba motor starting, maintenance or wiring,  
Please refer to the "Toshiba - A Quality Product for World Energy" Installation and  
Maintenance Manual, or contact the Toshiba Low Voltage Motor Marketing Department.  
(800) 231-1412

Prepared By:   
Date: