

ø3/4"-10 UNC 4 PLACES FOR JACKING BOLTS

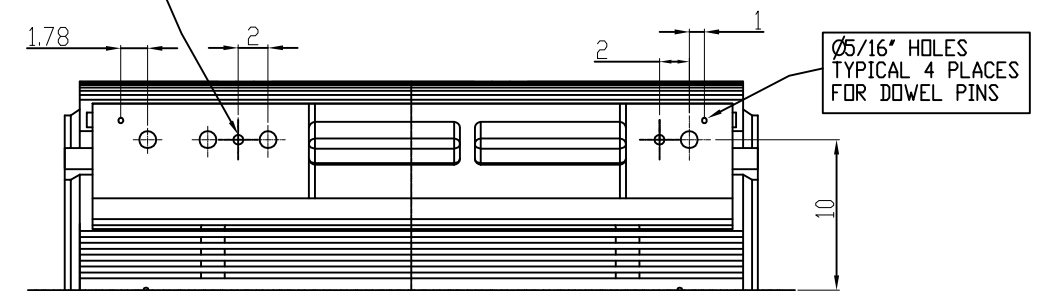

UNITS: INCHES

TECHNICAL INFORMATION

1. BEARING LUBRICATION DE: MOBIL POLYREX EM
ODE: MOBIL POLYREX EM
2. BEARING TYPE DE: 6320C3
ODE: 6320C3 INSULATED
3. WINDING TEMP. DETECTORS
NUMBER AND TYPE: 6xRTD(Pt0°C-100ohm)
LOCATION: IN STATOR SLOT
4. BEARING TEMP. DETECTORS
NUMBER AND TYPE: _____
5. SPACE HEATER 1 PHASE
VOLTS: 120 WATTS: 240
6. ROTATION: CCW VIEWED FROM NON DRIVE END
THIS MOTOR IS BI DIRECTIONAL
7. MOTOR PAINT COLOR: GRAY
8. APPROX. WEIGHT: 5000 Lbs
9. ACCESSORIES:

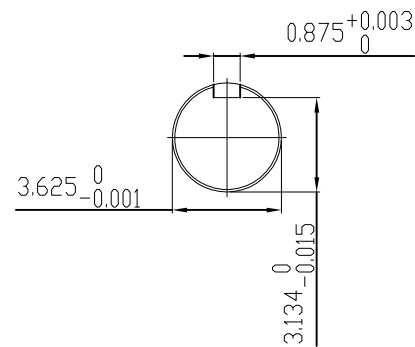

DRAWING LIST

MAIN TERMINAL BOX				
130-7622-55				
AUX TERMINAL BOX FOR				
SPACE HEATER	130-7520-50			
R.T.D.	130-7522-51			
THERMISTOR	N/A			
PRODUCTION #	N/A			

2	GRS FROM SRI, ADD DOWELS JACKING TO INLINE	RWS	1/6/14
1	CHG FAB. FC FOR C.I. FC	JMP	9/24/08
0	FIRST ISSUE	BCS	4/24/07
NO.	REVISION	BY	DATE

MOTOR OUTLINE FOR THREE PHASE INDUCTION MOTOR

CUSTOMER NAME				P.O. NO.	MOTOR TAG NO.	
OUTPUT HP	POLE	VOLTAGE V	FREQUENCY Hz	FULL LOAD SPEED (min ⁻¹)	TOSHIBA MODEL NO.	
TYPE	FORM	INS. CLASS F	RATING CONT.	FRAME 5011US	S.F.	ENCLOSURE TEFC
TOSHIBA INTERNATIONAL CORPORATION HOUSTON, TEXAS U.S.A.						
3rd ANGLE PROJ.	PREPARED BY: B SIDLE	DATE: 4/24/07	CHECKED BY: S Johnson	DATE: 4/26/07	DRAWING NO.: MDSL0071-15	REV. 2

TYPICAL MOTOR PERFORMANCE DATA

Model: 3006FTAL11E-C

HP	kW	Pole	FL RPM	Frame	Voltage	Hz	Phase	FL Amps
300	224	6	1181	5011US	4000	60	3	45
Enclosure	IP	Ins. Class	S.F.	Duty	NEMA Nom. Eff.	NEMA Design	kVA Code	Ambient (°C)
TEFC	44	F	1.15	CONT	94.5	A	G	40 C

Load	HP	kW	Amperes	Efficiency (%)	Power Factor (%)
Full Load	300	223.7	45.0	94.5	76.2
¾ Load	225.00	167.8	36.9	93.9	69.9
½ Load	150.00	111.9	30.2	92.1	58.0
¼ Load	75.00	55.9	22.7	86.9	40.9
No Load			20.0		3.5
Locked Rotor			268.00		32.4

Torque				Rotor wk ²
Full Load (lb-ft)	Locked Rotor (% FLT)	Pull Up (% FLT)	Break Down (% FLT)	Inertia (lb-ft ²)
1334	215	175	270	184.58

Safe Stall Time(s)		Sound Pressure dB(A) @ 1M	Bearings*		Approx. Motor Weight (lbs)
Cold	Hot		DE	NDE	
12.5	6.9	-	6320C3	6320C3 INS	

*Bearings are the only recommended spare part(s).

Motor Options:
Product Family:TEFC
Mounting:Footed,Shaft:US Shaft

Customer	
Customer PO	
Sales Order	
Project #	

Tag:

All characteristics are average expected values.

TOSHIBA INTERNATIONAL CORPORATION · HOUSTON, TEXAS U.S.A.

Engineering	bammen	Doc. Written By	D. Suarez	Doc.# / Rev	MPCF-1119 / 0
Engr. Date	7/8/2014	Doc. Approved By	M. Campbell	Doc. Issued	6/8/2011

SPEED TORQUE/CURRENT CURVE

Model: 3006FTAL11E-C

HP	kW	Pole	FL RPM	Frame	Voltage	Hz	Phase	FL Amps
300	224	6	1181	5011US	4000	60	3	45
Enclosure	IP	Ins. Class	S.F.	Duty	NEMA Nom. Eff.	NEMA Design	kVA Code	Ambient (°C)
TEFC	44	F	1.15	CONT	94.5	A	G	40 C
Locked Rotor Amps	Rotor wk ² Inertia (lb-ft ²)	Torque						Break Down (%)
		Full Load (lb-ft)	Locked Rotor (%)	Pull Up (%)				
268.00	184.58	1334	215	175			270	

Design Values

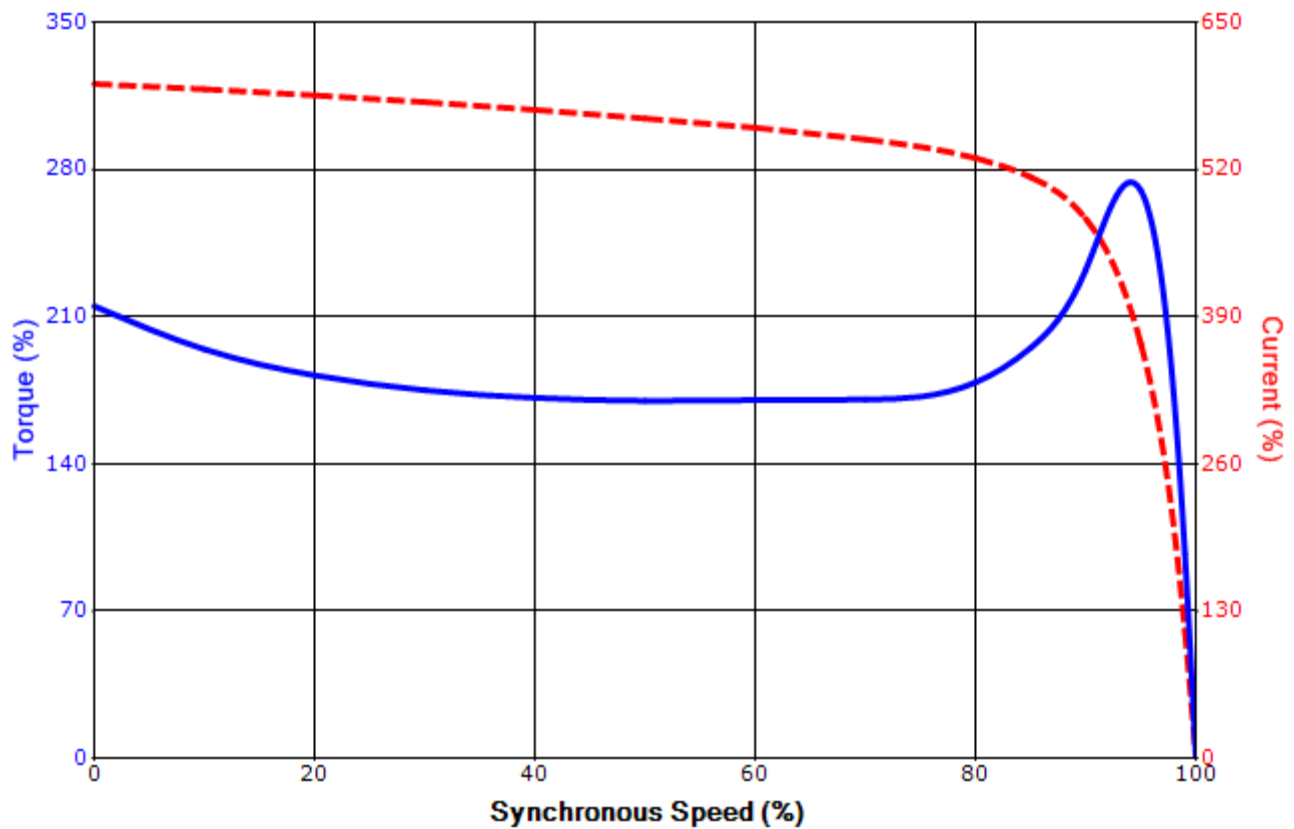

Customer		wk ² Load Inertia (lb-ft ²)	-
Customer PO		Load Type	-
Sales Order		Voltage (%)	100
Project #		Accel. Time	-

Tag:

All characteristics are average expected values.

TOSHIBA INTERNATIONAL CORPORATION · HOUSTON, TEXAS U.S.A.

Engineering	bmammen	Doc. Written By	D. Suarez	Doc.# / Rev	MPCF-1121 / 0
Engr. Date	7/8/2014	Doc. Approved By	M. Campbell	Doc. Issued	6/8/2011

Motor Connection Diagrams
6 Leads

Across the Line Starting / Run - Delta:



Alternate Starting Connection - Wye:



Switch L1 and L2 to reverse rotation