

Ø3/4"-10 UNC 4 PLACES FOR JACKING BOLTS

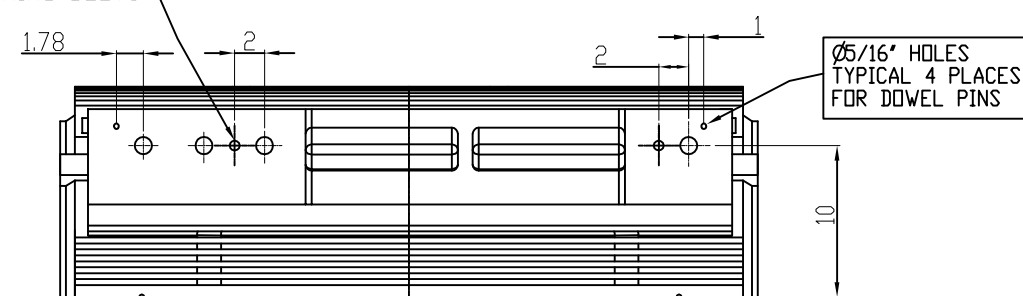

UNITS: INCHES

TECHNICAL INFORMATION

1. BEARING LUBRICATION DE: MOBIL POLYREX EM
ODE: MOBIL POLYREX EM
2. BEARING TYPE DE: 6313C3
ODE: 6313C3 INSULATED
3. WINDING TEMP. DETECTORS
NUMBER AND TYPE: 6xRTD(Pt0°C-100ohm)
LOCATION: IN STATOR SLOT
4. BEARING TEMP. DETECTORS
NUMBER AND TYPE: _____
5. SPACE HEATER 1 PHASE
VOLTS: 120 WATTS: 240
6. ROTATION: CCW VIEWED FROM NON DRIVE END
THIS MOTOR IS UNI DIRECTIONAL
7. MOTOR PAINT COLOR: GRAY
8. APPROX. WEIGHT: 5000 Lbs
9. ACCESSORIES:

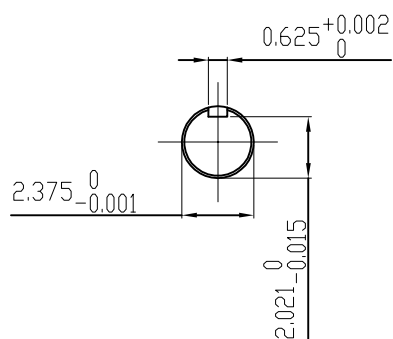

DRAWING LIST

MAIN TERMINAL BOX 130-7622-55					
AUX TERMINAL BOX FOR					
SPACE HEATER	130-7520-50	2	GRS FROM SRI, ADD DOWELS JACKING TO INLINE	RWS	1/6/13
R.T.D.	130-7522-51	1	CHG FAB. FC FOR C.I. FC	JMP	9/24/08
THERMISTOR	N/A				
		0	FIRST ISSUE	BCS	4/24/07
PRODUCTION #	N/A	NO.	REVISION	BY	DATE

MOTOR OUTLINE FOR THREE PHASE INDUCTION MOTOR

CUSTOMER NAME				P.O. NO.	MOTOR TAG NO.	
OUTPUT HP	POLE	VOLTAGE V	FREQUENCY Hz	FULL LOAD SPEED (min ⁻¹)	TOSHIBA MODEL NO.	
TYPE	FORM	INS. CLASS F	RATING CONT.	FRAME 5011USS	S.F.	ENCLOSURE TEFC
TOSHIBA INTERNATIONAL CORPORATION HOUSTON, TEXAS U.S.A.						
3rd ANGLE PROJ.	PREPARED BY: B SIDLE	DATE: 4/24/07	CHECKED BY: S Johnson	DATE: 4/26/07	DRAWING NO.: MDSL0071-14	REV. 2

TYPICAL MOTOR PERFORMANCE DATA

Model: 4003FTAL11F-C

HP	kW	Pole	FL RPM	Frame	Voltage	Hz	Phase	FL Amps
400	298	2	3575	5811USS	4000	60	3	50
Enclosure	IP	Ins. Class	S.F.	Duty	NEMA Nom. Eff.	NEMA Design	kVA Code	Ambient (°C)
TEFC	44	F	1.15	CONT	93.9	B	F	40 C

Load	HP	kW	Amperes	Efficiency (%)	Power Factor (%)
Full Load	400	298.3	49.6	93.9	92.3
¾ Load	300.00	223.7	38.1	92.9	91.2
½ Load	200.00	149.1	27.0	90.6	87.7
¼ Load	100.00	74.6	17.1	83.9	74.6
No Load			9.9		13.0
Locked Rotor			313.30		18.5

Torque				Rotor wk² Inertia (lb-ft²)
Full Load (lb-ft)	Locked Rotor (% FLT)	Pull Up (% FLT)	Break Down (% FLT)	
588	95	100	275	142.08

Safe Stall Time(s)		Sound Pressure dB(A) @ 1M	Bearings*		Approx. Motor Weight (lbs)
Cold	Hot		DE	NDE	
43.1	23.9	-	6313C3	6313 INS	

*Bearings are the only recommended spare part(s).

Motor Options:
Product Family:TEFC
Mounting:Footed,Shaft:USS Shaft

Customer	
Customer PO	
Sales Order	
Project #	

Tag:

All characteristics are average expected values.

TOSHIBA INTERNATIONAL CORPORATION · HOUSTON, TEXAS U.S.A.

Engineering	bmmamen	Doc. Written By	D. Suarez	Doc.# / Rev	MPCF-1119 / 0
Engr. Date	7/9/2014	Doc. Approved By	M. Campbell	Doc. Issued	6/8/2011

Issued Date	4/23/2015	Transmit #	
Issued By	dschoeck	Issued Rev	

SPEED TORQUE/CURRENT CURVE

Model: 4003FTAL11F-C

HP	kW	Pole	FL RPM	Frame	Voltage	Hz	Phase	FL Amps
400	298	2	3575	5811USS	4000	60	3	50
Enclosure	IP	Ins. Class	S.F.	Duty	NEMA Nom. Eff.	NEMA Design	kVA Code	Ambient (°C)
TEFC	44	F	1.15	CONT	93.9	B	F	40 C
Locked Rotor Amps	Rotor wk ² Inertia (lb-ft ²)	Torque						Break Down (%)
		Full Load (lb-ft)	Locked Rotor (%)	Pull Up (%)				
313.30	142.08	588	95	100			275	

Design Values

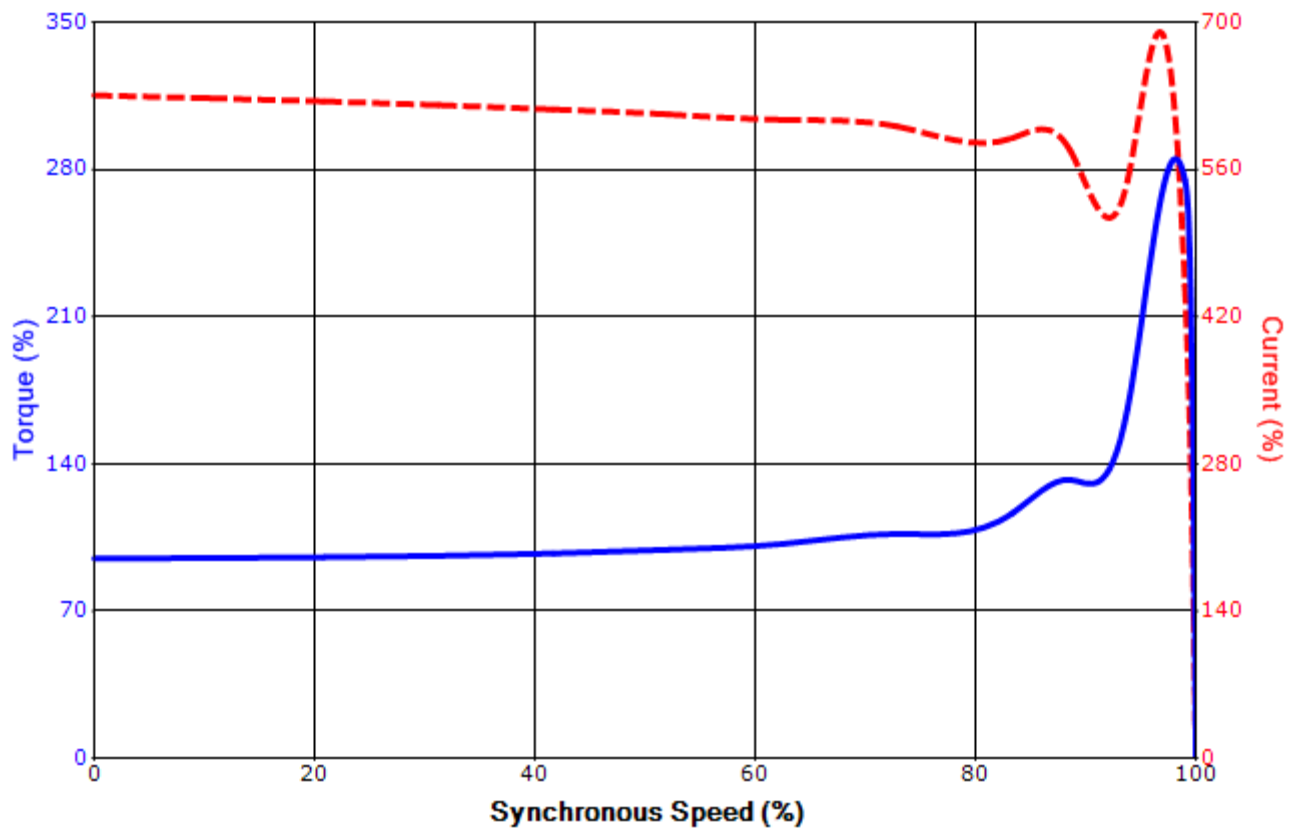

Customer		wk ² Load Inertia (lb-ft ²)	-
Customer PO		Load Type	-
Sales Order		Voltage (%)	100
Project #		Accel. Time	-

Tag:

All characteristics are average expected values.

TOSHIBA INTERNATIONAL CORPORATION · HOUSTON, TEXAS U.S.A.

Engineering	bmammen	Doc. Written By	D. Suarez	Doc.# / Rev	MPCF-1121 / 0
Engr. Date	7/9/2014	Doc. Approved By	M. Campbell	Doc. Issued	6/8/2011

Motor Connection Diagrams
6 Leads

Across the Line Starting / Run - Delta:



Alternate Starting Connection - Wye:



Switch L1 and L2 to reverse rotation