

TECHNICAL INFORMATION

1. BEARING LUBRICATION DE: MOBIL POLYREX EM
ODE: MOBIL POLYREX EM
2. BEARING TYPE DE: 6321C3
ODE: 6321C3 (INSULATED)
3. WINDING TEMP. DETECTORS
NUMBER AND TYPE: 6xRTD(Pt0°C-100ohm)
LOCATION: IN STATOR SLOT
4. BEARING TEMP. DETECTORS
NUMBER AND TYPE: N/A
5. SPACE HEATER 1 PHASE
VOLTS: 120 WATTS: 400
6. ROTATION: CCW VIEWED FROM NON DRIVE END
THIS MOTOR IS BI DIRECTIONAL
7. MOTOR PAINT COLOR: GRAY
8. APPROX. WEIGHT: 5000 Lbs.
9. ACCESORIES:

DRAWING LIST					
MAIN TERMINAL BOX 130-7622-55					
AUX TERMINAL BOX FOR SPACE HEATER 130-7520-50 R.T.D. 130-7522-51 THERMISTOR -					
PRODUCTION #	-	1	GRS FROM SRI	RWS	1/2/14
		0	FIRST ISSUE	MH	012904
UNITS:	INCHES	NO.	REVISION	BY	DATE

MOTOR OUTLINE FOR THREE PHASE INDUCTION MOTOR

CUSTOMER NAME				P.O. NO.	MOTOR TAG NO.	
OUTPUT HP	POLE	VOLTAGE V	FREQUENCY Hz	FULL LOAD SPEED (min ⁻¹)	TOSHIBA MODEL NO.	
TYPE	FORM	INS. CLASS F	RATING CONT.	FRAME 5011/12US	S.F.	ENCLOSURE WP-II
TOSHIBA INTERNATIONAL CORPORATION HOUSTON, TEXAS U.S.A.						
3rd ANGLE PROJ.	PREPARED BY: M.HO	DATE: 012904	CHECKED BY: D. HENSLEY	DATE: 012904	DRAWING NO.: MDSL0087-06	REV. 1

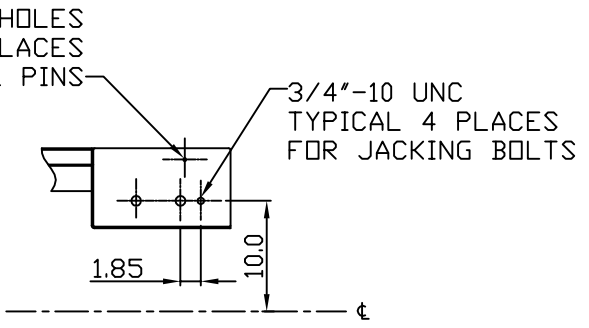

TYPICAL MOTOR PERFORMANCE DATA

Model: 4006WTAK11E-C

HP	kW	Pole	FL RPM	Frame	Voltage	Hz	Phase	FL Amps
400	298	6	1184	5012US	4000	60	3	60
Enclosure	IP	Ins. Class	S.F.	Duty	NEMA Nom. Eff.	NEMA Design	kVA Code	Ambient (°C)
WP-II	24	F	1.15	CONT	94	-	G	40 C

Load	HP	kW	Amperes	Efficiency (%)	Power Factor (%)
Full Load	400	298.3	59.0	94.0	77.5
¾ Load	300.00	223.7	46.4	94.0	73.9
½ Load	200.00	149.1	35.3	93.1	65.5
¼ Load	100.00	74.6	26.8	89.6	44.8
No Load			28.5		2.2
Locked Rotor			350.70		28.0

Torque				Rotor wk ²
Full Load (lb-ft)	Locked Rotor (% FLT)	Pull Up (% FLT)	Break Down (% FLT)	Inertia (lb-ft ²)
1774	175	200	340	185.18

Safe Stall Time(s)		Sound Pressure dB(A) @ 1M	Bearings*		Approx. Motor Weight (lbs)
Cold	Hot		DE	NDE	
28	13.2	-	6321C3	6321C3 INS	

*Bearings are the only recommended spare part(s).

Motor Options:
Product Family:WP-II
Mounting:Footed,Shaft:US Shaft

Customer	
Customer PO	
Sales Order	
Project #	

Tag:

All characteristics are average expected values.

TOSHIBA INTERNATIONAL CORPORATION · HOUSTON, TEXAS U.S.A.

Engineering	bmmamen	Doc. Written By	D. Suarez	Doc.# / Rev	MPCF-1119 / 0
Engr. Date	7/14/2014	Doc. Approved By	M. Campbell	Doc. Issued	6/8/2011

SPEED TORQUE/CURRENT CURVE

Model: 4006WTAK11E-C

HP	kW	Pole	FL RPM	Frame	Voltage	Hz	Phase	FL Amps
400	298	6	1184	5012US	4000	60	3	60
Enclosure	IP	Ins. Class	S.F.	Duty	NEMA Nom. Eff.	NEMA Design	kVA Code	Ambient (°C)
WP-II	24	F	1.15	CONT	94	-	G	40 C
Locked Rotor Amps	Rotor wk ² Inertia (lb-ft ²)	Torque						Break Down (%)
		Full Load (lb-ft)	Locked Rotor (%)	Pull Up (%)				
350.70	185.18	1774	175	200			340	

Design Values

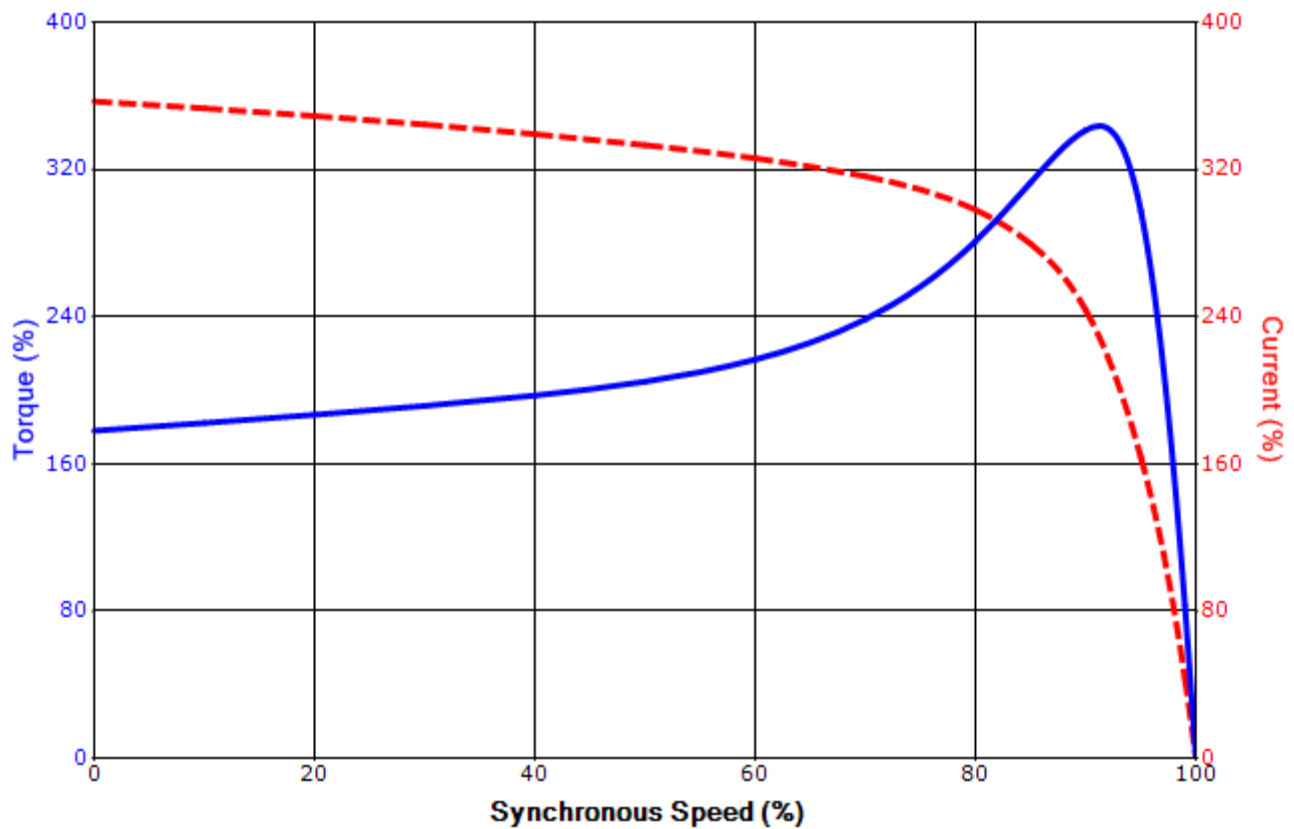

Customer		wk ² Load Inertia (lb-ft ²)	-
Customer PO		Load Type	-
Sales Order		Voltage (%)	100
Project #		Accel. Time	-

Tag:

All characteristics are average expected values.

TOSHIBA INTERNATIONAL CORPORATION · HOUSTON, TEXAS U.S.A.

Engineering	bmammen	Doc. Written By	D. Suarez	Doc.# / Rev	MPCF-1121 / 0
Engr. Date	7/14/2014	Doc. Approved By	M. Campbell	Doc. Issued	6/8/2011