

TECHNICAL INFORMATION

1. BEARING LUBRICATION DE: MOBIL POLYREX EM
ODE: MOBIL POLYREX EM
2. BEARING TYPE DE: 6321C3
ODE: 6321C3 (INSULATED)
3. WINDING TEMP. DETECTORS
NUMBER AND TYPE: 6xRTD(Pt0°C-100ohm)
LOCATION: IN STATOR SLOT
4. BEARING TEMP. DETECTORS
NUMBER AND TYPE: N/A
5. SPACE HEATER 1 PHASE
VOLTS: 120 WATTS: 400
6. ROTATION: CCW VIEWED FROM NON DRIVE END
THIS MOTOR IS BI DIRECTIONAL
7. MOTOR PAINT COLOR: GRAY
8. APPROX. WEIGHT: 5000 Lbs.
9. ACCESORIES:

DRAWING LIST		NO.	REVISION	BY	DATE
MAIN TERMINAL BOX 130-7622-55					
AUX TERMINAL BOX FOR SPACE HEATER 130-7520-50 R.T.D. 130-7522-51 THERMISTOR -					
PRODUCTION #	-	0	FIRST ISSUE	MH	012904
UNITS:	INCHES				

MOTOR OUTLINE FOR THREE PHASE INDUCTION MOTOR									
CUSTOMER NAME				P.O. NO.		MOTOR TAG NO.			
OUTPUT HP	POLE	VOLTAGE V	FREQUENCY Hz	FULL LOAD SPEED (min ⁻¹)		TOSHIBA MODEL NO.			
TYPE	FORM	INS. CLASS F	RATING CONT.	FRAME 5011/12US		S.F.	ENCLOSURE WP-1		
TOSHIBA INTERNATIONAL CORPORATION HOUSTON, TEXAS U.S.A.									
3rd ANGLE PROJ.	PREPARED BY: M.HO	DATE: 012904	CHECKED BY: D. HENSLEY	DATE: 012904	DRAWING NO.: MDSL0086-06	REV. 1			

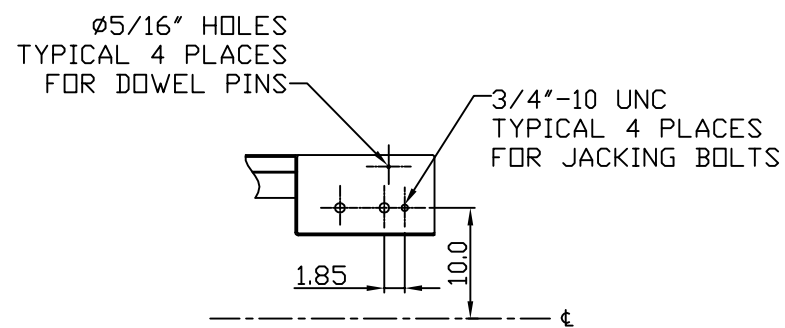

TYPICAL MOTOR PERFORMANCE DATA

Model: 5006WPAK11E-C

HP	kW	Pole	FL RPM	Frame	Voltage	Hz	Phase	FL Amps
500	373	6	1179	5012US	4000	60	3	74
Enclosure	IP	Ins. Class	S.F.	Duty	NEMA Nom. Eff.	NEMA Design	kVA Code	Ambient (°C)
WP-I	23	F	1.15	CONT	93.6	-	J	40 C

Load	HP	kW	Amperes	Efficiency (%)	Power Factor (%)
Full Load	500	372.9	73.6	93.6	78.1
¾ Load	375.00	279.6	59.4	93.4	72.7
½ Load	250.00	186.4	47.3	92.4	61.5
¼ Load	125.00	93.2	38.6	88.5	39.4
No Load			31.2		3.0
Locked Rotor			516.50		27.6

Torque				Rotor wk ²
Full Load (lb-ft)	Locked Rotor (% FLT)	Pull Up (% FLT)	Break Down (% FLT)	Inertia (lb-ft ²)
2227	175	105	310	218.85

Safe Stall Time(s)		Sound Pressure dB(A) @ 1M	Bearings*		Approx. Motor Weight (lbs)
Cold	Hot		DE	NDE	
21.3	12.3	-	6321C3	6321C3 INS	

*Bearings are the only recommended spare part(s).

Motor Options:
Product Family:ODP & WP-I
Mounting:Footed,Shaft:US Shaft

Customer	
Customer PO	
Sales Order	
Project #	

Tag:

All characteristics are average expected values.

TOSHIBA INTERNATIONAL CORPORATION · HOUSTON, TEXAS U.S.A.

Engineering	bammen	Doc. Written By	D. Suarez	Doc.# / Rev	MPCF-1119 / 0
Engr. Date	8/18/2014	Doc. Approved By	M. Campbell	Doc. Issued	6/8/2011

Issued Date	4/23/2015	Transmit #	
Issued By	dschoeck	Issued Rev	

SPEED TORQUE/CURRENT CURVE

Model: 5006WPAK11E-C

HP	kW	Pole	FL RPM	Frame	Voltage	Hz	Phase	FL Amps
500	373	6	1179	5012US	4000	60	3	74
Enclosure	IP	Ins. Class	S.F.	Duty	NEMA Nom. Eff.	NEMA Design	kVA Code	Ambient (°C)
WP-I	23	F	1.15	CONT	93.6	-	J	40 C
Locked Rotor Amps	Rotor wk ² Inertia (lb-ft ²)	Torque						Break Down (%)
		Full Load (lb-ft)	Locked Rotor (%)	Pull Up (%)				
516.50	218.85	2227	175	105			310	

Design Values

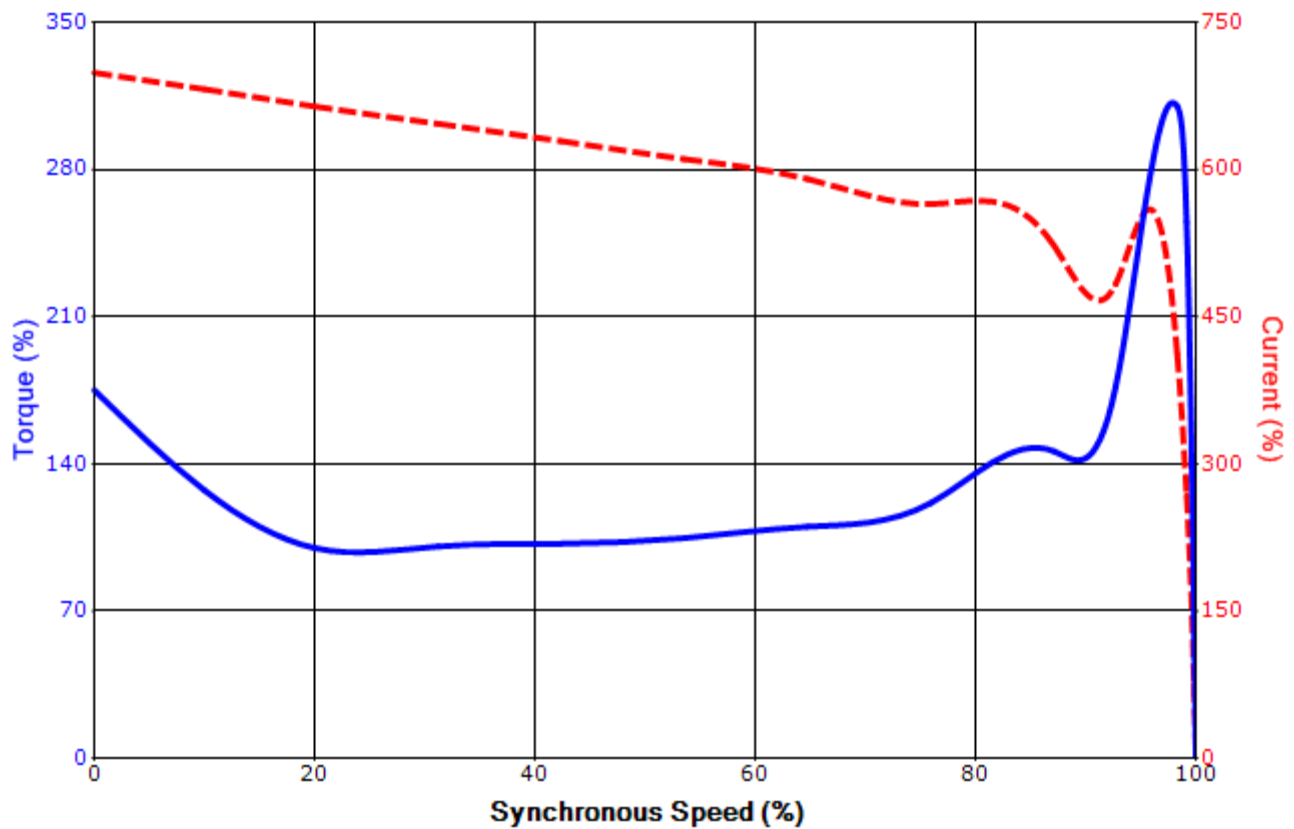

Customer		wk ² Load Inertia (lb-ft ²)	-
Customer PO		Load Type	-
Sales Order		Voltage (%)	100
Project #		Accel. Time	-

Tag:

All characteristics are average expected values.

TOSHIBA INTERNATIONAL CORPORATION · HOUSTON, TEXAS U.S.A.

Engineering	bmammen	Doc. Written By	D. Suarez	Doc.# / Rev	MPCF-1121 / 0
Engr. Date	8/18/2014	Doc. Approved By	M. Campbell	Doc. Issued	6/8/2011

Motor Connection Diagrams
6 Leads

Across-the-Line Starting / Running Connections

Low Voltage – Delta



High Voltage – Wye

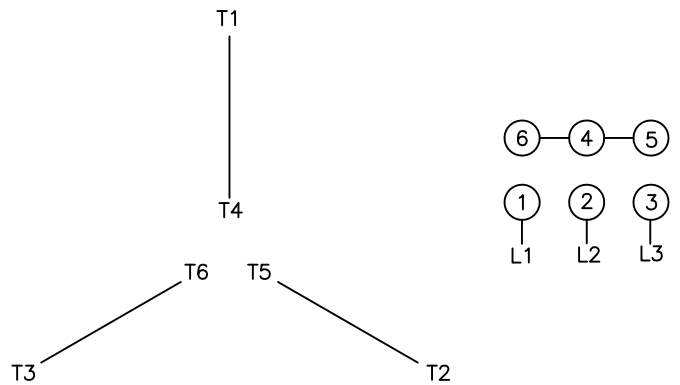

Switch L1 and L2 to reverse rotation