

DUTY MASTER ALTERNATING CURRENT MOTORS

SQUIRREL-CAGE INDUCTION

ENCLOSURE: TOTALLY ENCLOSED
MOUNTING: FOOT

FRAME G447TS ABOVE NEMA RATINGS
INCLUDES 445TS FRAME MOUNTING HOLES

COOLING: FAN COOLED
841XL ENCLOSURE ENHANCEMENT

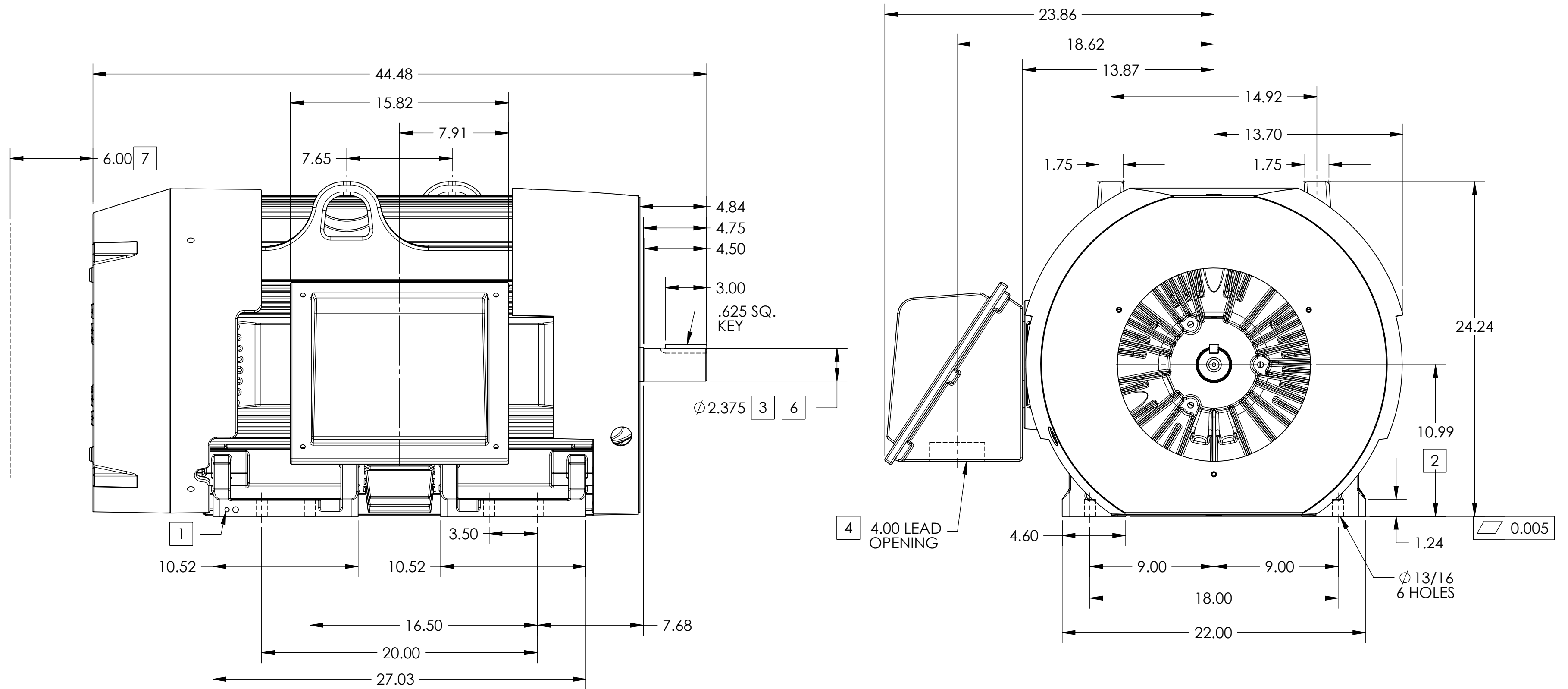

1. GROUND HOLES QTY 1 1/2-13 TAP; QTY 1 3/8-16 TAP
2. VARIES +.00,-.06
3. VARIES +.000,-.001
4. ON STANDARD MOTORS THIS IS CONDUIT SIZE. ON XT AND CORROSION PROOF MOTOR THIS IS PIPE TAP.
5. MOTOR WEIGHTS MAY VARY BY 15% DEPENDING ON RATING.
6. SHAFT TIR = 0.0015 IN FOR BALL BEARING MOTORS AND 0.002 IN FOR ROLLER BEARING CONSTRUCTION
7. OBSTRUCTION MUST NOT ENCROACH ON AIR INLET

5 WEIGHT (LBS): 2480

DRIVE END AIR DEFLECTOR IS ONLY INCLUDED WHEN NECESSARY.

DIMENSIONS ARE IN INCHES; SEE SHEET 2 FOR DIMENSIONS IN MILLIMETERS

CUSTOMER IS RESPONSIBLE FOR DETERMINING THAT MOTOR PERFORMANCE IS SUITABLE IN THE APPLICATION.

CONDUIT BOX LOCATED ON OPPOSITE SIDE WHEN F-2.
IF MOUNTING CLEARANCE DETAILS ARE REQUIRED, CONSULT FACTORY.
MAXIMUM PERMISSIBLE SHAFT RUNOUT WHEN MEASURED AT END OF STANDARD SHAFT EXTENSION IS .003" T.I.R. TO 5 INCH DIA.

REV. DESC: CHANGING ENCLOSURE TO "TOTALLY ENCLOSED" WAS "UL..."			
REV: A	VERSION: 01	REVISED: 09:37:02 02/18/2013	TDR: 000000786306
MODEL NO. 617427-065		REF:	
BY: MGHWCG	Material:	C	

BALDOR

G447TS/445TS STD - FOOTED - SIDE/CENTER C/B - 841XL

DUTY MASTER ALTERNATING CURRENT MOTORS

SQUIRREL-CAGE INDUCTION

ENCLOSURE: TOTALLY ENCLOSED
MOUNTING: FOOT

FRAME G447TS ABOVE NEMA RATINGS
INCLUDES 445TS FRAME MOUNTING HOLES

COOLING: FAN COOLED
841XL ENCLOSURE ENHANCEMENT

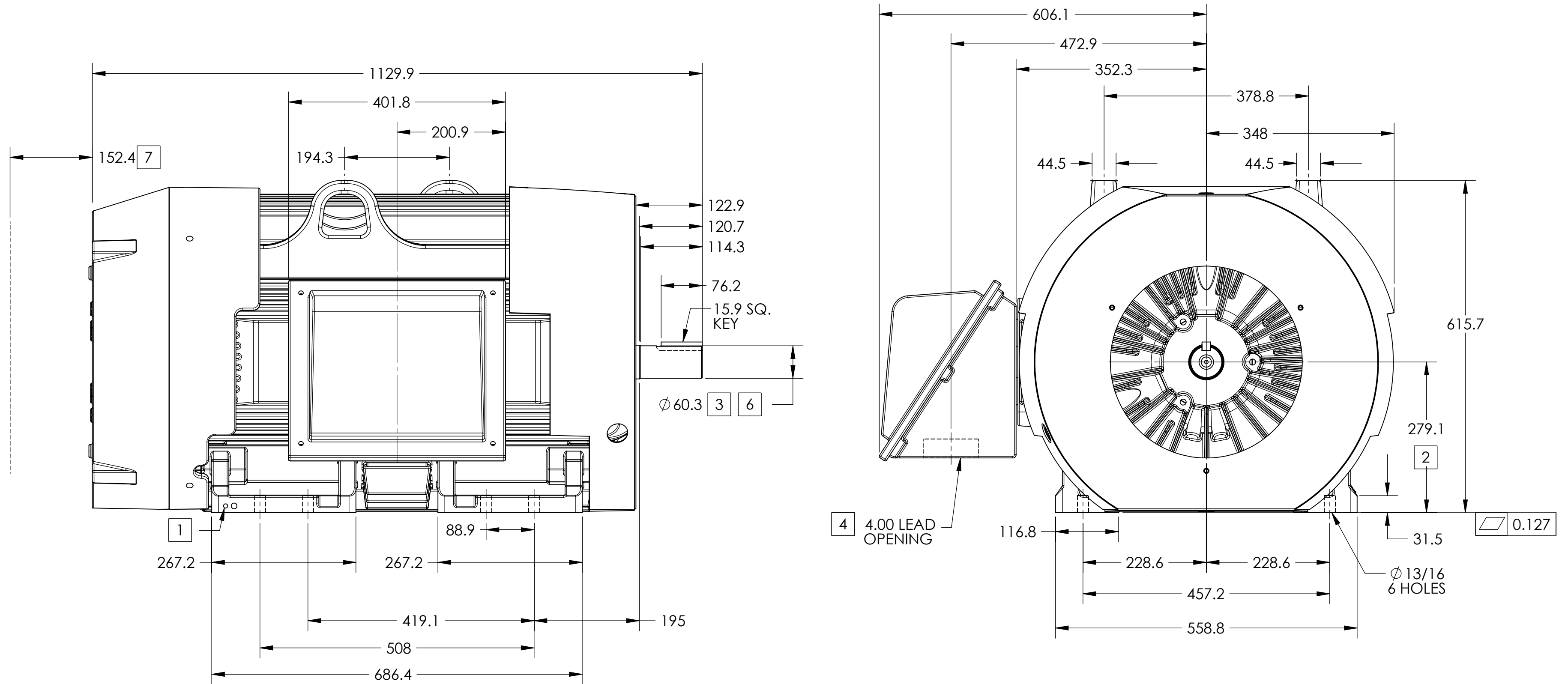

1. GROUND HOLES QTY 1 1/2-13 TAP; QTY 1 3/8-16 TAP
2. VARIES +.00,-.06
3. VARIES +.000,-.001
4. ON STANDARD MOTORS THIS IS CONDUIT SIZE. ON XT AND CORROSION PROOF MOTOR THIS IS PIPE TAP.
5. MOTOR WEIGHTS MAY VARY BY 15% DEPENDING ON RATING.
6. SHAFT TIR = 0.038MM FOR BALL BEARING MOTORS AND 0.051 MM FOR ROLLER BEARING CONSTRUCTION
7. OBSTRUCTION MUST NOT ENCROACH ON AIR INLET

CONDUIT BOX LOCATED ON OPPOSITE SIDE WHEN F-2.
IF MOUNTING CLEARANCE DETAILS ARE REQUIRED, CONSULT FACTORY.
MAXIMUM PERMISSIBLE SHAFT RUNOUT WHEN MEASURED AT END OF STANDARD SHAFT EXTENSION IS .08 MM T.I.R. TO 127 MM DIA.

5 WEIGHT (KGS): 1125

DRIVE END AIR DEFLECTOR IS ONLY INCLUDED WHEN NECESSARY.

DIMENSIONS ARE IN MILLIMETERS; SEE SHEET 1 FOR DIMENSIONS IN INCHES

CUSTOMER IS RESPONSIBLE FOR DETERMINING THAT MOTOR PERFORMANCE IS SUITABLE IN THE APPLICATION.

REV. DESC: CHANGING ENCLOSURE TO "TOTALLY ENCLOSED" WAS "UL..."			
REV: A	VERSION: 01	REVISED: 09:37:02 02/18/2013	TDR: 000000786306
MODEL NO. 617427-065		REF:	
BY: MGHWCG	Material:	C	

BALDOR

G447TS/445TS STD - FOOTED - SIDE/CENTER C/B - 841XL