

DUTY MASTER ALTERNATING CURRENT MOTORS

SQUIRREL-CAGE INDUCTION

ENCLOSURE: TOTALLY ENCLOSED

FRAME G405T ABOVE NEMA RATINGS

COOLING: FAN COOLED

MOUNTING: FOOT

INCLUDES 404T FRAME MOUNTING HOLES

STANDARD INDUSTRIAL ENCLOSURE

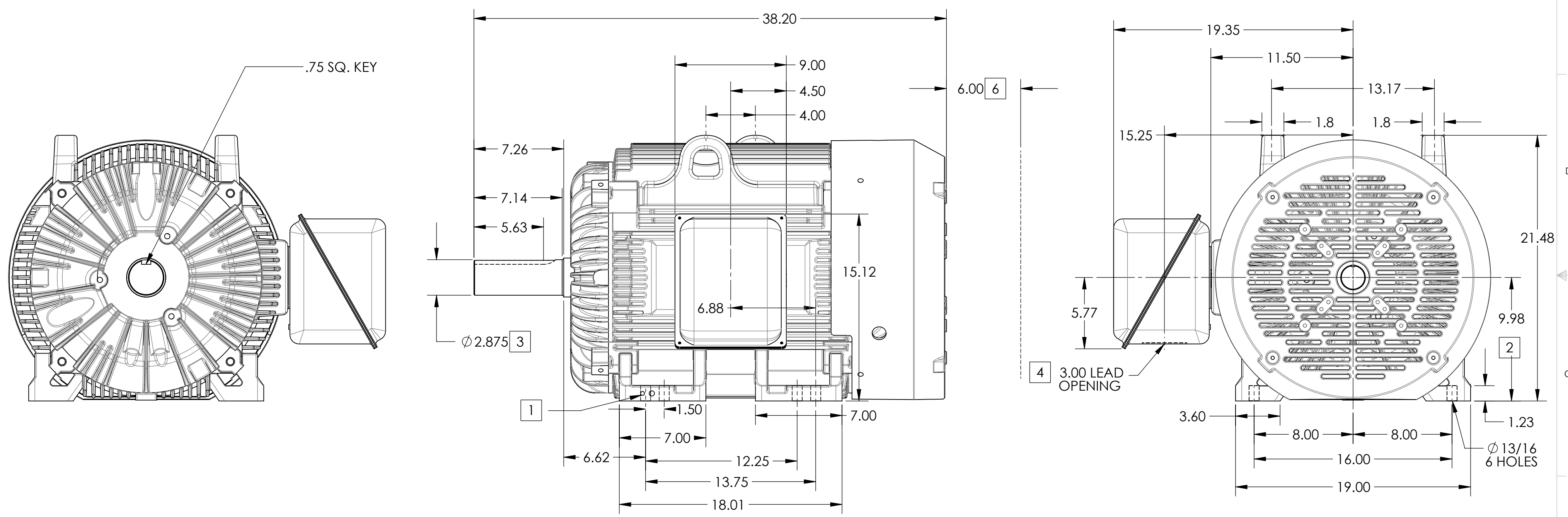

1. GROUND HOLES QTY 1 1/2-13 TAP; QTY 1 3/8-16 TAP
2. VARIES +.00,-.06
3. VARIES +.000,-.001
4. ON STANDARD MOTORS THIS IS CONDUIT SIZE. ON XT AND CORROSION PROOF MOTOR THIS IS PIPE TAP.
5. MOTOR WEIGHTS MAY VARY BY 15% DEPENDING ON RATING.
6. OBSTRUCTION MUST NOT ENCROACH ON AIR INLET

5 WEIGHT (LBS): 1350

CONDUIT BOX LOCATED ON OPPOSITE SIDE WHEN F-1.
 IF MOUNTING CLEARANCE DETAILS ARE REQUIRED, CONSULT FACTORY.
 MAXIMUM PERMISSIBLE SHAFT RUNOUT WHEN MEASURED AT END OF
 STANDARD SHAFT EXTENSION IS .003" T.I.R. TO 5 INCH DIA.

DIMENSIONS ARE IN INCHES; SEE SHEET 2 FOR DIMENSIONS IN MILLIMETERS

CUSTOMER IS RESPONSIBLE FOR DETERMINING THAT MOTOR PERFORMANCE IS SUITABLE IN THE APPLICATION.

REV. DESC: CHANGE BA FROM 6.76 TO 6.62			
REV: A	VERSION: 01	REVISED: 11:53:40 04/14/2014	TDR: 000000848770
MODEL NO. 617429-011		REF:	
BY: MGHJMZ2	Material:		

DUTY MASTER ALTERNATING CURRENT MOTORS

SQUIRREL-CAGE INDUCTION

ENCLOSURE: TOTALLY ENCLOSED
MOUNTING: FOOT

FRAME G405T ABOVE NEMA RATINGS
INCLUDES 404T FRAME MOUNTING HOLES

COOLING: FAN COOLED
STANDARD INDUSTRIAL ENCLOSURE

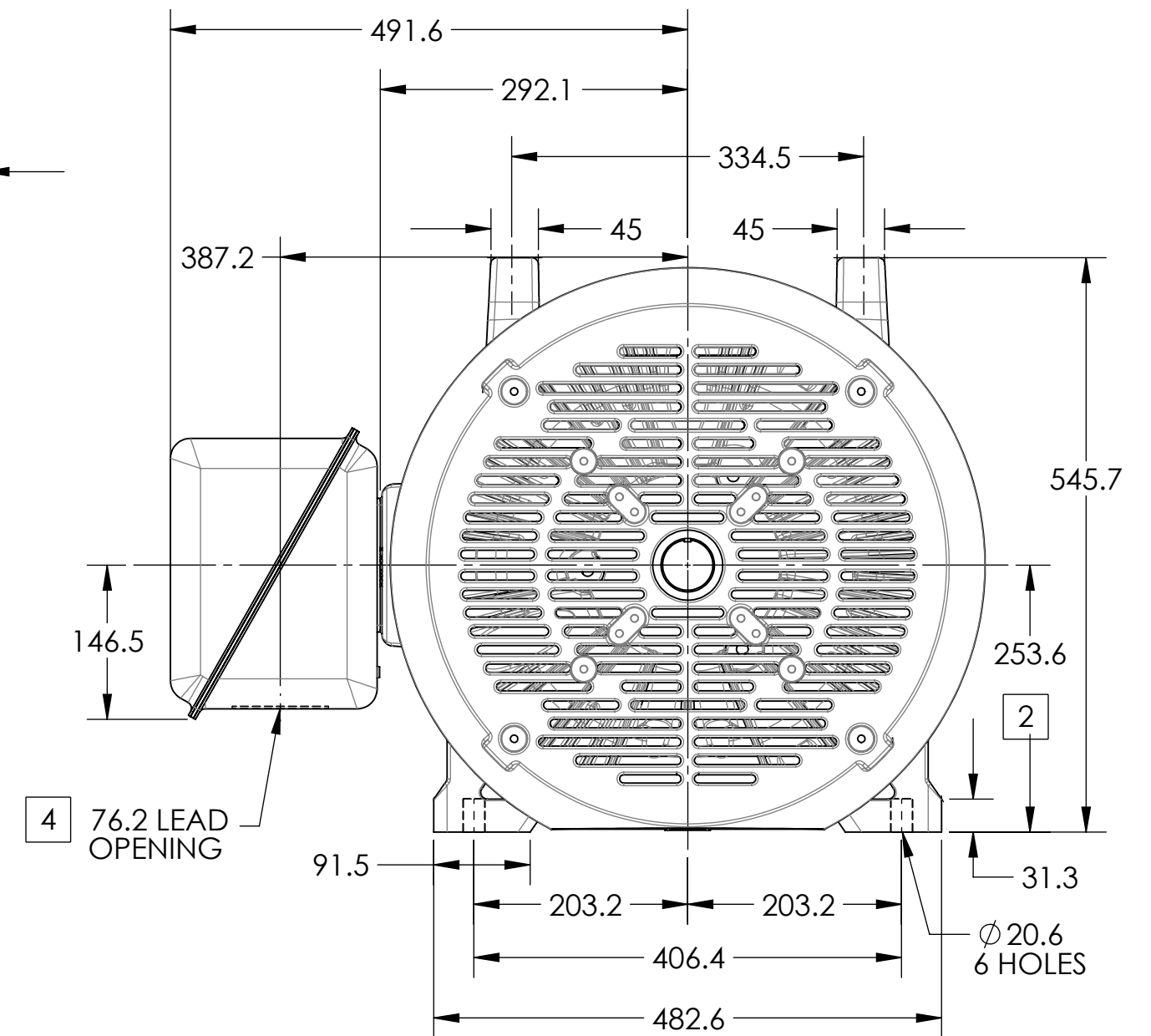
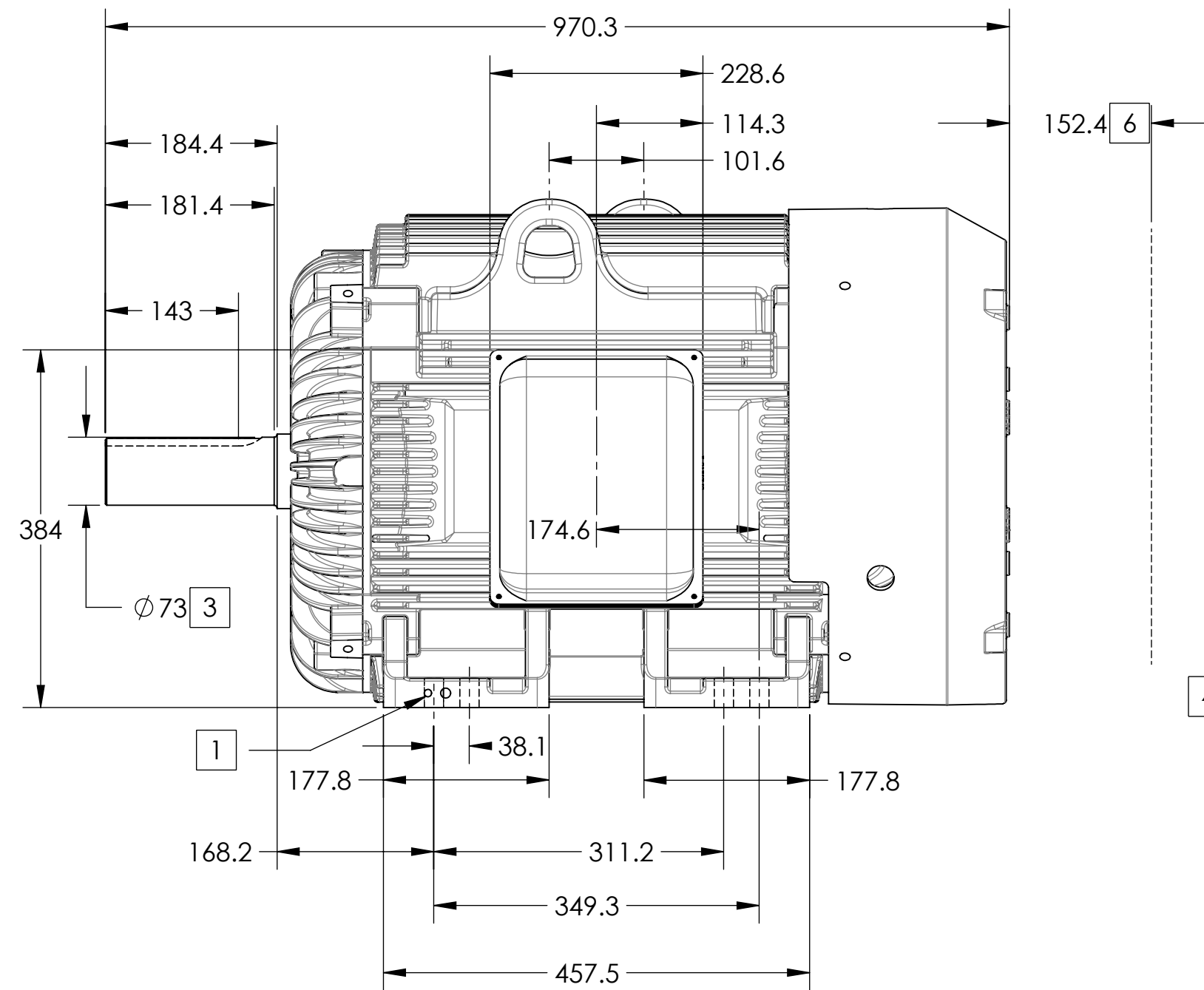
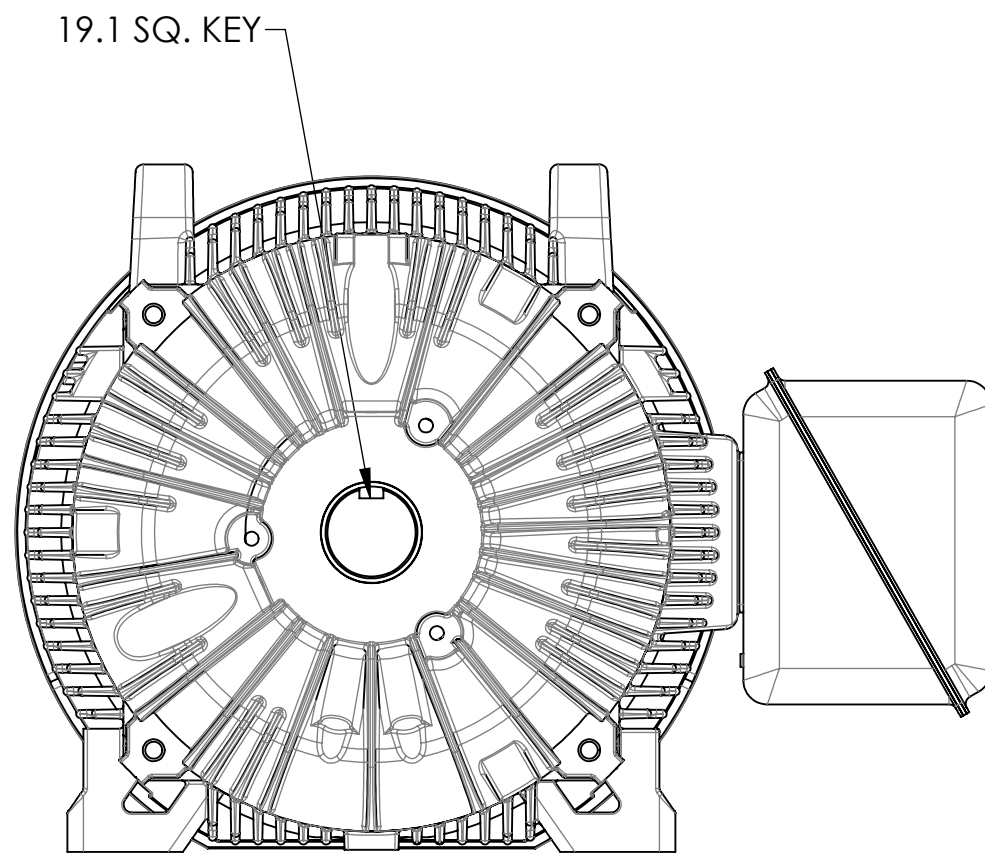

1. GROUND HOLES QTY 1 1/2-13 TAP; QTY 1 3/8-16 TAP
2. VARIES +.0,-1.5
3. VARIES +.00,-.03
4. ON STANDARD MOTORS THIS IS CONDUIT SIZE. ON XT AND CORROSION PROOF MOTOR THIS IS PIPE TAP.
5. MOTOR WEIGHTS MAY VARY BY 15% DEPENDING ON RATING.
6. OBSTRUCTION MUST NOT ENCROACH ON AIR INLET

5 WEIGHT (KGS): 620

CONDUIT BOX LOCATED ON OPPOSITE SIDE WHEN F-1.
IF MOUNTING CLEARANCE DETAILS ARE REQUIRED, CONSULT FACTORY.
MAXIMUM PERMISSIBLE SHAFT RUNOUT WHEN MEASURED AT END OF STANDARD SHAFT EXTENSION IS .08 MM T.I.R. TO 127 MM DIA.

DIMENSIONS ARE IN MILLIMETERS; SEE SHEET 1 FOR DIMENSIONS IN INCHES

CUSTOMER IS RESPONSIBLE FOR DETERMINING THAT MOTOR PERFORMANCE IS SUITABLE IN THE APPLICATION.

REV. DESC: CHANGE BA FROM 6.76 TO 6.62			
REV: A	VERSION: 01	REVISED: 11:53:40 04/14/2014	TDR: 000000848770
MODEL NO. 617429-011		REF:	
BY: MGHJMZ2	Material:		