

# DUTY MASTER ALTERNATING CURRENT MOTORS

## SQUIRREL-CAGE INDUCTION

ENCLOSURE: TOTALLY ENCLOSED  
MOUNTING: FOOT

FRAME G405T ABOVE NEMA RATINGS  
INCLUDES 404T FRAME MOUNTING HOLES

COOLING: FAN COOLED  
841XL ENCLOSURE ENHANCEMENT

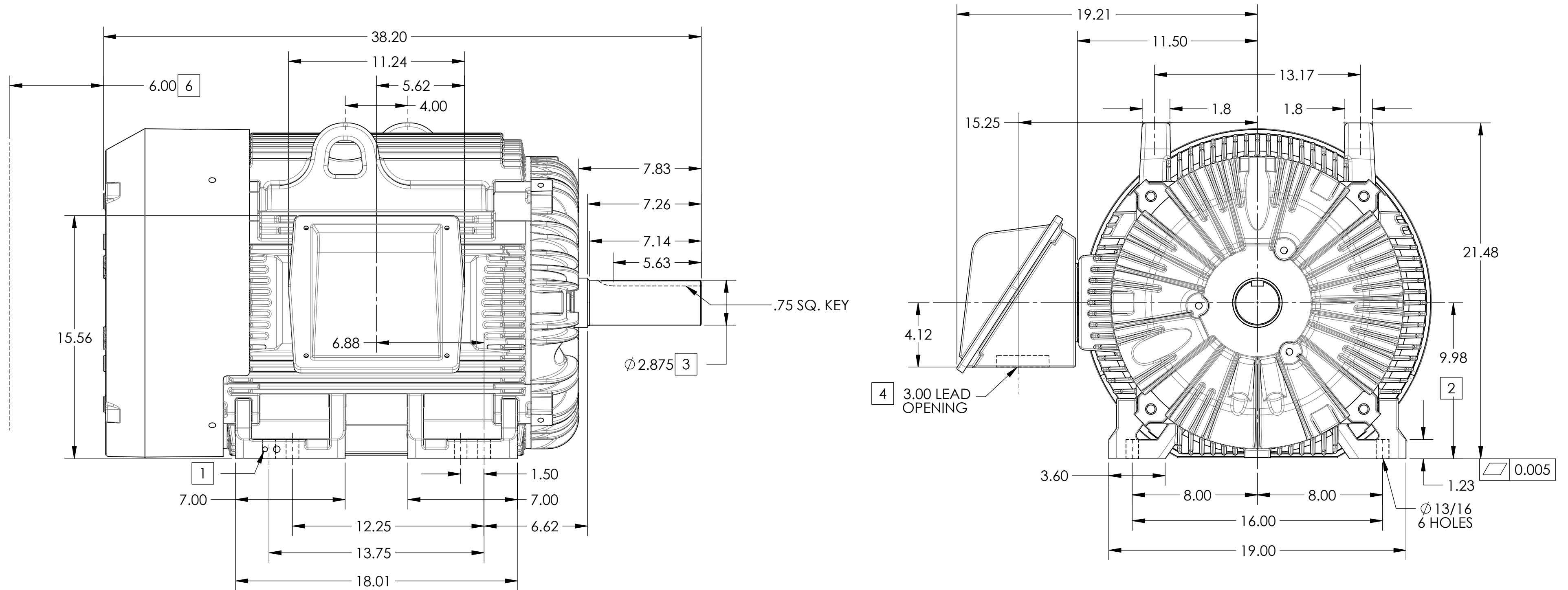

- 1. GROUND HOLES QTY 1 1/2-13 TAP; QTY 1 3/8-16 TAP
- 2. VARIES +.00,-.06
- 3. VARIES +.000,-.001
- 4. ON STANDARD MOTORS THIS IS CONDUIT SIZE. ON XT AND CORROSION PROOF MOTOR THIS IS PIPE TAP.
- 5. MOTOR WEIGHTS MAY VARY BY 15% DEPENDING ON RATING.
- 6. OBSTRUCTION MUST NOT ENCROACH ON AIR INLET

5 WEIGHT (LBS): 1370

CONDUIT BOX LOCATED ON OPPOSITE SIDE WHEN F-2.  
IF MOUNTING CLEARANCE DETAILS ARE REQUIRED, CONSULT FACTORY.  
MAXIMUM PERMISSIBLE SHAFT RUNOUT WHEN MEASURED AT END OF STANDARD SHAFT EXTENSION IS .0015" T.I.R. TO 5 INCH DIA.

DIMENSIONS ARE IN INCHES; SEE SHEET 2 FOR DIMENSIONS IN MILLIMETERS

CUSTOMER IS RESPONSIBLE FOR DETERMINING THAT MOTOR PERFORMANCE IS SUITABLE IN THE APPLICATION.

|  |             |                              |                   |
|--|-------------|------------------------------|-------------------|
| REV. DESC: CHANGE BA FROM 6.76 TO 6.62 |             |                              |                   |
| REV: B                                 | VERSION: 02 | REVISED: 02:36:17 04/14/2014 | TDR: 000000848770 |
| MODEL NO. 617429-511                   |             | REF:                         |                   |
| BY: MGHIMZ2                            | Material:   | C                            |                   |

# DUTY MASTER ALTERNATING CURRENT MOTORS

## SQUIRREL-CAGE INDUCTION

ENCLOSURE: TOTALLY ENCLOSED  
MOUNTING: FOOT

FRAME G405T ABOVE NEMA RATINGS  
INCLUDES 404T FRAME MOUNTING HOLES

COOLING: FAN COOLED  
841XL ENCLOSURE ENHANCEMENT

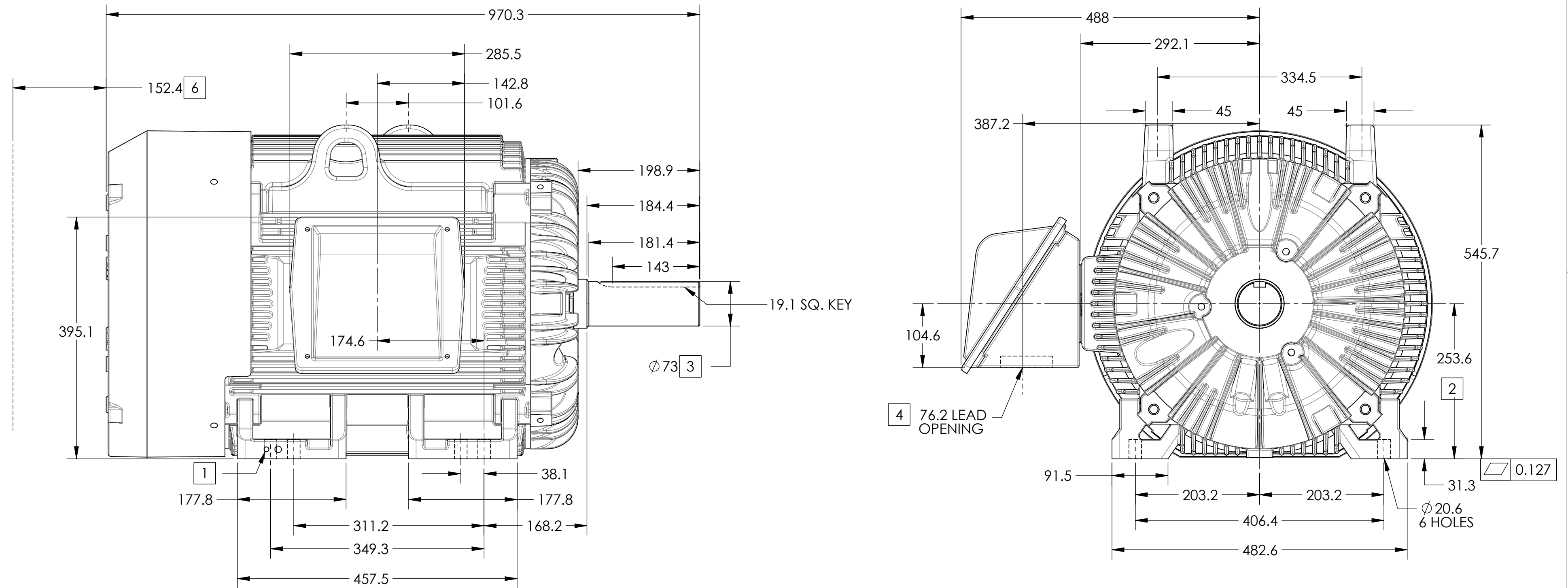

1. GROUND HOLES QTY 1 1/2-13 TAP; QTY 1 3/8-16 TAP
2. VARIES +.0,-1.5
3. VARIES +.00,-.03
4. ON STANDARD MOTORS THIS IS CONDUIT SIZE. ON XT AND CORROSION PROOF MOTOR THIS IS PIPE TAP.
5. MOTOR WEIGHTS MAY VARY BY 15% DEPENDING ON RATING.
6. OBSTRUCTION MUST NOT ENCROACH ON AIR INLET

**5** WEIGHT (KGS): 630

CONDUIT BOX LOCATED ON OPPOSITE SIDE WHEN F-2.  
IF MOUNTING CLEARANCE DETAILS ARE REQUIRED, CONSULT FACTORY.  
MAXIMUM PERMISSIBLE SHAFT RUNOUT WHEN MEASURED AT END OF STANDARD SHAFT EXTENSION IS .04 MM T.I.R. TO 127 MM DIA.

DIMENSIONS ARE IN MILLIMETERS; SEE SHEET 1 FOR DIMENSIONS IN INCHES

CUSTOMER IS RESPONSIBLE FOR DETERMINING THAT MOTOR PERFORMANCE IS SUITABLE IN THE APPLICATION.

|  |             |                              |                  |
|--|-------------|------------------------------|------------------|
| REV. DESC: CHANGE BA FROM 6.76 TO 6.62 |             |                              |                  |
| REV: B                                 | VERSION: 02 | REVISED: 02:36:17 04/14/2014 | TDR: 00000848770 |
| MODEL NO. 617429-511                   |             | REF:                         |                  |
| BY: MGHIMZ2                            | Material:   | C                            |                  |