

**TECHNICAL INFORMATION**

- BEARING LUBRICATION DE: MOBIL POLYREX EM  
ODE: MOBIL POLYREX EM
- BEARING TYPE DE: 6315C3  
ODE: 6315C3 INSULATED
- WINDING TEMP. DETECTORS  
NUMBER AND TYPE: 6xRTD(Pt0°C-100ohm)  
LOCATION: IN STATOR SLOT
- BEARING TEMP. DETECTORS  
NUMBER AND TYPE: N/A
- SPACE HEATER 1 PHASE  
VOLTS: 120 WATTS: 400
- ROTATION: CCW VIEWED FROM NON DRIVE END  
THIS MOTOR IS UNI DIRECTIONAL
- MOTOR PAINT COLOR: GRAY
- APPROX. WEIGHT: 5000 Lbs.
- ACCESORIES:

DRAWING LIST		NO.	REVISION	BY	DATE
MAIN TERMINAL BOX 130-7622-55					
AUX TERMINAL BOX FOR SPACE HEATER 130-7520-50 R.T.D. 130-7522-51 THERMISTOR -		1	GRS FROM SRI	RWS	1/2/14
PRODUCTION # -		0	FIRST ISSUE	MH	012904
UNITS:	INCHES	NO.	REVISION	BY	DATE

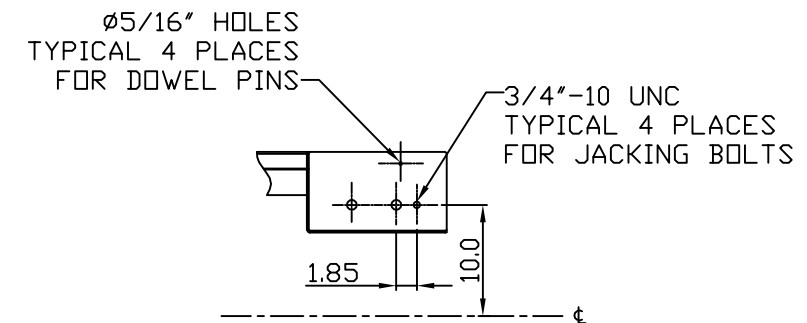

**MOTOR OUTLINE FOR  
THREE PHASE INDUCTION MOTOR**

CUSTOMER NAME				P.O. NO.	MOTOR TAG NO.	
OUTPUT HP	POLE	VOLTAGE V	FREQUENCY Hz	FULL LOAD SPEED (min <sup>-1</sup> )	TOSHIBA MODEL NO.	
TYPE	FORM	INS. CLASS F	RATING CONT.	FRAME 5011/12USS	S.F.	ENCLOSURE WP-II
<b>TOSHIBA INTERNATIONAL CORPORATION</b>						
<b>HOUSTON, TEXAS U.S.A.</b>						
3rd ANGLE PROJ.	PREPARED BY: M.HO	DATE: 012904	CHECKED BY: D. HENSLEY	DATE: 012904	DRAWING NO.:	REV.
					MDSL0087-05	1

**TYPICAL MOTOR PERFORMANCE DATA**

Model: 7003WTAK11F-C

HP	kW	Pole	FL RPM	Frame	Voltage	Hz	Phase	FL Amps
700	522	2	3574	5012USS	4000	60	3	92
Enclosure	IP	Ins. Class	S.F.	Duty	NEMA Nom. Eff.	NEMA Design	kVA Code	Ambient (°C)
WP-II	24	F	1.15	CONT	94.4	-	E	40 C

Load	HP	kW	Amperes	Efficiency (%)	Power Factor (%)
Full Load	700	522.0	91.0	94.4	87.7
¾ Load	525.00	391.5	70.3	94.1	85.4
½ Load	350.00	261.0	51.1	93.2	79.1
¼ Load	175.00	130.5	35.1	89.8	59.6
No Load			21.2		8.3
Locked Rotor			494.80		18.8

Torque				Rotor wk <sup>2</sup> Inertia (lb-ft <sup>2</sup> )
Full Load (lb-ft)	Locked Rotor (% FLT)	Pull Up (% FLT)	Break Down (% FLT)	
1029	85	90	250	114.85

Safe Stall Time(s)		Sound Pressure dB(A) @ 1M	Bearings*		Approx. Motor Weight (lbs)
Cold	Hot		DE	NDE	
23.7	13.6	-	6315C3	6315C3 INS	

\*Bearings are the only recommended spare part(s).

**Motor Options:**  
Product Family:WP-II  
Mounting:Footed,Shaft:USS Shaft

Customer	
Customer PO	
Sales Order	
Project #	

Tag:

All characteristics are average expected values.

**TOSHIBA INTERNATIONAL CORPORATION · HOUSTON, TEXAS U.S.A.**

Engineering	bmmammen	Doc. Written By	D. Suarez	Doc.# / Rev	MPCF-1119 / 0
Engr. Date	7/10/2014	Doc. Approved By	M. Campbell	Doc. Issued	6/8/2011

Issued Date	4/23/2015	Transmit #	
Issued By	dschoeck	Issued Rev	

**SPEED TORQUE/CURRENT CURVE**

Model: 7003WTAK11F-C

HP	kW	Pole	FL RPM	Frame	Voltage	Hz	Phase	FL Amps
700	522	2	3574	5012USS	4000	60	3	92
Enclosure	IP	Ins. Class	S.F.	Duty	NEMA Nom. Eff.	NEMA Design	kVA Code	Ambient (°C)
WP-II	24	F	1.15	CONT	94.4	-	E	40 C
Locked Rotor Amps	Rotor wk <sup>2</sup> Inertia (lb-ft <sup>2</sup> )	Torque						Break Down (%)
		Full Load (lb-ft)	Locked Rotor (%)	Pull Up (%)				
494.80	114.85	1029	85	90			250	

**Design Values**

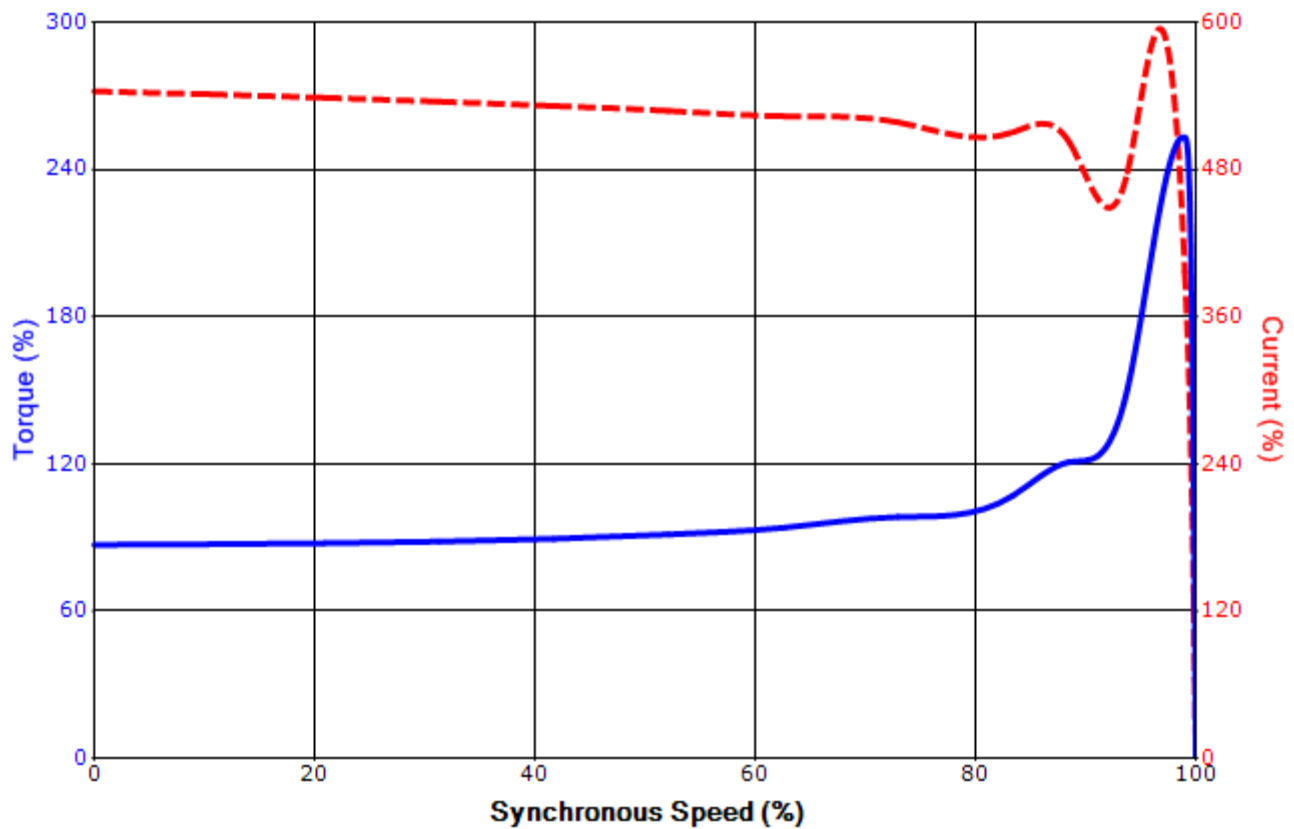

Customer		wk <sup>2</sup> Load Inertia (lb-ft <sup>2</sup> )	-
Customer PO		Load Type	-
Sales Order		Voltage (%)	100
Project #		Accel. Time	-

Tag:

All characteristics are average expected values.

**TOSHIBA INTERNATIONAL CORPORATION · HOUSTON, TEXAS U.S.A.**

Engineering	bmammen	Doc. Written By	D. Suarez	Doc.# / Rev	MPCF-1121 / 0
Engr. Date	7/10/2014	Doc. Approved By	M. Campbell	Doc. Issued	6/8/2011