

ROTATION  
UNITS  
BI-DIRECTIONAL  
SEE NOTE 6

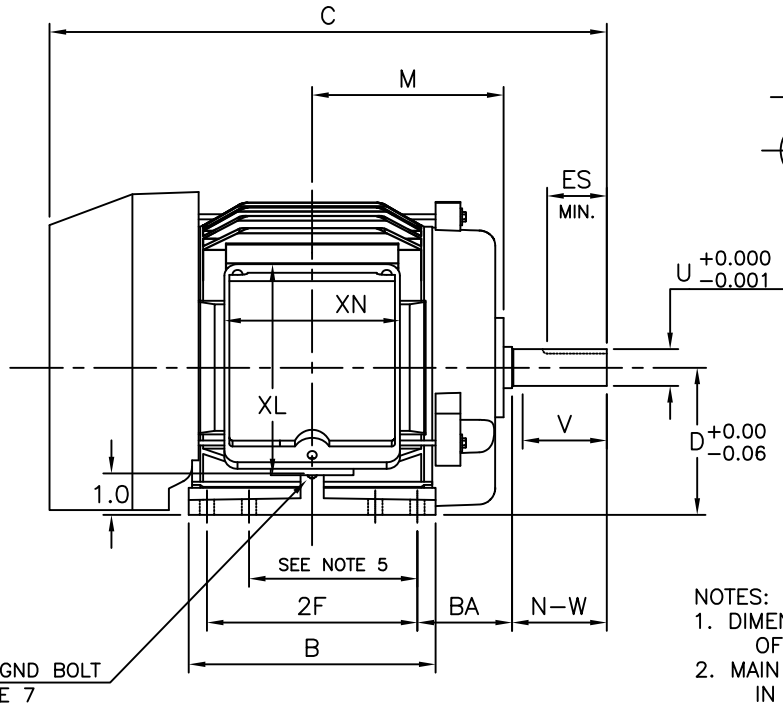
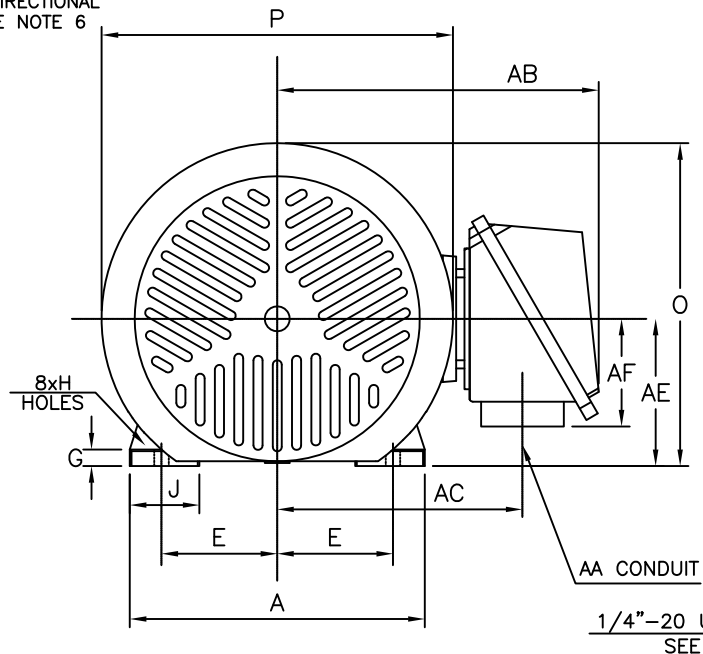

1/4"-20 UNC GND BOLT  
SEE NOTE 7

- NOTES:
1. DIMENSION V REPRESENTS LENGTH OF STRAIGHT PART OF SHAFT
  2. MAIN CONDUIT BOX MAY BE ROTATED IN 90° INCREMENTS
  3. KEY DIMENSIONS EQUAL S x S x 1.38 (MOTOR SUPPLIED WITH KEY)
  4. MOTOR WEIGHT SHOWN IS MAXIMUM HORSEPOWER IN FRAME
  5. THIS DIMENSION EQUALS 2F FOR 143T MOUNTING
  6. STANDARD PRODUCT USE BI-DIRECTIONAL FAN. OPPOSITE ROTATION AVAILABLE ONLY BY CONNECTION CHANGE
  7. FRAME GROUND BOLT STANDARD ON 841 PRODUCT

UNITS: INCHES

FRAME SIZE	MOTOR DIMENSIONS											CONDUIT BOX							
	A	B	C	D	G	J	K	M	O	P	T	AA[NPT]	AB	AC	AE	AF	XL	XN	
143T/145T	6.9	5.9	13.3	3.50	0.35	1.6	0	4.5	7.6	8.2	0	0.75	7.6	5.8	3.5	2.6	5.0	4.2	

FRAME SIZE	MOUNTING				SHAFT EXTENSION			KEY SEAT			BEARINGS		MAXIMUM WEIGHT
	E	2F	H	BA	N-W	V	U	R	S	ES	LS	OS	
143T/145T	2.75	4.00/5.00	0.34	2.25	2.25	2.00	0.875	0.771	0.188	1.41	6305UUC3	6305UUC3	75 lbs.

CUSTOMER: \_\_\_\_\_ MOTOR MODEL NO.: \_\_\_\_\_  
 P.O. NO.: \_\_\_\_\_ HP: \_\_\_\_\_ VOLTAGE: \_\_\_\_\_ RPM(SYN.): \_\_\_\_\_ Hz: \_\_\_\_\_  
 FRAME SIZE: \_\_\_\_\_ PRODUCT TYPE: EQP III 840 & 841  
 COMMENTS: \_\_\_\_\_  
 \_\_\_\_\_  
 PER: \_\_\_\_\_ DATE: \_\_\_\_\_

TAG NO's.:

STANDARD (NO AUX. BOXES)  
 RTD AUX. BOX  
 SPACE HEATER AUX. BOX  
 BEARING RTD's

TOSHIBA RESERVES THE RIGHT TO MAKE CHANGES OF TECHNICAL IMPROVEMENT AND THE DATA MAY CHANGE WITHOUT NOTICE  PRELIMINARY  
 DO NOT USE FOR CONSTRUCTION, INSTALLATION, OR APPLICATION PURPOSES UNLESS THE DRAWING IS MARKED AS CERTIFIED  CERTIFIED

**TOSHIBA**  
TOSHIBA INTERNATIONAL CORPORATION

TOTALLY-ENCLOSED FAN-COOLED  
HORIZONTAL FOOT-MOUNTED  
3 PHASE INDUCTION MOTOR  
F1 ASSEMBLY

**XT SERIES**  
VISIT OUR WEBSITE AT:  
www.toshiba.com/ind

**TYPICAL MOTOR PERFORMANCE DATA**

Model: B0014FLF10MHD02

HP	kW	Pole	FL RPM	Frame	Voltage	Hz	Phase	FL Amps
1	0.75	4	1749	143T	575	60	3	1.10
Enclosure	IP	Ins. Class	S.F.	Duty	NEMA Nom. Eff.	NEMA Design	kVA Code	Ambient (°C)
TEFC	54	F	1.15	CONT	85.5	B	K	40 C

Load	HP	kW	Amperes	Efficiency (%)	Power Factor (%)
Full Load	1	0.7	1.1	85.7	78.5
¾ Load	0.75	0.6	0.9	86.1	72.7
½ Load	0.50	0.4	0.7	82.3	59.8
¼ Load	0.25	0.2	0.6	71.7	38.7
No Load			0.6		9.6
Locked Rotor			8.80		67.3

Torque				Rotor wk <sup>2</sup> Inertia (lb-ft <sup>2</sup> )
Full Load (lb-ft)	Locked Rotor (% FLT)	Pull Up (% FLT)	Break Down (% FLT)	
3	335	325	365	0.13

Safe Stall Time(s)		Sound Pressure dB(A) @ 1M	Bearings*		Approx. Motor Weight (lbs)
Cold	Hot		DE	NDE	
32	15	-	6305UUC3	6305UUC3	

\*Bearings are the only recommended spare part(s).

**Motor Options:**  
Product Family:EQPIII 840  
Mounting:Footed,Shaft:T Shaft

Customer	
Customer PO	
Sales Order	
Project #	

Tag:

All characteristics are average expected values.

**TOSHIBA INTERNATIONAL CORPORATION · HOUSTON, TEXAS U.S.A.**

Engineering	aacosta	Doc. Written By	D. Suarez	Doc.# / Rev	MPCF-1119 / 0
Engr. Date	7/13/2012	Doc. Approved By	M. Campbell	Doc. Issued	6/8/2011

**SPEED TORQUE/CURRENT CURVE**

Model: B0014FLF10MHD02

HP	kW	Pole	FL RPM	Frame	Voltage	Hz	Phase	FL Amps
1	0.75	4	1749	143T	575	60	3	1.10
Enclosure	IP	Ins. Class	S.F.	Duty	NEMA Nom. Eff.	NEMA Design	kVA Code	Ambient (°C)
TEFC	54	F	1.15	CONT	85.5	B	K	40 C
Locked Rotor Amps	Rotor wk <sup>2</sup> Inertia (lb-ft <sup>2</sup> )	Torque						Break Down (%)
		Full Load (lb-ft)	Locked Rotor (%)	Pull Up (%)				
8.80	0.13	3	335	325			365	

**Design Values**

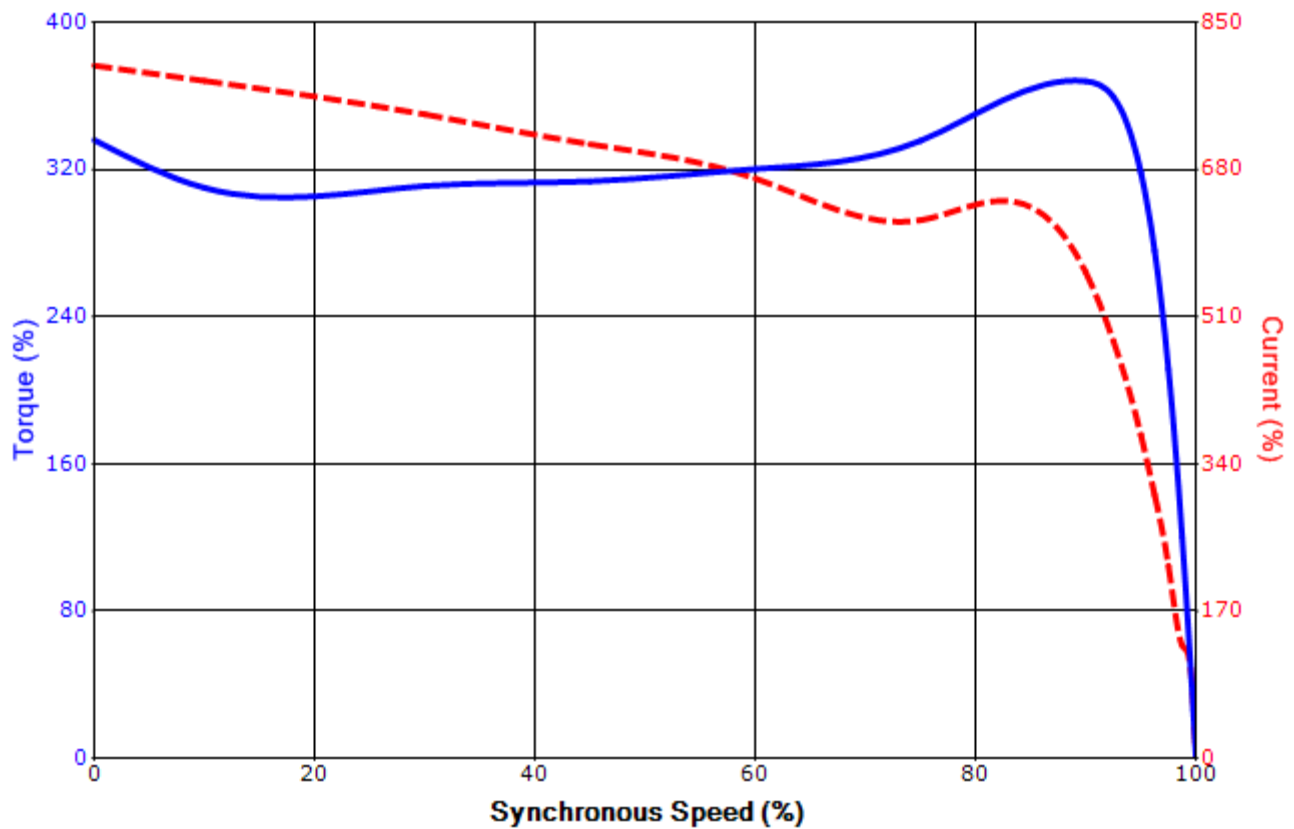

Customer		wk <sup>2</sup> Load Inertia (lb-ft <sup>2</sup> )	-
Customer PO		Load Type	-
Sales Order		Voltage (%)	100
Project #		Accel. Time	-

Tag:

All characteristics are average expected values.

**TOSHIBA INTERNATIONAL CORPORATION · HOUSTON, TEXAS U.S.A.**

Engineering	aacosta	Doc. Written By	D. Suarez	Doc.# / Rev	MPCF-1121 / 0
Engr. Date	7/13/2012	Doc. Approved By	M. Campbell	Doc. Issued	6/8/2011

### Motor Connection Diagram 3 Leads - Wye Connection



Switch L1 and L2 to reverse rotation

Each lead may consist of more than one cable.  
If multiple cables represent a single lead, each one  
of them will be labeled with the appropriate lead number.