

CLEARANCE REQUIRED TO REMOVE HOUSING

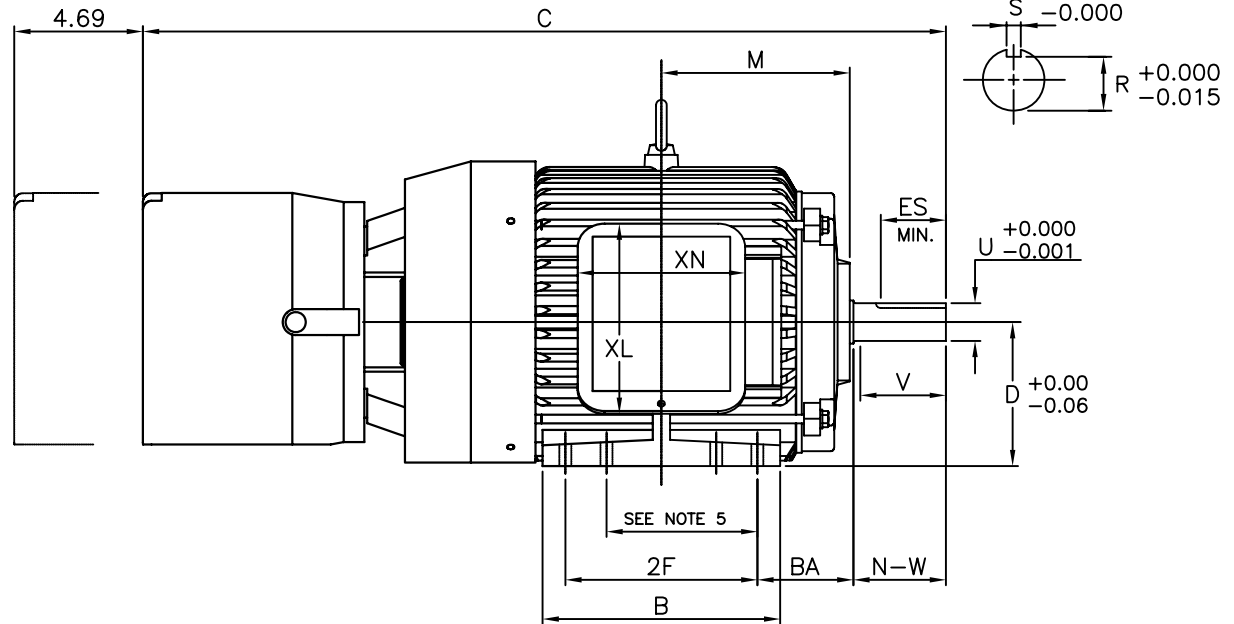
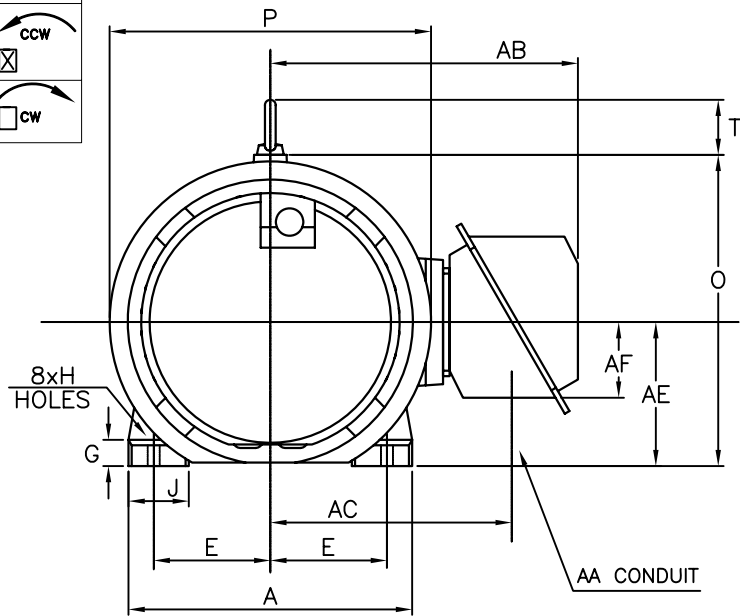

UNITS: INCHES

FRAME SIZE	MOTOR DIMENSIONS											CONDUIT BOX						
	A	B	C	D	G	J	K	M	O	P	T	AA	AB	AC	AE	AF	XL	XN
213T/215T	10.4	8.7	29.3	5.25	1.0	2.0	0	6.9	11.4	11.8	2.0	1.00	11.3	8.8	5.25	2.8	7.0	6.1

FRAME SIZE	MOUNTING			SHAFT EXTENSION				KEY SEAT			BEARINGS		MAXIMUM WEIGHT
	E	2F	H	BA	N-W	V	U	R	S	ES	LS	OS	
213T/215T	4.25	5.50/7.00	0.44	3.50	3.38	3.12	1.375	1.201	0.312	2.38	6308UU	6208UU	258 lbs.

NOTES:

1. DIMENSION V REPRESENTS LENGTH OF STRAIGHT PART OF SHAFT
2. MAIN CONDUIT BOX MAY BE ROTATED IN 90° INCREMENTS
3. KEY DIMENSIONS EQUAL S x S x 2.38 (MOTOR SUPPLIED WITH KEY)
4. MOTOR WEIGHT SHOWN IS MAXIMUM HORSEPOWER IN FRAME
5. THIS DIMENSION EQUALS 2F FOR 213T MOUNTING
6. STANDARD PRODUCT USE BI-DIRECTIONAL FAN. OPPOSITE ROTATION AVAILABLE ONLY BY CONNECTION CHANGE

CUSTOMER: _____ MOTOR MODEL NO.: B00365LF2OMH

P.O. NO.: _____ HP: 3 VOLTAGE: 575 RPM(SYN.): 1200 Hz: 60

FRAME SIZE: 213T PRODUCT TYPE: TEFC EQP III, EPACT, & HIGH EFFICIENCY BRAKE SERIES

COMMENTS: 87,000 SERIES STEARNS BRAKE

TAG NO's: _____

- STANDARD (NO AUX. BOXES)
- RTD AUX. BOX
- SPACE HEATER AUX. BOX
- BEARING RTD's

PER: _____ DATE: _____

TOSHIBA RESERVES THE RIGHT TO MAKE CHANGES OF TECHNICAL IMPROVEMENT AND THE DATA MAY CHANGE WITHOUT NOTICE PRELIMINARY

DO NOT USE FOR CONSTRUCTION, INSTALLATION, OR APPLICATION PURPOSES UNLESS THE DRAWING IS MARKED AS CERTIFIED CERTIFIED

TOSHIBA

TOSHIBA INTERNATIONAL CORPORATION

TOTALLY-ENCLOSED FAN-COOLED
HORIZONTAL FOOT-MOUNTED
3 PHASE INDUCTION MOTOR
F1 ASSEMBLY

XT SERIES

VISIT OUR WEBSITE AT:
www.toshiba.com/ind

TOSHIBA INTERNATIONAL CORPORATION
Industrial Division / Houston Motor Plant

**SQUIRREL CAGE INDUCTION MOTOR
 PERFORMANCE SPECIFICATIONS**

INDEX	MPCF-1033
SHEET NO.	1 of 1
ISSUED	11/08/96
SUPERSEDES	10/06/95
REVISION	1
WRITTEN BY	R. EVANS
APPROVED BY	<i>Jay Bugbee</i>

Customer Tag:

CUSTOMER:
 TIC SR No.:
 Customer PO:

MOTOR NAMEPLATE DATA

H.P.: 3	VOLTS: 575	3 Ø / 60	Hz	S. RPM: 1200
FRAME: 213T	ENCL: TEFC	FLAMPS: 3.3		FLRPM: 1165
FORM: FCK1	S.F.: 1.15	NEMA DESIGN: B		INSUL CLASS: F
TYPE: IKH	AMB.: 40	CODE: K		DUTY: CONT.
MODEL No.: B00365LF2OMH		kW:		Serial No.:
NOM. EFF.:	MIN. EFF.: 89.5	P.F.: 78.0		

AMPERAGE Locked Rotor: 26.00	TORQUES FULL LOAD (lb-ft.): 13.50 LOCKED ROTOR (%): 279 BREAK DOWN (%): 352.00	** BEARINGS: Drive End: 6308UU Opposite Drive End: 6208UU
--	--	--

EFFICIENCY (%) FULL LOAD: 90.3 3/4 LOAD: 91.0 1/2 LOAD: 89.9	POWER FACTOR (%) FULL LOAD: 78.0 3/4 LOAD: 70.0 1/2 LOAD: 57.7
--	--

ALL CHARACTERISTICS ARE AVERAGE EXPECTED VALUES BASED UPON RATED VOLTAGE, FREQUENCY AND SINEWAVE POWER INPUT.

* TEMPERATURE RISE WILL BE CONSISTENT WITH INSULATION, AMBIENT AND SERVICE FACTOR AS DEFINED BY NEMA-MG-12.43 OR -20.40.

** BEARINGS ARE THE ONLY RECOMMENDED SPARE PART(S).

CERTIFIED BY:
DATE:

TOSHIBA

Reliability in Motion

TOSHIBA INTERNATIONAL CORPORATION

INDUSTRIAL DIVISION

PO BOX 40906

HOUSTON TX 77240

(713) 466-0277

(800) 231-1412

FAX (713) 466-8773

SPARE PARTS (RECOMMENDED)

OTHER THAN THE GREASE USED FOR RE-GREASABLE BEARINGS, **TOSHIBA** ADVISES THAT THERE ARE NO "USE" PARTS. THE ONLY INSURANCE SPARES THAT **TOSHIBA** SUGGESTS FOR THESE SQUIRREL CAGE INDUCTION MOTORS ARE INDUSTRY STANDARD, AND COMMERCIALY AVAILABLE ANTI-FRICTION BEARINGS, AS NOTED BELOW.

MOTOR COMPONENTS (SUCH AS TERMINAL BOXES, FAN COVERS, MACHINED PARTS) ARE AVAILABLE UPON SPECIAL REQUEST. IN THIS CASE, PLEASE ADVISE OUR ORDER ENTRY DEPARTMENT THE MODEL AND SERIAL NUMBERS (FOUND ON THE MOTOR NAMEPLATE) , AND A DESCRIPTION OF THE COMPONENT REQUIRED. THEY WILL THEN FURNISH THE CURRENT PART NUMBER, PRICE AND AVAILABILITY.

(NOTE: OUR INTERNAL PART NUMBERS ARE SUBJECT TO CHANGE WITHOUT NOTICE, AND ARE NOT PUBLISHED).

PLEASE ADVISE IF YOU HAVE ANY QUESTIONS.

CUSTOMER:
PURCHASE ORDER #
Customer Tag:

TOSHIBA FILE #
MODEL # B00365LF2OMH
HP / RPM / ENCL / FRAME: 3 / 1200 / TEFC / 213T
DRIVE END BEARING: 6308UU
OPPOSITE DRIVE END BEARING: 6208UU

Prepared By:
Date:

Three Phase Motor Wiring Diagram
"Across the line" (Full Voltage) Starting

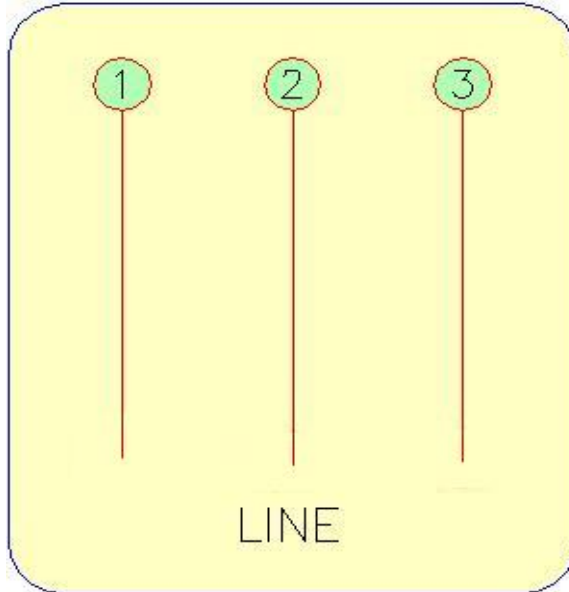

Customer Name:	
PO No.:	
Customer Tag:	
TIC File No.:	
Motor Model No.	B00365LF2OMH

For Further Information Regarding Toshiba motor starting, maintenance or wiring,
Please refer to the "Toshiba - A Quality Product for World Energy" Installation and
Maintenance Manual, or contact the Toshiba Low Voltage Motor Marketing Department.
(800) 231-1412

Prepared By:
Date: