

ROTATION
UNITS
BI-DIRECTIONAL
SEE NOTE 6

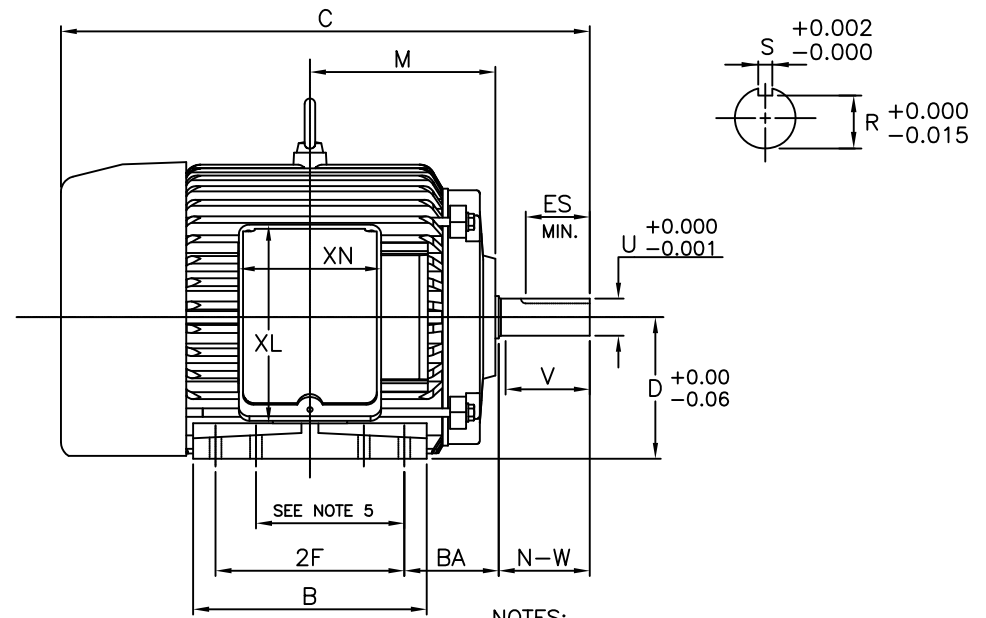
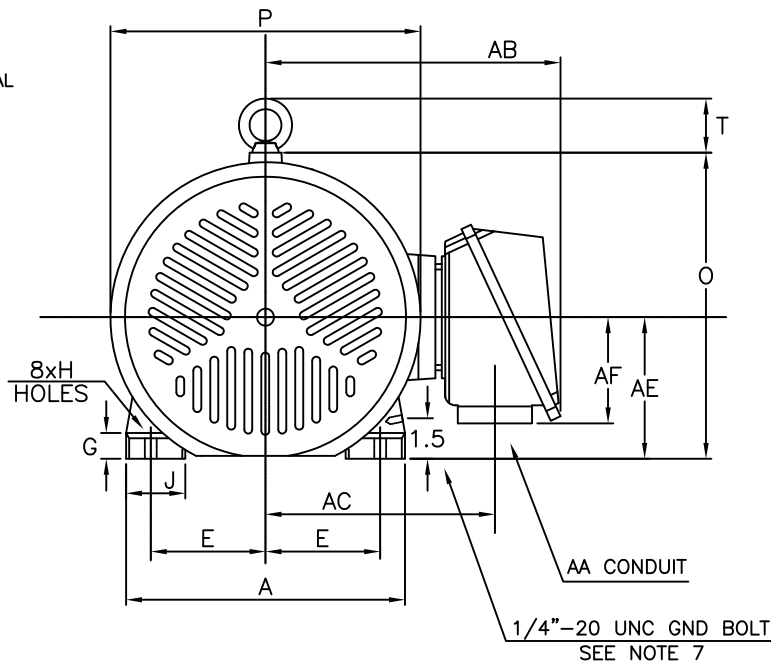

- NOTES:
1. DIMENSION V REPRESENTS LENGTH OF STRAIGHT PART OF SHAFT
 2. MAIN CONDUIT BOX MAY BE ROTATED IN 90° INCREMENTS
 3. KEY DIMENSIONS EQUAL S x S x 2.38 (MOTOR SUPPLIED WITH KEY)
 4. MOTOR WEIGHT SHOWN IS MAXIMUM HORSEPOWER IN FRAME
 5. THIS DIMENSION EQUALS 2F FOR 213T MOUNTING
 6. STANDARD PRODUCT USE BI-DIRECTIONAL FAN. OPPOSITE ROTATION AVAILABLE ONLY BY CONNECTION CHANGE
 7. FRAME GROUND BOLT STANDARD ON 841 PRODUCT

UNITS: INCHES

FRAME SIZE	MOTOR DIMENSIONS											CONDUIT BOX							
	A	B	C	D	G	J	K	M	O	P	T	AA[NPT]	AB	AC	AE	AF	XL	XN	
213T/215T	10.4	8.7	19.8	5.25	1.0	2.0	0	6.9	11.4	11.5	2.0	1.00	10.9	8.5	5.25	3.9	7.4	5.3	

FRAME SIZE	MOUNTING				SHAFT EXTENSION			KEY SEAT			BEARINGS			MAXIMUM WEIGHT
	E	2F	H	BA	N-W	V	U	R	S	ES	LS	OS	OS 2P	
213T/215T	4.25	5.50/7.00	0.44	3.50	3.38	3.12	1.375	1.201	0.312	2.38	6308C3	6308C3	6308ZC3	202 lbs.

CUSTOMER: _____ MOTOR MODEL NO.: _____
 P.O. NO.: _____ HP: _____ VOLTAGE: _____ RPM(SYN.): _____ Hz: _____
 FRAME SIZE: _____ PRODUCT TYPE: EQP III 840 & 841
 COMMENTS: _____

TAG NO's.: _____

PER: _____ DATE: _____

- STANDARD (NO AUX. BOXES)
 RTD AUX. BOX
 SPACE HEATER AUX. BOX
 BEARING RTD's

TOSHIBA RESERVES THE RIGHT TO MAKE CHANGES OF TECHNICAL IMPROVEMENT AND THE DATA MAY CHANGE WITHOUT NOTICE PRELIMINARY

DO NOT USE FOR CONSTRUCTION, INSTALLATION, OR APPLICATION PURPOSES UNLESS THE DRAWING IS MARKED AS CERTIFIED CERTIFIED

TOSHIBA

TOSHIBA INTERNATIONAL CORPORATION

TOTALLY-ENCLOSED FAN-COOLED
 HORIZONTAL FOOT-MOUNTED
 3 PHASE INDUCTION MOTOR
 F1 ASSEMBLY

XT SERIES

VISIT OUR WEBSITE AT:
www.toshiba.com/ind

TYPICAL MOTOR PERFORMANCE DATA

Model: B0038FLF3BMHJ

HP	kW	Pole	FL RPM	Frame	Voltage	Hz	Phase	FL Amps
3	2.2	8	870	215T	230/460	60	3	10/5
Enclosure	IP	Ins. Class	S.F.	Duty	NEMA Nom. Eff.	NEMA Design	kVA Code	Ambient (°C)
TEFC	55	F	1.15	CONT	87.5	B	J	40 C

Load	HP	kW	Amperes	Efficiency (%)	Power Factor (%)
Full Load	3	2.2	4.9	87.8	64.1
¾ Load	2.25	1.7	4.3	86.5	55.7
½ Load	1.50	1.1	3.8	82.7	43.7
¼ Load	0.75	0.6	3.5	71.3	27.8
No Load			3.3		3.5
Locked Rotor			30.00		50.1

Torque				Rotor wk ² Inertia (lb-ft ²)
Full Load (lb-ft)	Locked Rotor (% FLT)	Pull Up (% FLT)	Break Down (% FLT)	
18.1	275	335	365	1.56

Safe Stall Time(s)		Sound Pressure dB(A) @ 1M	Bearings*		Approx. Motor Weight (lbs)
Cold	Hot		DE	NDE	
32	15	-	6308C3	6308C3	

*Bearings are the only recommended spare part(s).

Motor Options:
Product Family:EQPIII 841
Mounting:Footed,Shaft:T Shaft

Customer	
Customer PO	
Sales Order	
Project #	

Tag:

All characteristics are average expected values.

TOSHIBA INTERNATIONAL CORPORATION · HOUSTON, TEXAS U.S.A.

Engineering	aacosta	Doc. Written By	D. Suarez	Doc.# / Rev	MPCF-1119 / 0
Engr. Date	6/18/2012	Doc. Approved By	M. Campbell	Doc. Issued	6/8/2011

Issued Date	4/23/2015	Transmit #	
Issued By	dschoeck	Issued Rev	

SPEED TORQUE/CURRENT CURVE

Model: B0038FLF3BMHJ

HP	kW	Pole	FL RPM	Frame	Voltage	Hz	Phase	FL Amps
3	2.2	8	870	215T	230/460	60	3	10/5
Enclosure	IP	Ins. Class	S.F.	Duty	NEMA Nom. Eff.	NEMA Design	kVA Code	Ambient (°C)
TEFC	55	F	1.15	CONT	87.5	B	J	40 C
Locked Rotor Amps	Rotor wk ² Inertia (lb-ft ²)	Torque						Break Down (%)
		Full Load (lb-ft)	Locked Rotor (%)	Pull Up (%)				
30.00	1.56	18.1	275	335			365	

Design Values

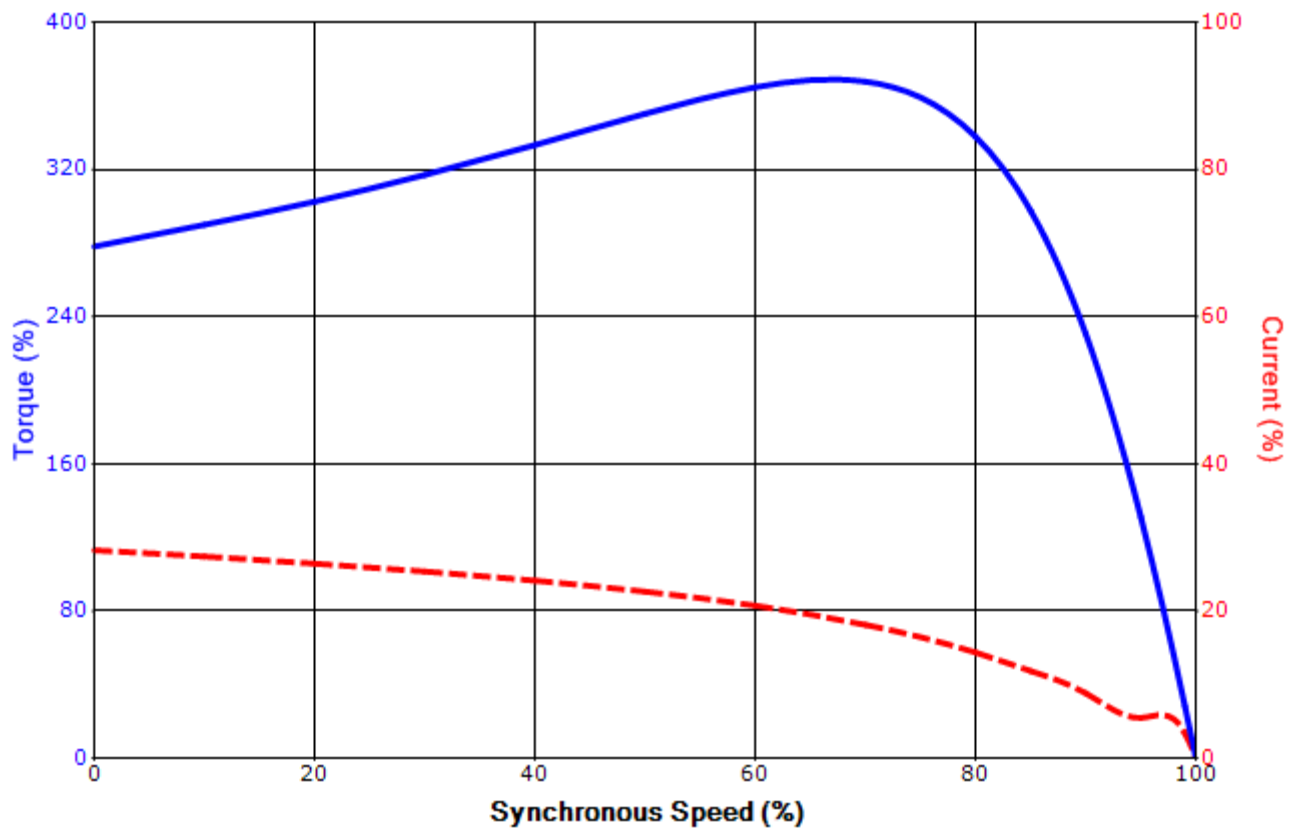

Customer		wk ² Load Inertia (lb-ft ²)	-
Customer PO		Load Type	-
Sales Order		Voltage (%)	100
Project #		Accel. Time	-

Tag:

All characteristics are average expected values.

TOSHIBA INTERNATIONAL CORPORATION · HOUSTON, TEXAS U.S.A.

Engineering	aacosta	Doc. Written By	D. Suarez	Doc.# / Rev	MPCF-1121 / 0
Engr. Date	6/18/2012	Doc. Approved By	M. Campbell	Doc. Issued	6/8/2011

Motor Connection Diagram 3 Leads - Wye Connection



Switch L1 and L2 to reverse rotation

Each lead may consist of more than one cable.
If multiple cables represent a single lead, each one
of them will be labeled with the appropriate lead number.