

ROTATION
UNITS
BI-DIRECTIONAL
SEE NOTE 6

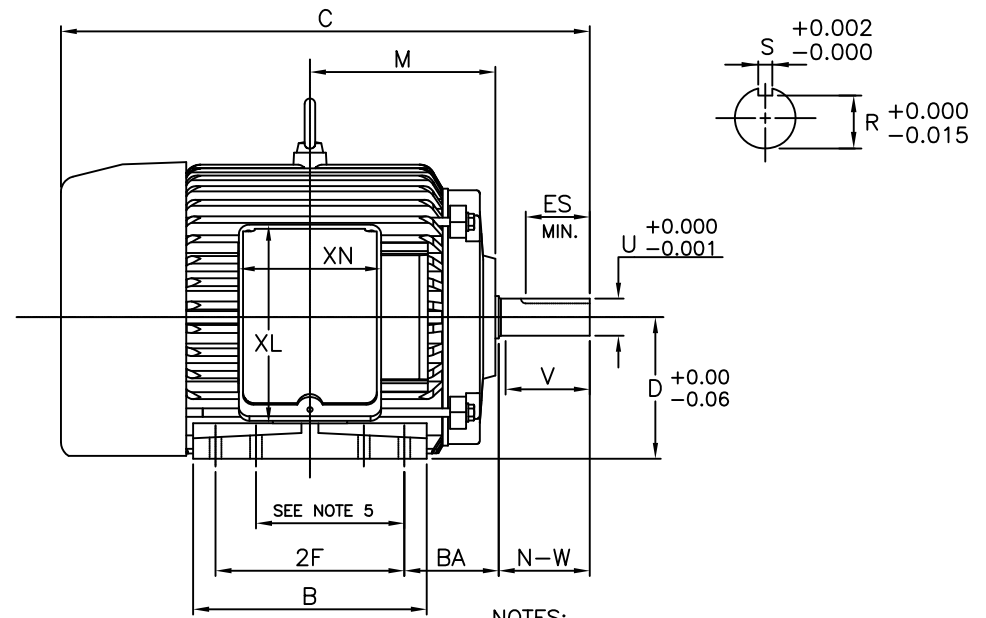
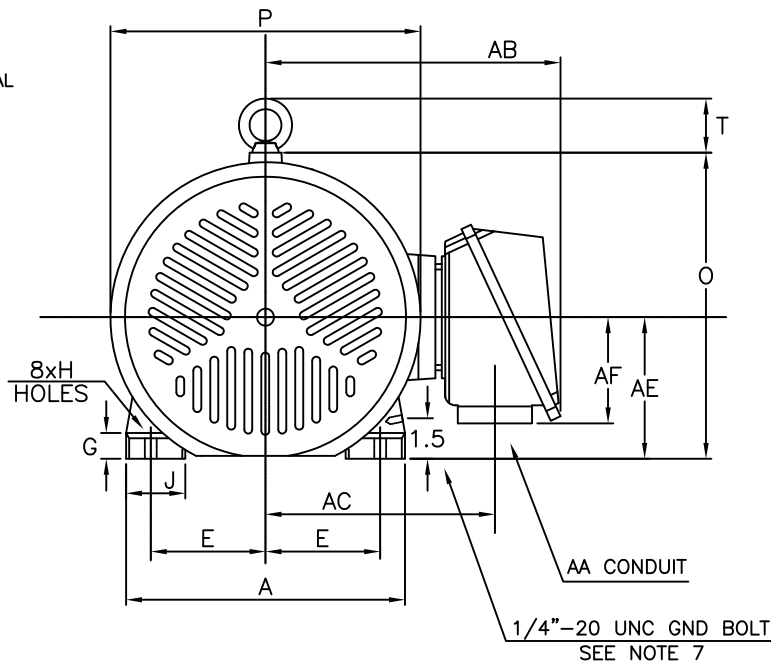

- NOTES:
1. DIMENSION V REPRESENTS LENGTH OF STRAIGHT PART OF SHAFT
 2. MAIN CONDUIT BOX MAY BE ROTATED IN 90° INCREMENTS
 3. KEY DIMENSIONS EQUAL S x S x 2.38 (MOTOR SUPPLIED WITH KEY)
 4. MOTOR WEIGHT SHOWN IS MAXIMUM HORSEPOWER IN FRAME
 5. THIS DIMENSION EQUALS 2F FOR 213T MOUNTING
 6. STANDARD PRODUCT USE BI-DIRECTIONAL FAN. OPPOSITE ROTATION AVAILABLE ONLY BY CONNECTION CHANGE
 7. FRAME GROUND BOLT STANDARD ON 841 PRODUCT

UNITS: INCHES

FRAME SIZE	MOTOR DIMENSIONS											CONDUIT BOX							
	A	B	C	D	G	J	K	M	O	P	T	AA[NPT]	AB	AC	AE	AF	XL	XN	
213T/215T	10.4	8.7	19.8	5.25	1.0	2.0	0	6.9	11.4	11.5	2.0	1.00	10.9	8.5	5.25	3.9	7.4	5.3	

FRAME SIZE	MOUNTING				SHAFT EXTENSION			KEY SEAT			BEARINGS			MAXIMUM WEIGHT
	E	2F	H	BA	N-W	V	U	R	S	ES	LS	OS	OS 2P	
213T/215T	4.25	5.50/7.00	0.44	3.50	3.38	3.12	1.375	1.201	0.312	2.38	6308C3	6308C3	6308ZC3	202 lbs.

CUSTOMER: _____ MOTOR MODEL NO.: _____
 P.O. NO.: _____ HP: _____ VOLTAGE: _____ RPM(SYN.): _____ Hz: _____
 FRAME SIZE: _____ PRODUCT TYPE: EQP III 840 & 841
 COMMENTS: _____

TAG NO's.: _____

PER: _____ DATE: _____

- STANDARD (NO AUX. BOXES)
- RTD AUX. BOX
- SPACE HEATER AUX. BOX
- BEARING RTD's

TOSHIBA RESERVES THE RIGHT TO MAKE CHANGES OF TECHNICAL IMPROVEMENT AND THE DATA MAY CHANGE WITHOUT NOTICE PRELIMINARY

DO NOT USE FOR CONSTRUCTION, INSTALLATION, OR APPLICATION PURPOSES UNLESS THE DRAWING IS MARKED AS CERTIFIED CERTIFIED

TOSHIBA

TOSHIBA INTERNATIONAL CORPORATION

TOTALLY-ENCLOSED FAN-COOLED
HORIZONTAL FOOT-MOUNTED
3 PHASE INDUCTION MOTOR
F1 ASSEMBLY

XT SERIES

VISIT OUR WEBSITE AT:
www.toshiba.com/ind

TYPICAL MOTOR PERFORMANCE DATA

Model: B0102FLF1BMHD04

HP	kW	Pole	FL RPM	Frame	Voltage	Hz	Phase	FL Amps
10	7.5	2	3510	215T	460	60	3	12
Enclosure	IP	Ins. Class	S.F.	Duty	NEMA Nom. Eff.	NEMA Design	kVA Code	Ambient (°C)
TEFC	54	F	1.15	CONT	90.2	B	H	40 C

Load	HP	kW	Amperes	Efficiency (%)	Power Factor (%)
Full Load	10	7.5	11.5	90.3	89.7
¾ Load	7.50	5.6	8.8	90.0	87.6
½ Load	5.00	3.7	6.4	88.0	81.7
¼ Load	2.50	1.9	4.5	81.7	63.1
No Load			2.9		53.6
Locked Rotor			81.00		37.8

Torque				Rotor wk ²
Full Load (lb-ft)	Locked Rotor (% FLT)	Pull Up (% FLT)	Break Down (% FLT)	Inertia (lb-ft ²)
15	210	220	300	0.64

Safe Stall Time(s)		Sound Pressure dB(A) @ 1M	Bearings*		Approx. Motor Weight (lbs)
Cold	Hot		DE	NDE	
21	10	-	6308UU	6308UU	

*Bearings are the only recommended spare part(s).

Motor Options:
Product Family:EQPIII 840
Mounting:Footed,Shaft:T Shaft

Customer	
Customer PO	
Sales Order	
Project #	

Tag:

All characteristics are average expected values.

TOSHIBA INTERNATIONAL CORPORATION · HOUSTON, TEXAS U.S.A.

Engineering	gminetos	Doc. Written By	D. Suarez	Doc.# / Rev	MPCF-1119 / 0
Engr. Date	6/26/2013	Doc. Approved By	M. Campbell	Doc. Issued	6/8/2011

SPEED TORQUE/CURRENT CURVE

Model: B0102FLF1BMHD04

HP	kW	Pole	FL RPM	Frame	Voltage	Hz	Phase	FL Amps
10	7.5	2	3510	215T	460	60	3	12
Enclosure	IP	Ins. Class	S.F.	Duty	NEMA Nom. Eff.	NEMA Design	kVA Code	Ambient (°C)
TEFC	54	F	1.15	CONT	90.2	B	H	40 C
Locked Rotor Amps	Rotor wk ² Inertia (lb-ft ²)	Torque						Break Down (%)
		Full Load (lb-ft)	Locked Rotor (%)	Pull Up (%)				
81.00	0.64	15	210	220			300	

Design Values

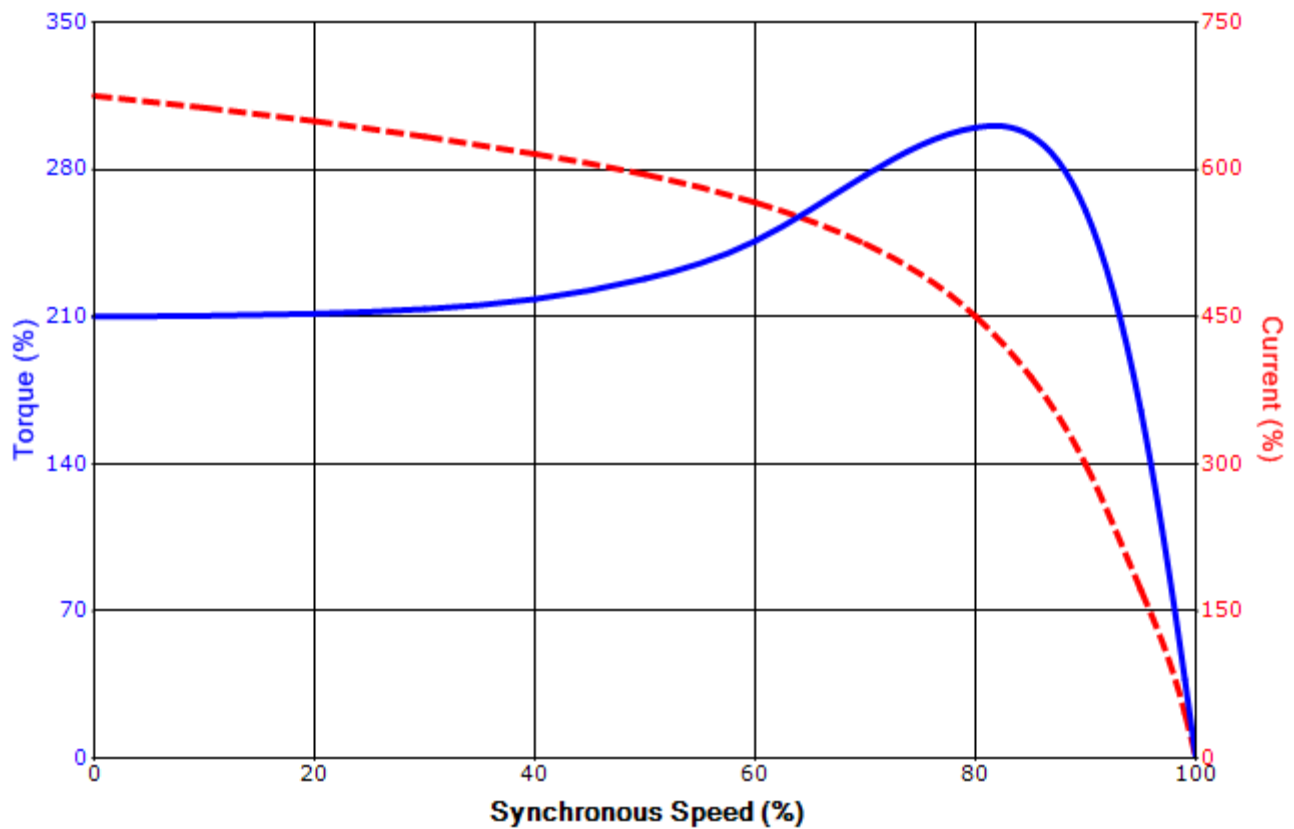

Customer		wk ² Load Inertia (lb-ft ²)	-
Customer PO		Load Type	-
Sales Order		Voltage (%)	100
Project #		Accel. Time	-

Tag:

All characteristics are average expected values.

TOSHIBA INTERNATIONAL CORPORATION · HOUSTON, TEXAS U.S.A.

Engineering	gminetos	Doc. Written By	D. Suarez	Doc.# / Rev	MPCF-1121 / 0
Engr. Date	6/26/2013	Doc. Approved By	M. Campbell	Doc. Issued	6/8/2011

Motor Connection Diagram 3 Leads - Delta Connection



Switch L1 and L2 to reverse rotation

Each lead may consist of more than one cable.
If multiple cables represent a single lead, each one
of them will be labeled with the appropriate lead number.