

ROTATION
UNITS
BI-DIRECTIONAL
SEE NOTE 6

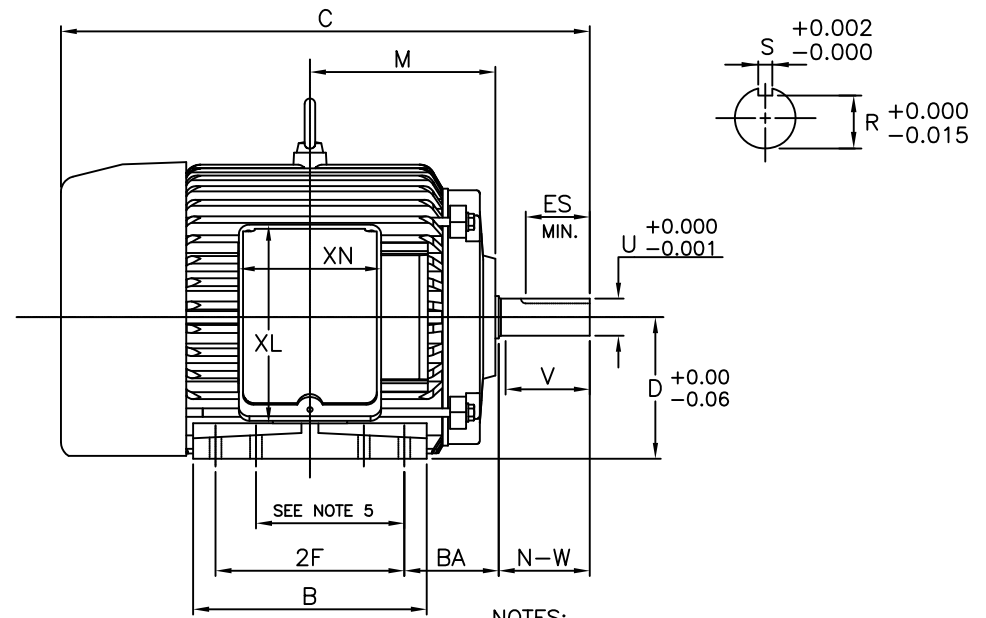
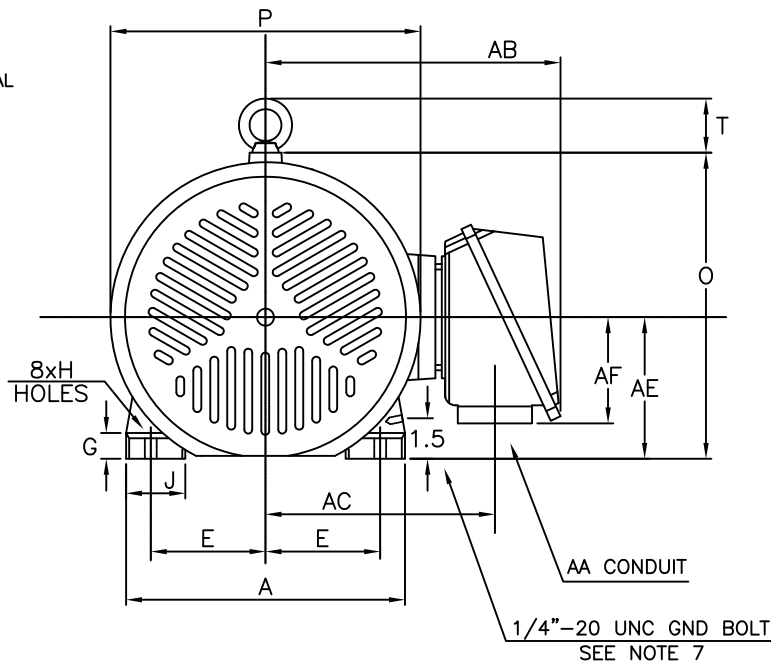

- NOTES:
1. DIMENSION V REPRESENTS LENGTH OF STRAIGHT PART OF SHAFT
 2. MAIN CONDUIT BOX MAY BE ROTATED IN 90° INCREMENTS
 3. KEY DIMENSIONS EQUAL S x S x 2.38 (MOTOR SUPPLIED WITH KEY)
 4. MOTOR WEIGHT SHOWN IS MAXIMUM HORSEPOWER IN FRAME
 5. THIS DIMENSION EQUALS 2F FOR 213T MOUNTING
 6. STANDARD PRODUCT USE BI-DIRECTIONAL FAN. OPPOSITE ROTATION AVAILABLE ONLY BY CONNECTION CHANGE
 7. FRAME GROUND BOLT STANDARD ON 841 PRODUCT

UNITS: INCHES

| FRAME SIZE | MOTOR DIMENSIONS | | | | | | | | | | | CONDUIT BOX | | | | | | | |
|------------|------------------|-----|------|------|-----|-----|---|-----|------|------|-----|-------------|------|-----|------|-----|-----|-----|--|
| | A | B | C | D | G | J | K | M | O | P | T | AA[NPT] | AB | AC | AE | AF | XL | XN | |
| 213T/215T | 10.4 | 8.7 | 19.8 | 5.25 | 1.0 | 2.0 | 0 | 6.9 | 11.4 | 11.5 | 2.0 | 1.00 | 10.9 | 8.5 | 5.25 | 3.9 | 7.4 | 5.3 | |

| FRAME SIZE | MOUNTING | | | | SHAFT EXTENSION | | | KEY SEAT | | | BEARINGS | | | MAXIMUM WEIGHT |
|------------|----------|-----------|------|------|-----------------|------|-------|----------|-------|------|----------|--------|---------|----------------|
| | E | 2F | H | BA | N-W | V | U | R | S | ES | LS | OS | OS 2P | |
| 213T/215T | 4.25 | 5.50/7.00 | 0.44 | 3.50 | 3.38 | 3.12 | 1.375 | 1.201 | 0.312 | 2.38 | 6308C3 | 6308C3 | 6308ZC3 | 202 lbs. |

CUSTOMER: _____ MOTOR MODEL NO.: _____
 P.O. NO.: _____ HP: _____ VOLTAGE: _____ RPM(SYN.): _____ Hz: _____
 FRAME SIZE: _____ PRODUCT TYPE: EQP III 840 & 841
 COMMENTS: _____

TAG NO's.: _____

PER: _____ DATE: _____

- STANDARD (NO AUX. BOXES)
 RTD AUX. BOX
 SPACE HEATER AUX. BOX
 BEARING RTD's

TOSHIBA RESERVES THE RIGHT TO MAKE CHANGES OF TECHNICAL IMPROVEMENT AND THE DATA MAY CHANGE WITHOUT NOTICE PRELIMINARY

DO NOT USE FOR CONSTRUCTION, INSTALLATION, OR APPLICATION PURPOSES UNLESS THE DRAWING IS MARKED AS CERTIFIED CERTIFIED

TOSHIBA

TOSHIBA INTERNATIONAL CORPORATION

TOTALLY-ENCLOSED FAN-COOLED
 HORIZONTAL FOOT-MOUNTED
 3 PHASE INDUCTION MOTOR
 F1 ASSEMBLY

XT SERIES

VISIT OUR WEBSITE AT:
www.toshiba.com/ind

TYPICAL MOTOR PERFORMANCE DATA

Model: B0104FLF1OSHD04

| HP | kW | Pole | FL RPM | Frame | Voltage | Hz | Phase | FL Amps |
|-----------|-----|------------|--------|-------|----------------|-------------|----------|--------------|
| 10 | 7.5 | 4 | 1746 | 215T | 575 | 60 | 3 | 10 |
| Enclosure | IP | Ins. Class | S.F. | Duty | NEMA Nom. Eff. | NEMA Design | kVA Code | Ambient (°C) |
| TEFC | 54 | F | 1.15 | CONT | 91.7 | B | H | 40 C |

| Load | HP | kW | Amperes | Efficiency (%) | Power Factor (%) |
|--------------|------|-----|---------|----------------|------------------|
| Full Load | 10 | 7.5 | 9.6 | 91.9 | 86.0 |
| ¾ Load | 7.50 | 5.6 | 7.4 | 91.8 | 82.0 |
| ½ Load | 5.00 | 3.7 | 5.6 | 90.5 | 72.8 |
| ¼ Load | 2.50 | 1.9 | 4.3 | 85.1 | 50.9 |
| No Load | | | 3.3 | | 5.8 |
| Locked Rotor | | | 64.80 | | 48.0 |

| Torque | | | | Rotor wk ² Inertia (lb-ft ²) |
|----------------------|-------------------------|--------------------|-----------------------|---|
| Full Load (lb-ft) | Locked Rotor (% FLT) | Pull Up (% FLT) | Break Down (% FLT) | |
| 30.1 | 285 | 305 | 360 | 1.47 |

| Safe Stall Time(s) | | Sound Pressure dB(A) @ 1M | Bearings* | | Approx. Motor Weight (lbs) |
|--------------------|-----|------------------------------|-----------|--------|-------------------------------|
| Cold | Hot | | DE | NDE | |
| 32 | 15 | - | 6308UU | 6308UU | |

*Bearings are the only recommended spare part(s).

Motor Options:
Mounting:Footed,Shaft:T Shaft

| | |
|-------------|--|
| Customer | |
| Customer PO | |
| Sales Order | |
| Project # | |

Tag:

All characteristics are average expected values.

TOSHIBA INTERNATIONAL CORPORATION · HOUSTON, TEXAS U.S.A.

| | | | | | |
|-------------|-----------|------------------|-------------|-------------|---------------|
| Engineering | aacosta | Doc. Written By | D. Suarez | Doc.# / Rev | MPCF-1119 / 0 |
| Engr. Date | 7/16/2012 | Doc. Approved By | M. Campbell | Doc. Issued | 6/8/2011 |

SPEED TORQUE/CURRENT CURVE

Model: B0104FLF1OSHD04

| | | | | | | | | |
|-------------------|---|-------------------|------------------|-------------|----------------|-------------|----------|----------------|
| HP | kW | Pole | FL RPM | Frame | Voltage | Hz | Phase | FL Amps |
| 10 | 7.5 | 4 | 1746 | 215T | 575 | 60 | 3 | 10 |
| Enclosure | IP | Ins. Class | S.F. | Duty | NEMA Nom. Eff. | NEMA Design | kVA Code | Ambient (°C) |
| TEFC | 54 | F | 1.15 | CONT | 91.7 | B | H | 40 C |
| Locked Rotor Amps | Rotor wk ² Inertia (lb-ft ²) | Torque | | | | | | Break Down (%) |
| | | Full Load (lb-ft) | Locked Rotor (%) | Pull Up (%) | | | | |
| 64.80 | 1.47 | 30.1 | 285 | 305 | | | 360 | |

Design Values

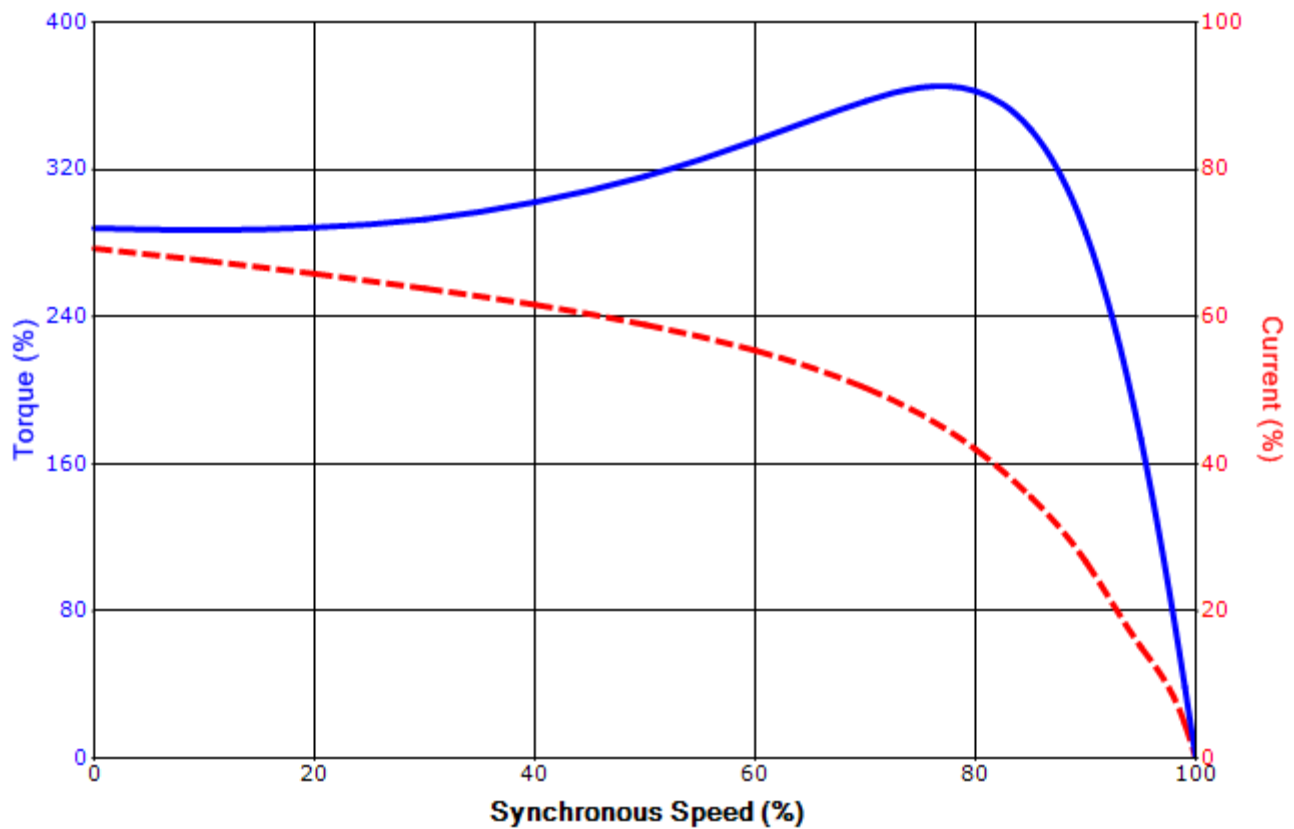

| | | | |
|-------------|--|--|-----|
| Customer | | wk ² Load Inertia (lb-ft ²) | - |
| Customer PO | | Load Type | - |
| Sales Order | | Voltage (%) | 100 |
| Project # | | Accel. Time | - |

Tag:

All characteristics are average expected values.

TOSHIBA INTERNATIONAL CORPORATION · HOUSTON, TEXAS U.S.A.

| | | | | | |
|-------------|-----------|------------------|-------------|-------------|---------------|
| Engineering | aacosta | Doc. Written By | D. Suarez | Doc.# / Rev | MPCF-1121 / 0 |
| Engr. Date | 7/16/2012 | Doc. Approved By | M. Campbell | Doc. Issued | 6/8/2011 |

Motor Connection Diagram
3 Leads - Delta Connection



Switch L1 and L2 to reverse rotation

Each lead may consist of more than one cable.
If multiple cables represent a single lead, each one
of them will be labeled with the appropriate lead number.