

ROTATION
UNITS
BI-DIRECTIONAL
SEE NOTE 6

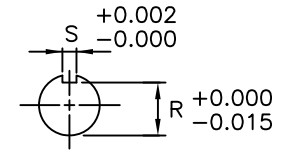
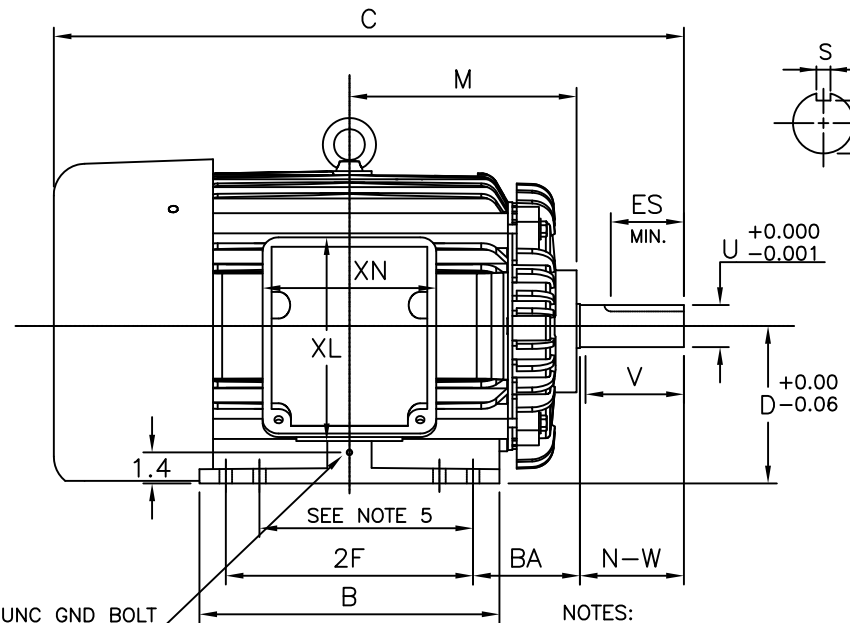

1/4"-20 UNC GND BOLT
SEE NOTE 7

NOTES:

1. DIMENSION V REPRESENTS LENGTH OF STRAIGHT PART OF SHAFT
2. MAIN CONDUIT BOX MAY BE ROTATED IN 90° INCREMENTS
3. KEY DIMENSIONS EQUAL S x S x 3.25 FOR T AND S x S x 1.87 FOR TS (MOTOR SUPPLIED WITH KEY)
4. MOTOR WEIGHT SHOWN IS MAXIMUM HORSEPOWER IN FRAME
5. THIS DIMENSION EQUALS 2F FOR 284T/TS MOUNTING
6. STANDARD PRODUCT USE BI-DIRECTIONAL FAN. OPPOSITE ROTATION AVAILABLE ONLY BY CONNECTION CHANGE
7. FRAME GROUND BOLT STANDARD ON 841 PRODUCT

UNITS: INCHES

FRAME SIZE	MOTOR DIMENSIONS											CONDUIT BOX						
	A	B	C	D	G	J	K	M	O	P	T	AA[NPT]	AB	AC	AE	AF	XL	XN
284TS/286TS	13.1	13.4	26.7	7.00	0.7	2.4	0	10.1	13.9	14.9	2.4	1.50	13.6	10.3	7.00	5.1	9.1	7.7
284T/286T	13.1	13.4	28.0	7.00	0.7	2.4	0	10.1	13.9	14.9	2.4	1.50	13.6	10.3	7.00	5.1	9.1	7.7

FRAME SIZE	MOUNTING				SHAFT EXTENSION			KEY SEAT			BEARINGS		MAXIMUM WEIGHT
	E	2F	H	BA	N-W	V	U	R	S	ES	LS	OS	
284TS/286TS	5.50	9.50/11.00	0.56	4.75	3.25	3.00	1.625	1.416	0.375	1.88	6310C3	6310C3	471 lbs.
284T/286T	5.50	9.50/11.00	0.56	4.75	4.62	4.38	1.875	1.591	0.500	3.25	6310C3	6310C3	471 lbs.

CUSTOMER: _____ MOTOR MODEL NO.: _____
 P.O. NO.: _____ HP: _____ VOLTAGE: _____ RPM(SYN.): _____ Hz: _____
 FRAME SIZE: _____ PRODUCT TYPE: EQP III 840 & 841
 COMMENTS: _____

TAG NO's.: _____

PER: _____ DATE: _____

- STANDARD (NO AUX. BOXES)
- RTD AUX. BOX
- SPACE HEATER AUX. BOX
- BEARING RTD's

TOSHIBA RESERVES THE RIGHT TO MAKE CHANGES OF TECHNICAL IMPROVEMENT AND THE DATA MAY CHANGE WITHOUT NOTICE PRELIMINARY

DO NOT USE FOR CONSTRUCTION, INSTALLATION, OR APPLICATION PURPOSES UNLESS THE DRAWING IS MARKED AS CERTIFIED CERTIFIED

TOSHIBA

TOSHIBA INTERNATIONAL CORPORATION

TOTALLY-ENCLOSED FAN-COOLED
HORIZONTAL FOOT-MOUNTED
3 PHASE INDUCTION MOTOR
F1 ASSEMBLY

XT SERIES

VISIT OUR WEBSITE AT:
www.toshiba.com/ind

TYPICAL MOTOR PERFORMANCE DATA

Model: B0206FLF3BMHD02

HP	kW	Pole	FL RPM	Frame	Voltage	Hz	Phase	FL Amps
20	15	6	1170	286T	230/460	60	3	50/25
Enclosure	IP	Ins. Class	S.F.	Duty	NEMA Nom. Eff.	NEMA Design	kVA Code	Ambient (°C)
TEFC	54	F	1.15	CONT	91.7	B	G	40 C

Load	HP	kW	Amperes	Efficiency (%)	Power Factor (%)
Full Load	20	14.9	25.0	91.7	83.5
¾ Load	15.00	11.2	19.5	92.4	80.2
½ Load	10.00	7.5	15.1	92.2	72.2
¼ Load	5.00	3.7	11.8	83.6	47.3
No Load			10.0		5.0
Locked Rotor			145.00		39.8

Torque				Rotor wk ² Inertia (lb-ft ²)
Full Load (lb-ft)	Locked Rotor (% FLT)	Pull Up (% FLT)	Break Down (% FLT)	
89.8	235	260	325	5.30

Safe Stall Time(s)		Sound Pressure dB(A) @ 1M	Bearings*		Approx. Motor Weight (lbs)
Cold	Hot		DE	NDE	
32	15	-	6310C3TMB	6310C3	

*Bearings are the only recommended spare part(s).

Motor Options:
Product Family:EQPIII 840
Mounting:Footed,Shaft:T Shaft

Customer	
Customer PO	
Sales Order	
Project #	

Tag:

All characteristics are average expected values.

TOSHIBA INTERNATIONAL CORPORATION · HOUSTON, TEXAS U.S.A.

Engineering	aacosta	Doc. Written By	D. Suarez	Doc.# / Rev	MPCF-1119 / 0
Engr. Date	7/12/2012	Doc. Approved By	M. Campbell	Doc. Issued	6/8/2011

SPEED TORQUE/CURRENT CURVE

Model: B0206FLF3BMHD02

HP	kW	Pole	FL RPM	Frame	Voltage	Hz	Phase	FL Amps
20	15	6	1170	286T	230/460	60	3	50/25
Enclosure	IP	Ins. Class	S.F.	Duty	NEMA Nom. Eff.	NEMA Design	kVA Code	Ambient (°C)
TEFC	54	F	1.15	CONT	91.7	B	G	40 C
Locked Rotor Amps	Rotor wk ² Inertia (lb-ft ²)	Torque						Break Down (%)
		Full Load (lb-ft)	Locked Rotor (%)	Pull Up (%)				
145.00	5.30	89.8	235	260			325	

Design Values

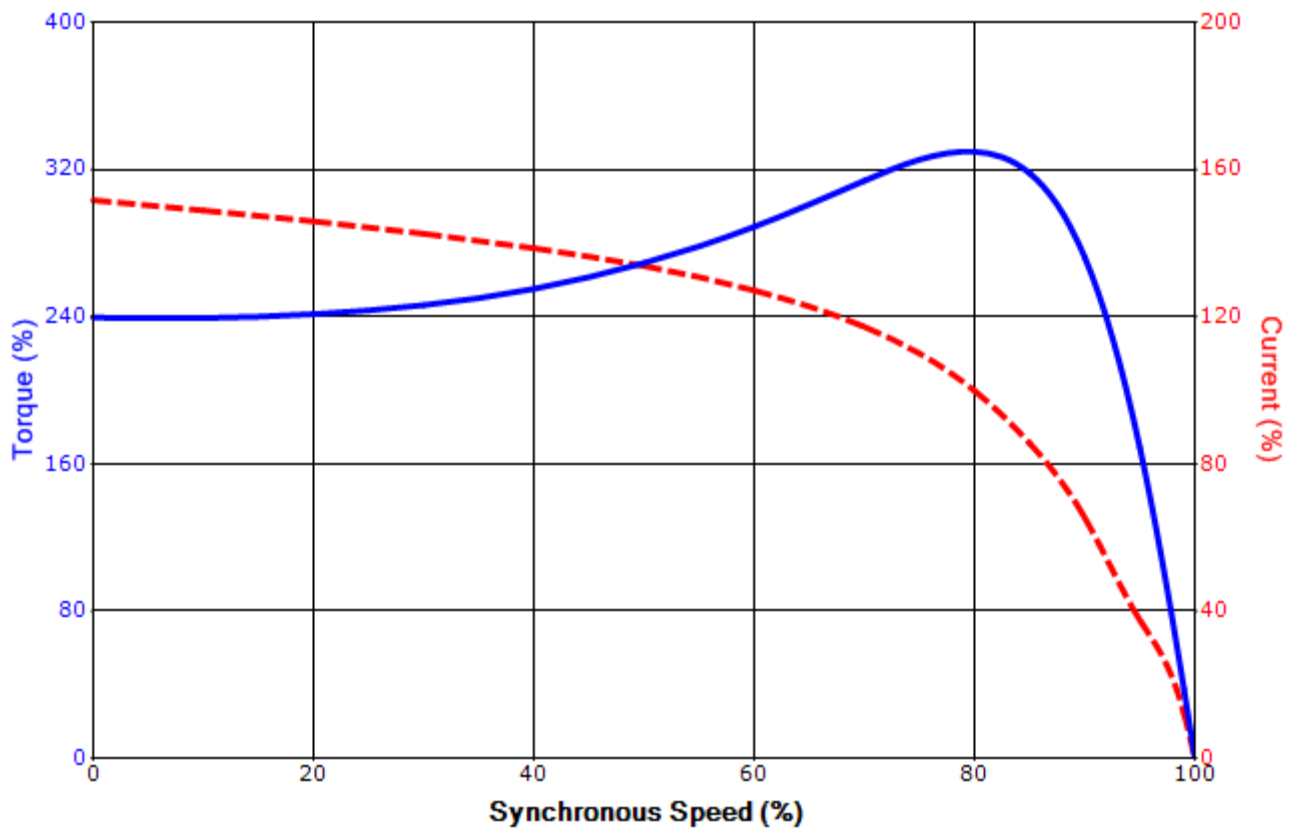

Customer		wk ² Load Inertia (lb-ft ²)	-
Customer PO		Load Type	-
Sales Order		Voltage (%)	100
Project #		Accel. Time	-

Tag:

All characteristics are average expected values.

TOSHIBA INTERNATIONAL CORPORATION · HOUSTON, TEXAS U.S.A.

Engineering	aacosta	Doc. Written By	D. Suarez	Doc.# / Rev	MPCF-1121 / 0
Engr. Date	7/12/2012	Doc. Approved By	M. Campbell	Doc. Issued	6/8/2011

Motor Connection Diagram
3 Leads - Delta Connection



Switch L1 and L2 to reverse rotation

Each lead may consist of more than one cable.
If multiple cables represent a single lead, each one
of them will be labeled with the appropriate lead number.