

ROTATION  
UNITS  
BI-DIRECTIONAL  
SEE NOTE 6

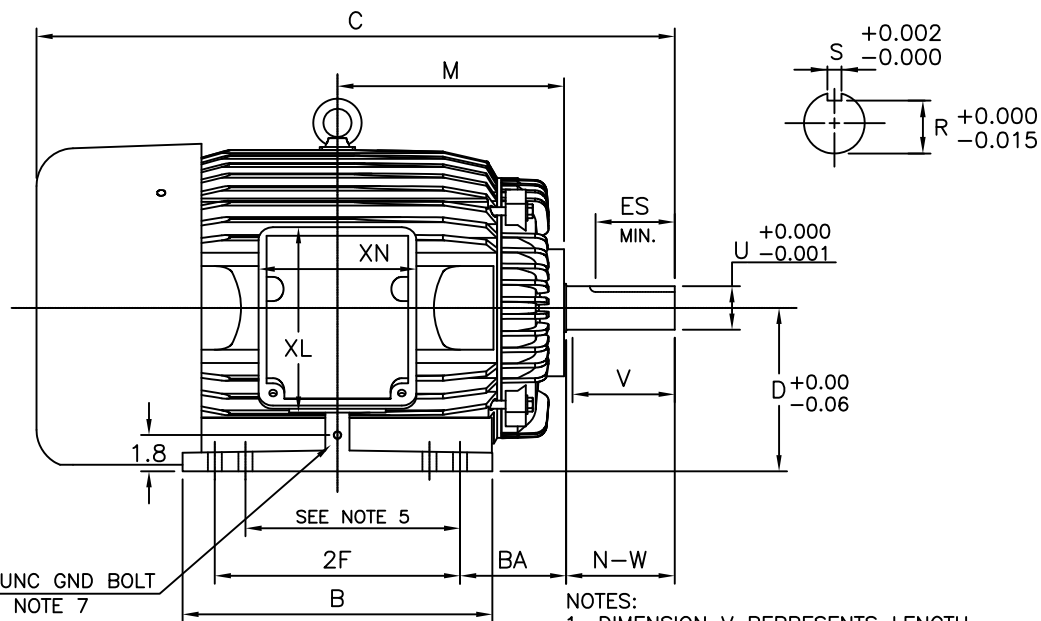
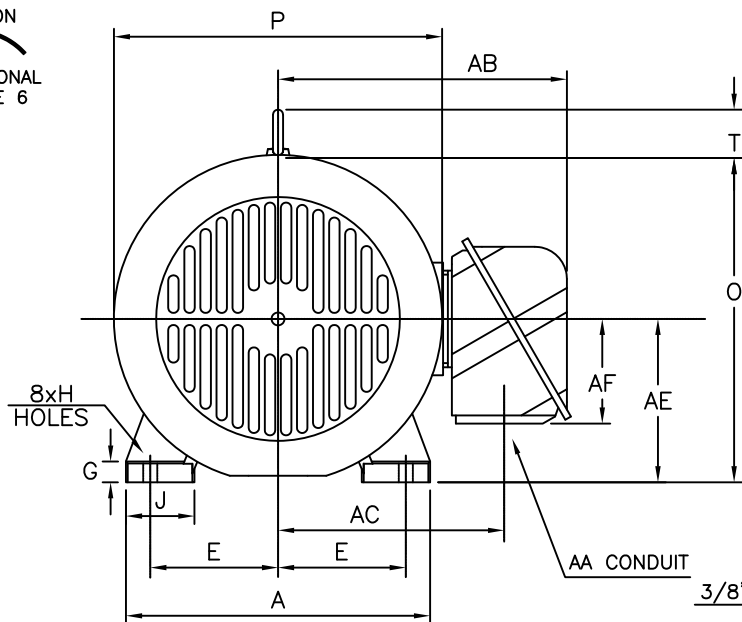

3/8"-16 UNC GND BOLT  
SEE NOTE 7

NOTES:

1. DIMENSION V REPRESENTS LENGTH OF STRAIGHT PART OF SHAFT
2. MAIN CONDUIT BOX MAY BE ROTATED IN 90° INCREMENTS
3. KEY DIMENSIONS EQUAL S x S x 3.88 FOR T AND S x S x 2.00 FOR TS (MOTOR SUPPLIED WITH KEY)
4. MOTOR WEIGHT SHOWN IS MAXIMUM HORSEPOWER IN FRAME
5. THIS DIMENSION EQUALS 2F FOR 324T/TS MOUNTING
6. STANDARD PRODUCT USE BI-DIRECTIONAL FAN. OPPOSITE ROTATION AVAILABLE ONLY BY CONNECTION CHANGE
7. FRAME GROUND BOLT STANDARD ON 841 PRODUCT

UNITS: INCHES

| FRAME SIZE  | MOTOR DIMENSIONS |      |      |      |     |     |   |      |      |      |     | CONDUIT BOX |      |      |      |     |     |     |
|-------------|------------------|------|------|------|-----|-----|---|------|------|------|-----|-------------|------|------|------|-----|-----|-----|
|             | A                | B    | C    | D    | G   | J   | K | M    | O    | P    | T   | AA[NPT]     | AB   | AC   | AE   | AF  | XL  | XN  |
| 324TS/326TS | 14.9             | 15.2 | 29.7 | 8.00 | 0.9 | 3.2 | 0 | 11.1 | 15.9 | 16.1 | 2.4 | 2.00        | 14.3 | 11.1 | 8.00 | 5.1 | 9.1 | 7.7 |
| 324T/326T   | 14.9             | 15.2 | 31.2 | 8.00 | 0.9 | 3.2 | 0 | 11.1 | 15.9 | 16.1 | 2.4 | 2.00        | 14.3 | 11.1 | 8.00 | 5.1 | 9.1 | 7.7 |

| FRAME SIZE  | MOUNTING |             |      |      | SHAFT EXTENSION |      |       | KEY SEAT |       |      | BEARINGS |        | MAXIMUM WEIGHT |
|-------------|----------|-------------|------|------|-----------------|------|-------|----------|-------|------|----------|--------|----------------|
|             | E        | 2F          | H    | BA   | N-W             | V    | U     | R        | S     | ES   | LS       | OS     |                |
| 324TS/326TS | 6.25     | 10.50/12.00 | 0.69 | 5.25 | 3.75            | 3.50 | 1.875 | 1.591    | 0.500 | 2.00 | 6312C3   | 6312C3 | 650 lbs.       |
| 324T/326T   | 6.25     | 10.50/12.00 | 0.69 | 5.25 | 5.25            | 5.00 | 2.125 | 1.845    | 0.500 | 3.88 | 6312C3   | 6312C3 | 650 lbs.       |

CUSTOMER: \_\_\_\_\_ MOTOR MODEL NO.: \_\_\_\_\_  
 P.O. NO.: \_\_\_\_\_ HP: \_\_\_\_\_ VOLTAGE: \_\_\_\_\_ RPM(SYN.): \_\_\_\_\_ Hz: \_\_\_\_\_  
 FRAME SIZE: \_\_\_\_\_ PRODUCT TYPE: EQP III 840 & 841  
 COMMENTS: \_\_\_\_\_  
 \_\_\_\_\_  
 PER: \_\_\_\_\_ DATE: \_\_\_\_\_

TAG NO's.:

.....  
 .....  
 .....  
 .....  
 .....  
 .....

|                                     |                          |
|-------------------------------------|--------------------------|
| <input checked="" type="checkbox"/> | STANDARD (NO AUX. BOXES) |
| <input type="checkbox"/>            | RTD AUX. BOX             |
| <input type="checkbox"/>            | SPACE HEATER AUX. BOX    |
| <input type="checkbox"/>            | BEARING RTD's            |

TOSHIBA RESERVES THE RIGHT TO MAKE CHANGES OF TECHNICAL IMPROVEMENT AND THE DATA MAY CHANGE WITHOUT NOTICE  PRELIMINARY

DO NOT USE FOR CONSTRUCTION, INSTALLATION, OR APPLICATION PURPOSES UNLESS THE DRAWING IS MARKED AS CERTIFIED  CERTIFIED

**TOSHIBA**

TOSHIBA INTERNATIONAL CORPORATION

TOTALLY-ENCLOSED FAN-COOLED  
HORIZONTAL FOOT-MOUNTED  
3 PHASE INDUCTION MOTOR  
F1 ASSEMBLY

**XT SERIES**

VISIT OUR WEBSITE AT:  
www.toshiba.com/ind

**TYPICAL MOTOR PERFORMANCE DATA**

Model: B0404FLF3BSHJ01

| HP        | kW | Pole       | FL RPM | Frame | Voltage        | Hz          | Phase    | FL Amps      |
|-----------|----|------------|--------|-------|----------------|-------------|----------|--------------|
| 40        | 30 | 4          | 1770   | 324T  | 460            | 60          | 3        | 47           |
| Enclosure | IP | Ins. Class | S.F.   | Duty  | NEMA Nom. Eff. | NEMA Design | kVA Code | Ambient (°C) |
| TEFC      | 55 | F          | 1.15   | CONT  | 94.1           | B           | G        | 40 C         |

| Load         | HP    | kW   | Amperes | Efficiency (%) | Power Factor (%) |
|--------------|-------|------|---------|----------------|------------------|
| Full Load    | 40    | 29.8 | 47.0    | 94.1           | 84.5             |
| ¾ Load       | 30.00 | 22.4 | 36.5    | 94.5           | 82.0             |
| ½ Load       | 20.00 | 14.9 | 27.2    | 94.2           | 75.0             |
| ¼ Load       | 10.00 | 7.5  | 19.9    | 85.9           | 54.8             |
| No Load      |       |      | 15.0    |                | 5.0              |
| Locked Rotor |       |      | 290.00  |                | 46.3             |

| Torque               |                         |                    |                       | Rotor wk <sup>2</sup><br>Inertia<br>(lb-ft <sup>2</sup> ) |
|----------------------|-------------------------|--------------------|-----------------------|---|
| Full Load<br>(lb-ft) | Locked Rotor<br>(% FLT) | Pull Up<br>(% FLT) | Break Down<br>(% FLT) |   |
| 119                  | 290                     | 255                | 255                   | 7.92  |

| Safe Stall Time(s) |     | Sound Pressure<br>dB(A) @ 1M | Bearings* |        | Approx. Motor Weight<br>(lbs) |
|--------------------|-----|------------------------------|-----------|--------|-------------------------------|
| Cold               | Hot |                              | DE        | NDE    |                               |
| 24                 | 15  | -                            | 6312C3TMB | 6312C3 |                               |

\*Bearings are the only recommended spare part(s).

**Motor Options:**  
Product Family:EQPIII 841  
Mounting:Footed,Shaft:T Shaft

|             |  |
|-------------|--|
| Customer    |  |
| Customer PO |  |
| Sales Order |  |
| Project #   |  |

Tag:

All characteristics are average expected values.

**TOSHIBA INTERNATIONAL CORPORATION · HOUSTON, TEXAS U.S.A.**

|             |          |                  |             |             |               |
|-------------|----------|------------------|-------------|-------------|---------------|
| Engineering | gminetos | Doc. Written By  | D. Suarez   | Doc.# / Rev | MPCF-1119 / 0 |
| Engr. Date  | 7/8/2013 | Doc. Approved By | M. Campbell | Doc. Issued | 6/8/2011      |

**SPEED TORQUE/CURRENT CURVE**

Model: B0404FLF3BSHJ01

|                   |   |                   |                  |             |                |             |          |                |
|-------------------|---|-------------------|------------------|-------------|----------------|-------------|----------|----------------|
| HP                | kW  | Pole              | FL RPM           | Frame       | Voltage        | Hz          | Phase    | FL Amps        |
| 40                | 30  | 4                 | 1770             | 324T        | 460            | 60          | 3        | 47             |
| Enclosure         | IP  | Ins. Class        | S.F.             | Duty        | NEMA Nom. Eff. | NEMA Design | kVA Code | Ambient (°C)   |
| TEFC              | 55  | F                 | 1.15             | CONT        | 94.1           | B           | G        | 40 C           |
| Locked Rotor Amps | Rotor wk <sup>2</sup> Inertia (lb-ft <sup>2</sup> ) | Torque            |                  |             |                |             |          | Break Down (%) |
|                   |   | Full Load (lb-ft) | Locked Rotor (%) | Pull Up (%) |                |             |          |                |
| 290.00            | 7.92  | 119               | 290              | 255         |                |             | 255      |                |

**Design Values**

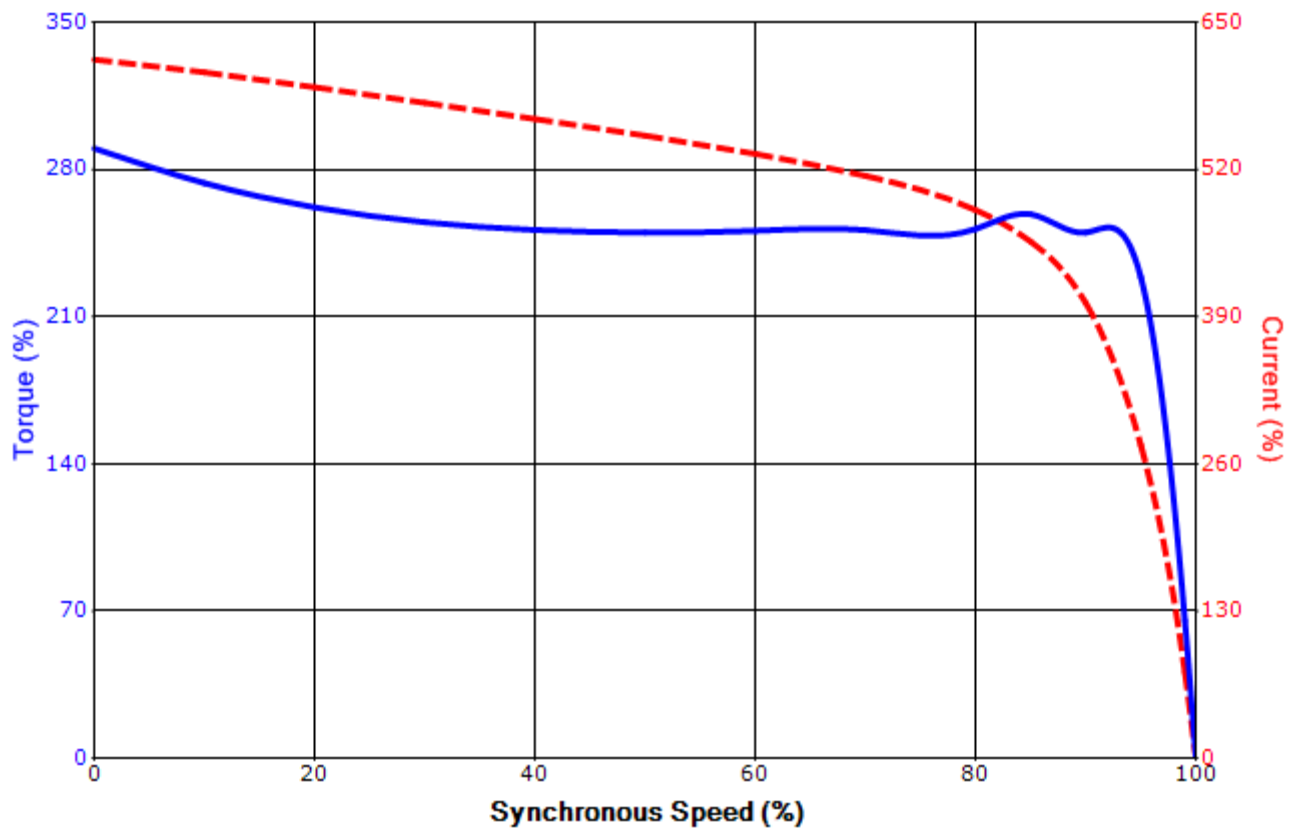

|             |  |  |     |
|-------------|--|--|-----|
| Customer    |  | wk <sup>2</sup> Load Inertia (lb-ft <sup>2</sup> ) | -   |
| Customer PO |  | Load Type  | -   |
| Sales Order |  | Voltage (%)  | 100 |
| Project #   |  | Accel. Time  | -   |

Tag:

All characteristics are average expected values.

**TOSHIBA INTERNATIONAL CORPORATION · HOUSTON, TEXAS U.S.A.**

|             |          |                  |             |             |               |
|-------------|----------|------------------|-------------|-------------|---------------|
| Engineering | gminetos | Doc. Written By  | D. Suarez   | Doc.# / Rev | MPCF-1121 / 0 |
| Engr. Date  | 7/8/2013 | Doc. Approved By | M. Campbell | Doc. Issued | 6/8/2011      |

**Motor Connection Diagram**  
3 Leads - Delta Connection



Switch L1 and L2 to reverse rotation

Each lead may consist of more than one cable.  
If multiple cables represent a single lead, each one  
of them will be labeled with the appropriate lead number.