

INDEX	MDSL0051-13
REV. LEVEL	4
SHEET	1 OF 1

TOSHIBA/HOUSTON DRIP-PROOF HORIZONTAL FOOT-MOUNTED

Fr. 449
DIRECT COUPLE
2 POLE

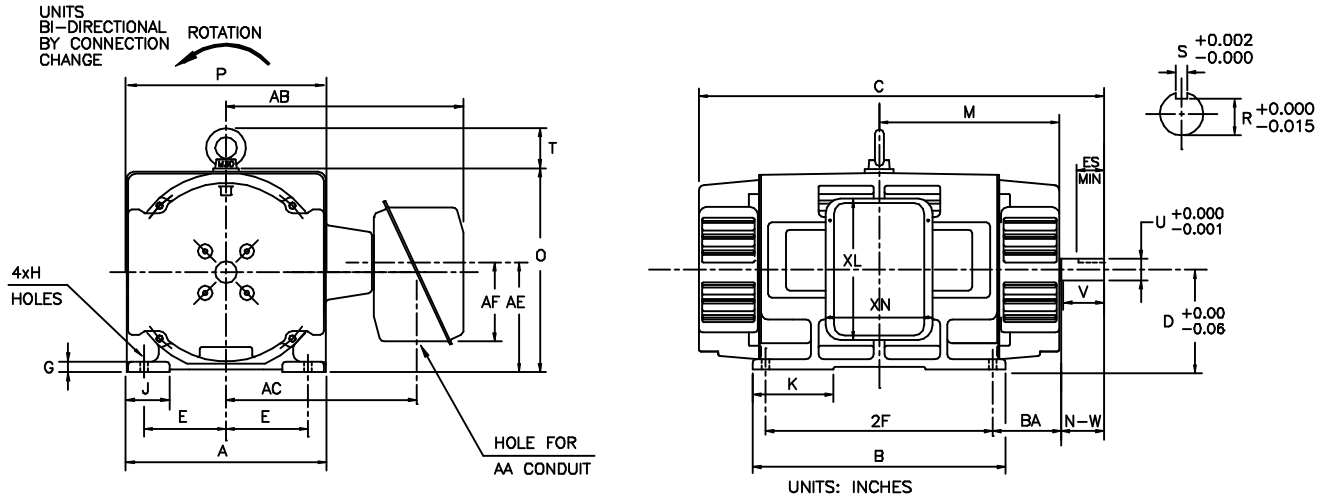

FRAME SIZE	MOUNTING				CONDUIT BOX						
	E	2F	H	BA	AA	AB	AC	AE	AF	XL	XN
449TS	9.00	25.00	0.81	7.50	3.0	26.0	21.3	12.05	8.7	15.50	11.7

FRAME SIZE	MOTOR DIMENSIONS										
	A	B	C	D	G	J	K	M	O	P	T
449TS	22.0	27.8	44.75	11.00	1.16	4.53	8.86	20.0	22.44	22.0	4.33

FRAME SIZE	SHAFT EXTENSION			KEY SEAT			BEARINGS		MAXIMUM WEIGHT
	N-W	V	U	R	S	ES	LS	OS	
449TS	4.75	4.50	2.375	2.021	.625	3.03	6313C3	6313C3	2575 lbs.

- NOTES:
1. DIMENSION V REPRESENTS LENGTH OF STRAIGHT PART OF SHAFT
 2. CONDUIT BOX WILL BE MOUNTED ON OPPOSITE SIDE UPON REQUEST. CONDUIT BOX MAY BE ROTATED IN 90° INCREMENTS
 3. KEY DIMENSIONS EQUAL S x S x 3.00 (MOTOR SUPPLIED WITH KEY)
 4. MOTOR WEIGHT SHOWN IS MAXIMUM HORSEPOWER IN FRAME.

ALL DATA SUBJECT TO CHANGE WITHOUT NOTICE.
FOR CONSTRUCTION USE ONLY CERTIFIED DATA.

CERTIFIED DATA

CUSTOMER: _____ P.O. NO.: _____ TAG NO.: _____
MOTOR MODEL NO.: _____ TOSHIBA FILE NO.: _____
HP: _____ RPM (SYN.): _____ VOLTAGE: _____ Hz: _____
FRAME SIZE: _____ LOG NO.: _____ LOG REV. LEVEL: _____
REMARKS: _____
PER: _____ ISSUE DATE: _____ SUPERSEDES: _____

TYPICAL MOTOR PERFORMANCE DATA

Model: B6002VKG3BME

HP	kW	Pole	FL RPM	Frame	Voltage	Hz	Phase	FL Amps
600	447	2	3570	449TS	460	60	3	665
Enclosure	IP	Ins. Class	S.F.	Duty	NEMA Nom. Eff.	NEMA Design	kVA Code	Ambient (°C)
ODP	12	F	1.0	CONT	94.1	-	F	40 C

Load	HP	kW	Amperes	Efficiency (%)	Power Factor (%)
Full Load	600	447.4	665.0	94.3	89.0
¾ Load	450.00	335.6	495.2	94.2	86.0
½ Load	300.00	223.7	349.5	92.8	78.3
¼ Load	150.00	111.9	221.3	90.1	70.4
No Load			132.0		8.2
Locked Rotor			4070.00		26.1

Torque				Rotor wk ²
Full Load (lb-ft)	Locked Rotor (% FLT)	Pull Up (% FLT)	Break Down (% FLT)	Inertia (lb-ft ²)
883	140	130	210	80.04

Safe Stall Time(s)		Sound Pressure dB(A) @ 1M	Bearings*		Approx. Motor Weight (lbs)
Cold	Hot		DE	NDE	
8.3	4.7	-	6313C3	6313C3	

*Bearings are the only recommended spare part(s).

Motor Options:
Product Family:ODP
Mounting:Footed,Shaft:TS Shaft

Customer	
Customer PO	
Sales Order	
Project #	

Tag:

All characteristics are average expected values.

TOSHIBA INTERNATIONAL CORPORATION · HOUSTON, TEXAS U.S.A.

Engineering	bammen	Doc. Written By	D. Suarez	Doc.# / Rev	MPCF-1119 / 0
Engr. Date	5/13/2014	Doc. Approved By	M. Campbell	Doc. Issued	6/8/2011

SPEED TORQUE/CURRENT CURVE

Model: B6002VKG3BME

HP	kW	Pole	FL RPM	Frame	Voltage	Hz	Phase	FL Amps
600	447	2	3570	449TS	460	60	3	665
Enclosure	IP	Ins. Class	S.F.	Duty	NEMA Nom. Eff.	NEMA Design	kVA Code	Ambient (°C)
ODP	12	F	1.0	CONT	94.1	-	F	40 C
Locked Rotor Amps	Rotor wk ² Inertia (lb-ft ²)	Torque						Break Down (%)
		Full Load (lb-ft)	Locked Rotor (%)	Pull Up (%)				
4070.00	80.04	883	140	130			210	

Design Values

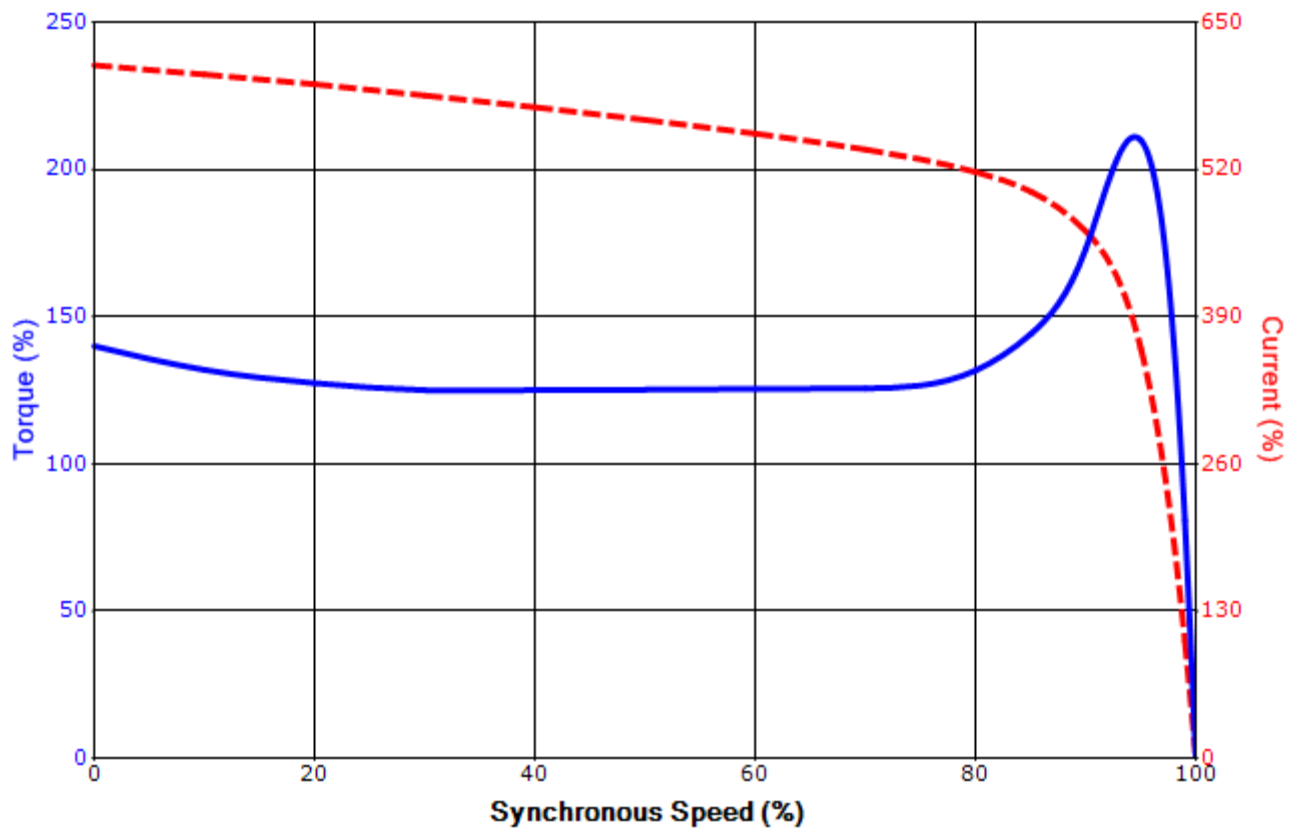

Customer		wk ² Load Inertia (lb-ft ²)	-
Customer PO		Load Type	-
Sales Order		Voltage (%)	100
Project #		Accel. Time	-

Tag:

All characteristics are average expected values.

TOSHIBA INTERNATIONAL CORPORATION · HOUSTON, TEXAS U.S.A.

Engineering	bmammen	Doc. Written By	D. Suarez	Doc.# / Rev	MPCF-1121 / 0
Engr. Date	5/13/2014	Doc. Approved By	M. Campbell	Doc. Issued	6/8/2011

Motor Connection Diagram

12 Leads

Single Voltage

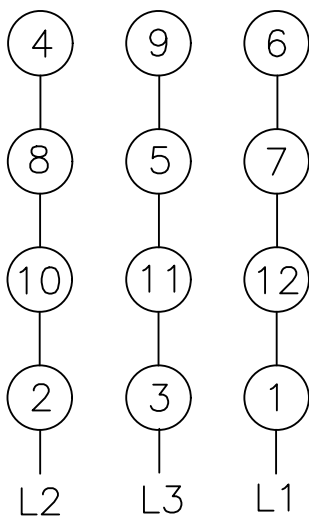
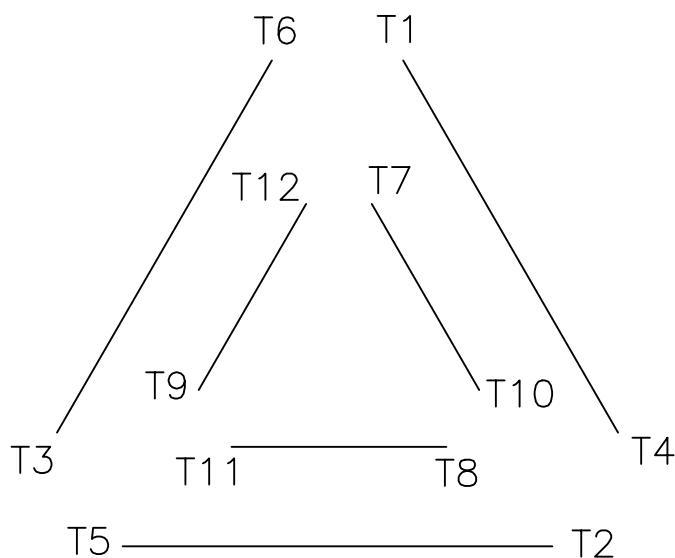

Switch L1 and L2 to reverse rotation