

DUTY MASTER ALTERNATING CURRENT MOTORS

SQUIRREL-CAGE INDUCTION
CAST IRON CONSTRUCTION

ENCLOSURE: TOTALLY ENCLOSED
MOUNTING: FOOT, NEMA "C" FACE

FRAMES 364TSC-365TSC
841-XL WITH STANDARD OVERSIZED CONDUIT BOX

COOLING: FAN COOLED

617428-009

D

C

B

A

D

C

B

A

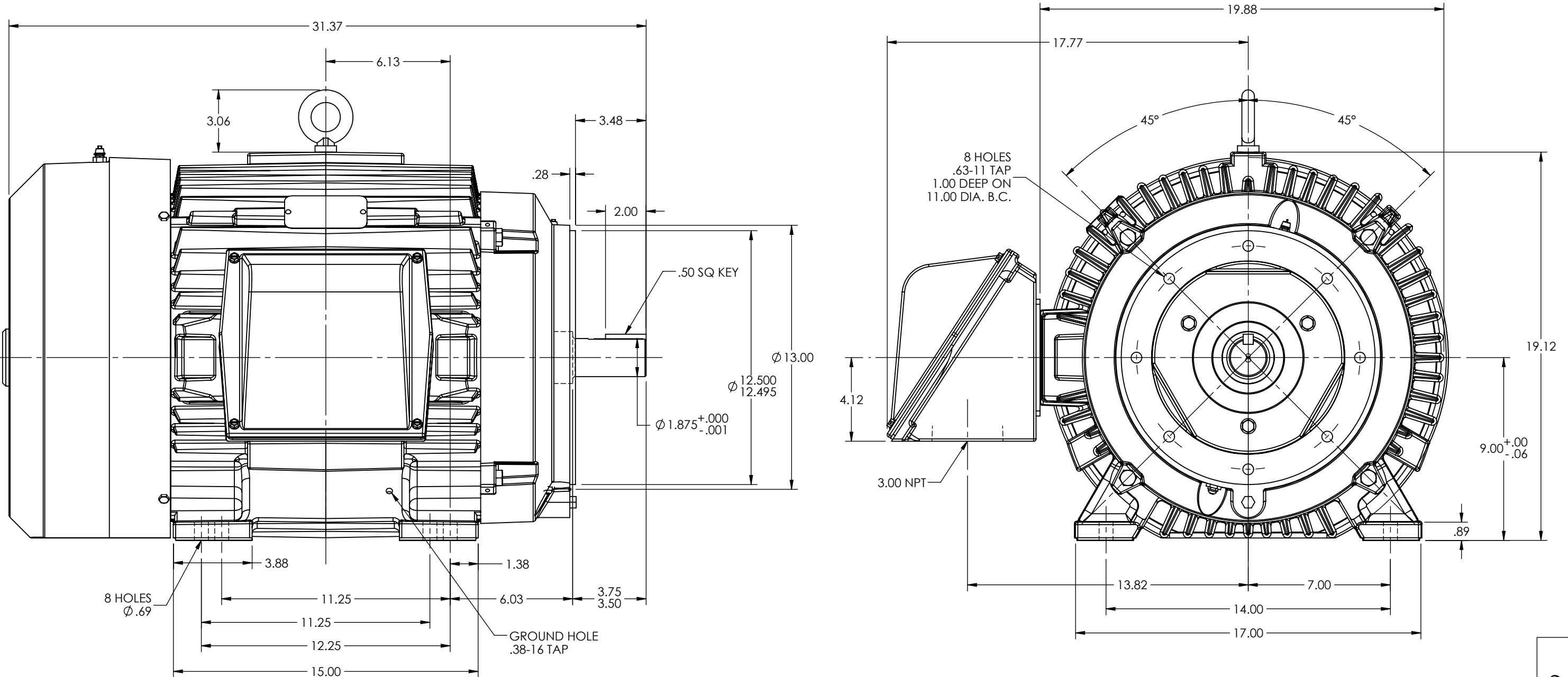

CUSTOMER IS RESPONSIBLE FOR DETERMINING THAT BALDOR'S PRODUCT WILL PERFORM SUITABLY IN THE INTENDED APPLICATION

WEIGHT (LBS): 364TSC = 874
365TSC = 899
MOTOR WEIGHTS MAY VARY BY 15% DEPENDING UPON RATING.

| | | | |
|--------------------------------|-------------|------------------------------|-------------------|
| REV. DESC: NEW FROM 611760-571 | | | |
| REV: - | VERSION: 00 | REVISED: 02:51:17 03/27/2013 | TDR: 000000792424 |
| MODEL NO. 617428-009 | | | REF: |
| BY: ENBUFC0 | | | B |

BALDOR

DIM SHT TEFC 364-365TSC C FACE 841-XL W/ STD C BOX FT MTG

617428-009

8 7 6 5 4 3 2 1