

# DUTY MASTER ALTERNATING CURRENT MOTORS

SQUIRREL-CAGE INDUCTION  
CAST IRON CONSTRUCTION

ENCLOSURE: TOTALLY ENCLOSED  
MOUNTING: FOOT, NEMA "C" FACE

FRAMES 364TC-365TC  
841-XL WITH STANDARD OVERSIZED CONDUIT BOX

COOLING: FAN COOLED

617428-010

D

C

B

A

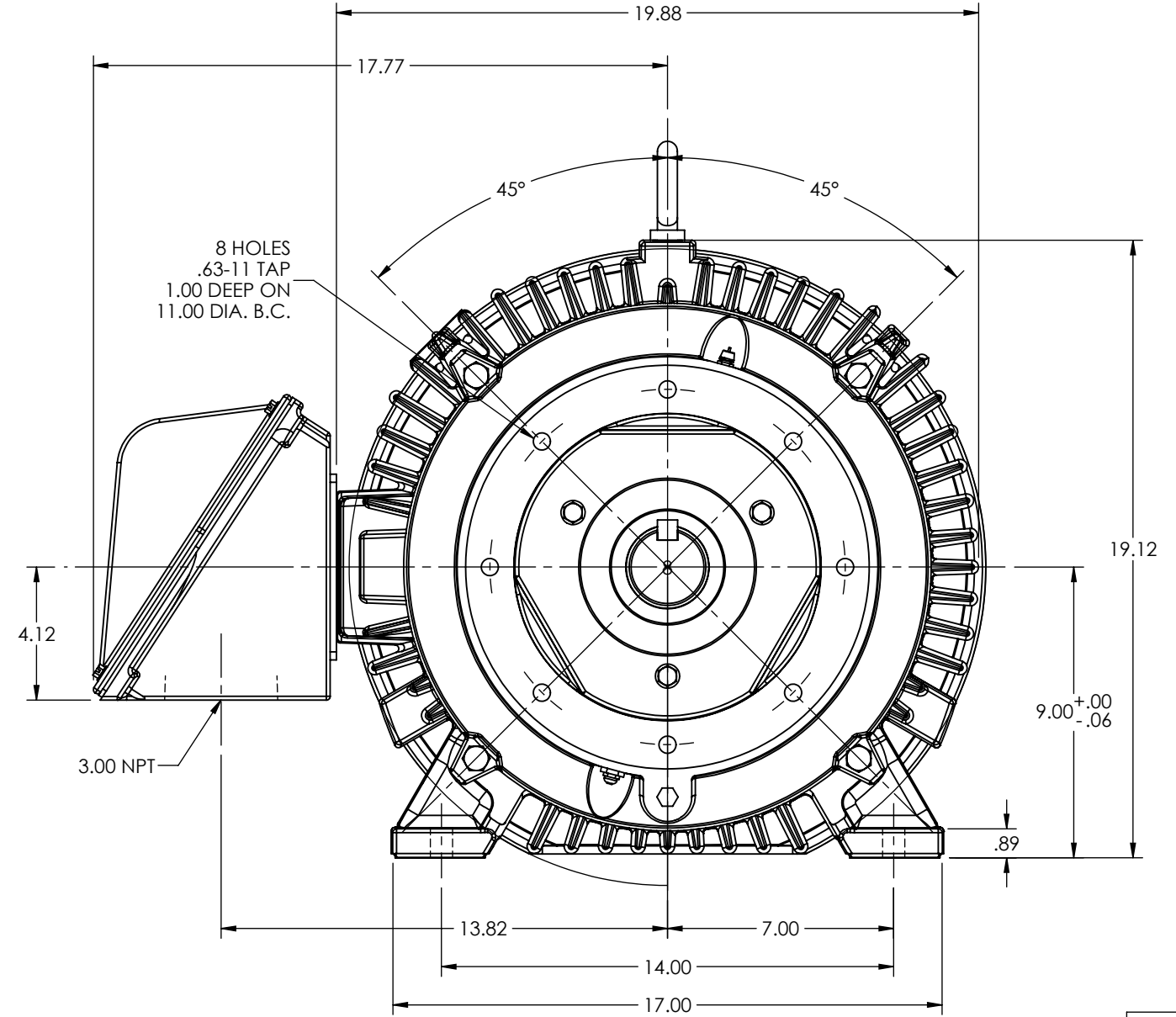
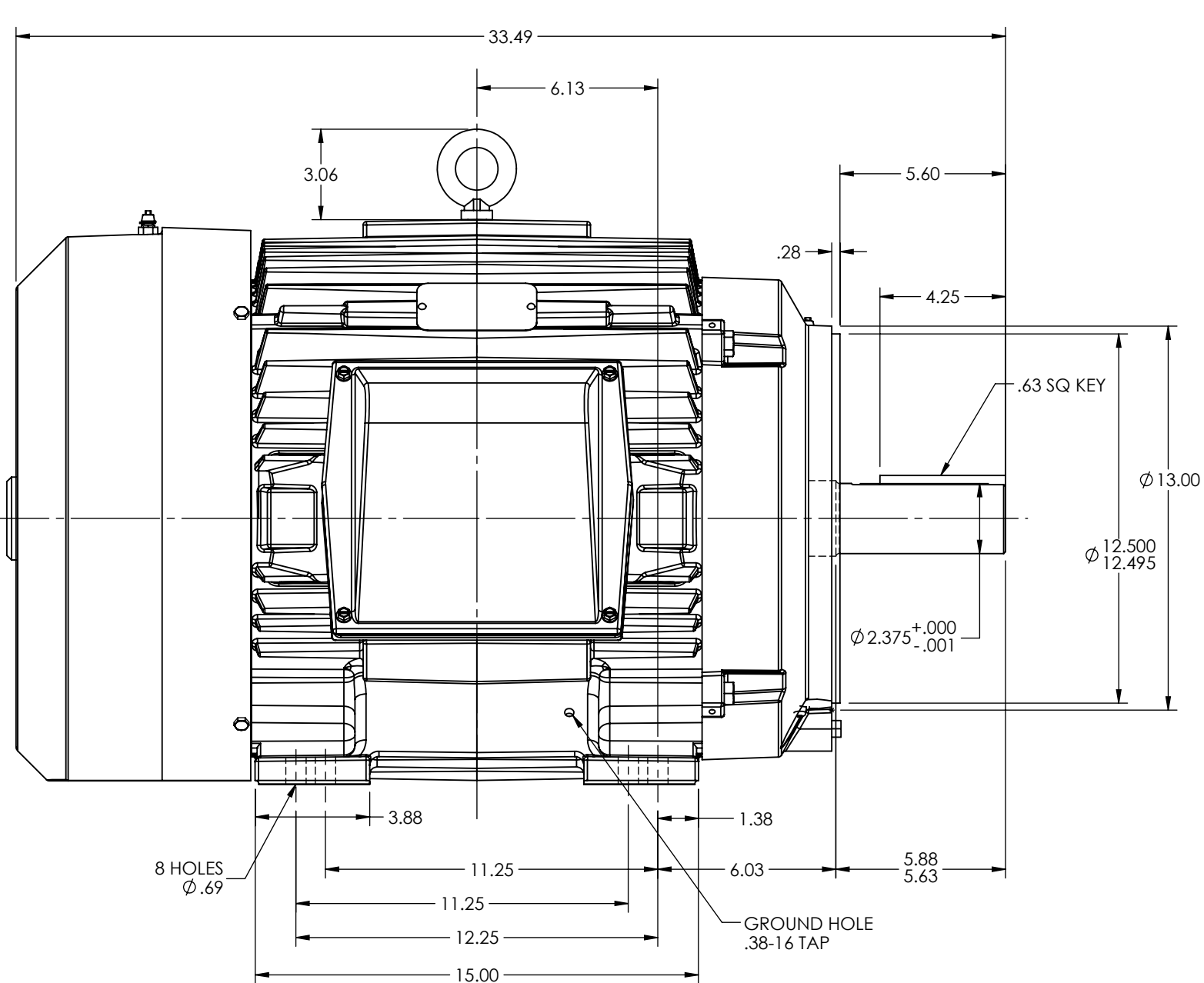

D

C

B

A

617428-010

WEIGHT (LBS): 364TC = 880  
365TSC = 905  
MOTOR WEIGHTS MAY VARY BY 15% DEPENDING UPON RATING.

REV. DESC: NEW FROM 611760-571			
REV: -	VERSION: 00	REVISED: 03:18:26 03/27/2013	TDR: 000000792489
MODEL NO. 617428-010			REF:
BY: ENBUFC0			<b>B</b>

CUSTOMER IS RESPONSIBLE FOR DETERMINING THAT BALDOR'S PRODUCT WILL PERFORM SUITABLY IN THE INTENDED APPLICATION

## BALDOR

DIM SHT TEFC 364-365TC C FACE 841-XL W/ STD C BOX FT MTG

8 7 6 5 4 3 2 1