

FRONT END DETAIL

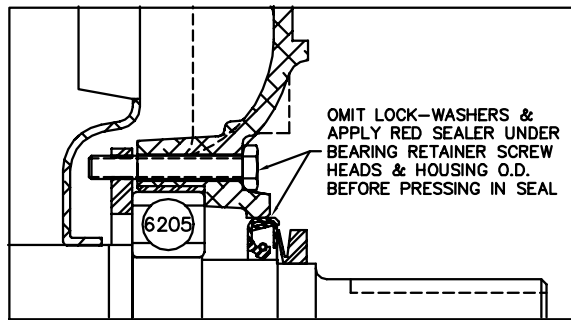

PULLEY END DETAIL

CUSTOMER IS RESPONSIBLE FOR DETERMINING THAT MOTOR PERFORMANCE IS SUITABLE IN THE APPLICATION.

REV. DESC: CORRECT DESCRIPTION		
REV. LTR: B	VERSION: 02	TDR: 000000428012
FILE: \AAA\00092\923	REVISED: 11:35:09 04/11/2007	BY: ENBRAMO
MTL: -		

**BALDOR ELECTRIC Co.**

STD HORZ 56C TEFC 35M WD (S/P #9)