

FRONT END DETAIL

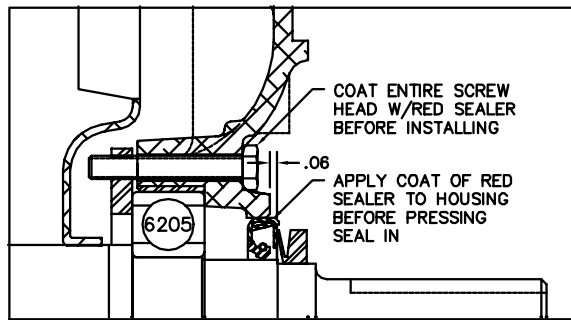

PULLEY END DETAIL

CUSTOMER IS RESPONSIBLE FOR DETERMINING THAT MOTOR PERFORMANCE IS SUITABLE IN THE APPLICATION.

REV. DESC: ADDED DRAIN PLUGS	VERSION: 01	TDR: 000000373915
REV. LTR: R	REVISD: 08:30:25 08/25/2005	BY: ENKENTO
FILE: \AAA\00012\635	MTL: -	

BALDOR ELECTRIC Co.

STD 56C TEFC HORZ 35M - HOSE DOWN (SP 9)