

1 X ϕ .88 KNOCKOUT (PU. END)
 2 X ϕ .88 KNOCKOUTS (FR. END)

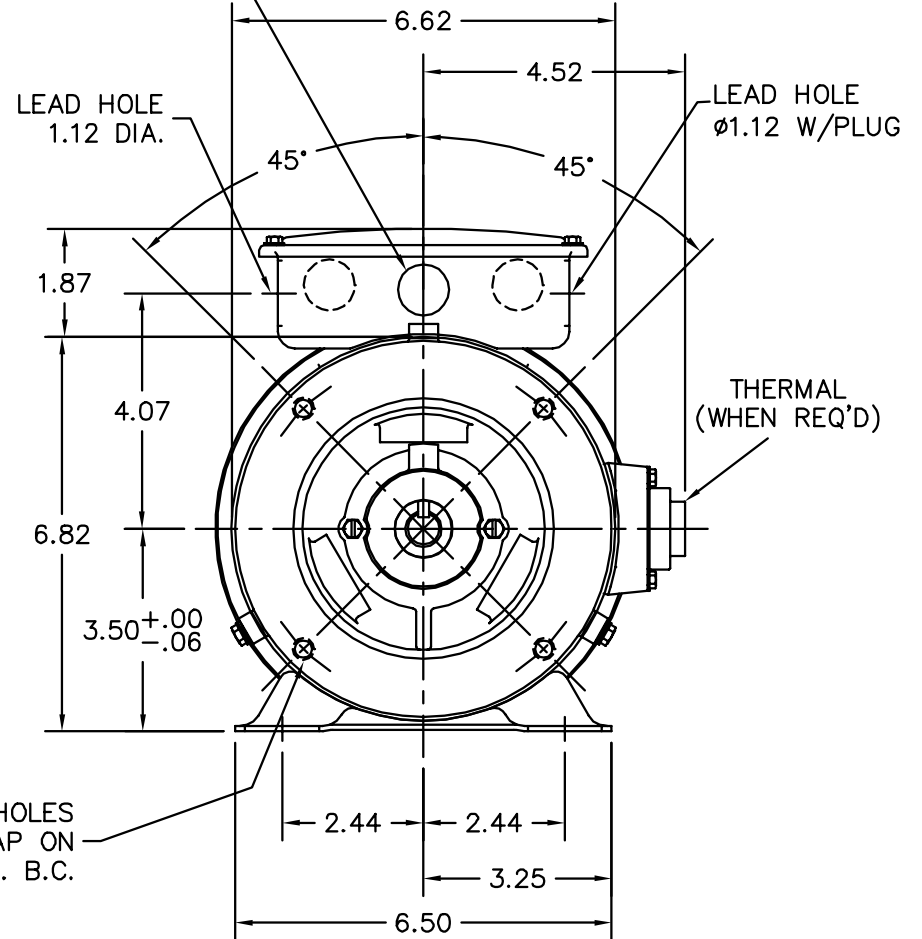
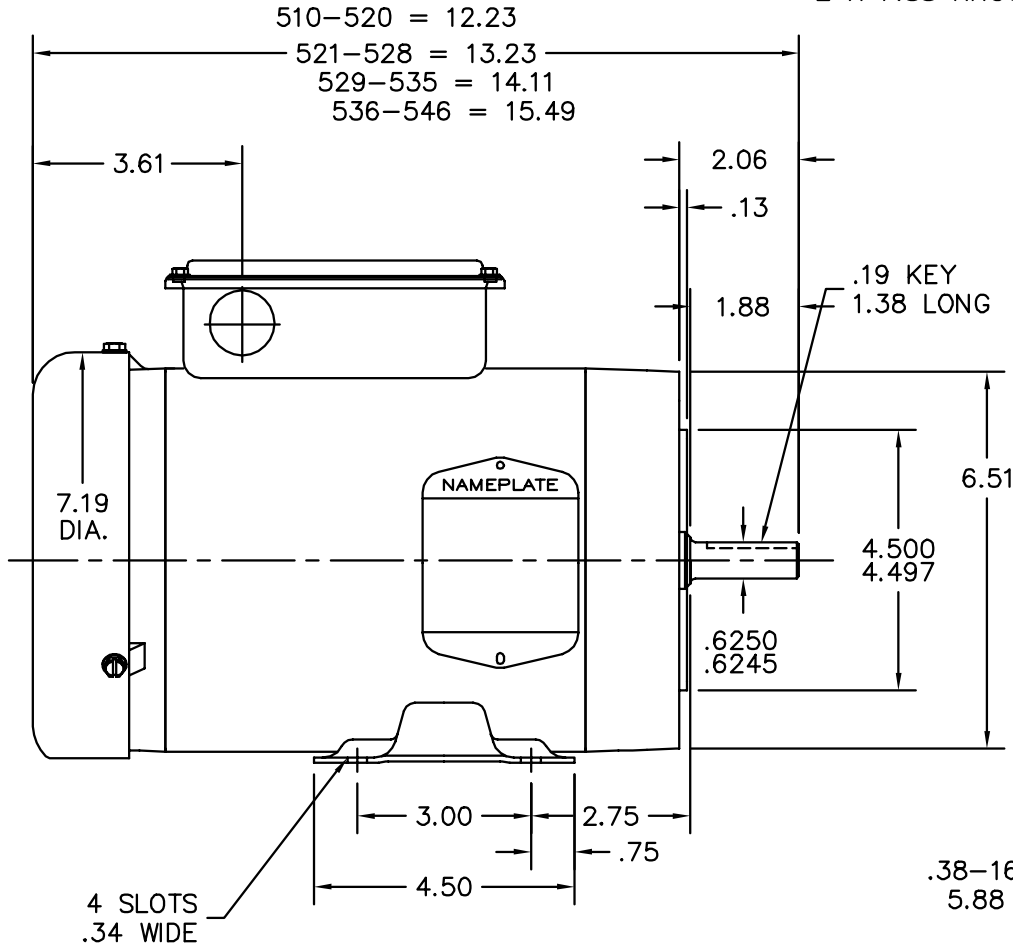

CUSTOMER IS RESPONSIBLE FOR DETERMINING THAT MOTOR PERFORMANCE IS SUITABLE IN THE APPLICATION.

REV. DESC: NEW		
REV. LTR: -	VERSION: 00	TDR: 000000448470
35LYX046	FILE: \AAA\00152\645	REVISED: 15: 24: 47 12/03/2007
	MTL: - BY: ENALEMO	

BALDOR • DODGE • RELIANCE

HORZ 56C TEFC M F3 W/35CB4007