

ATENÇÃO/ATTENTION
 MOTOR DEVE SER LIGADO APENAS NA POSIÇÃO VERTICAL
 MOTOR MUST BE ENERGIZED ONLY IN THE VERTICAL POSITION

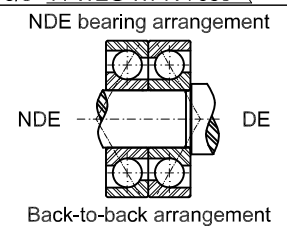
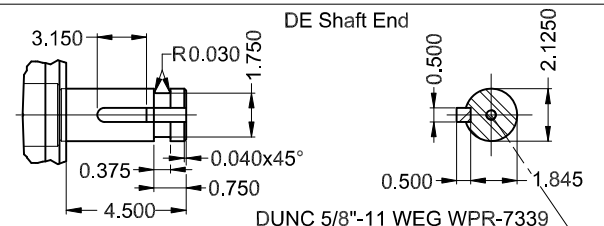
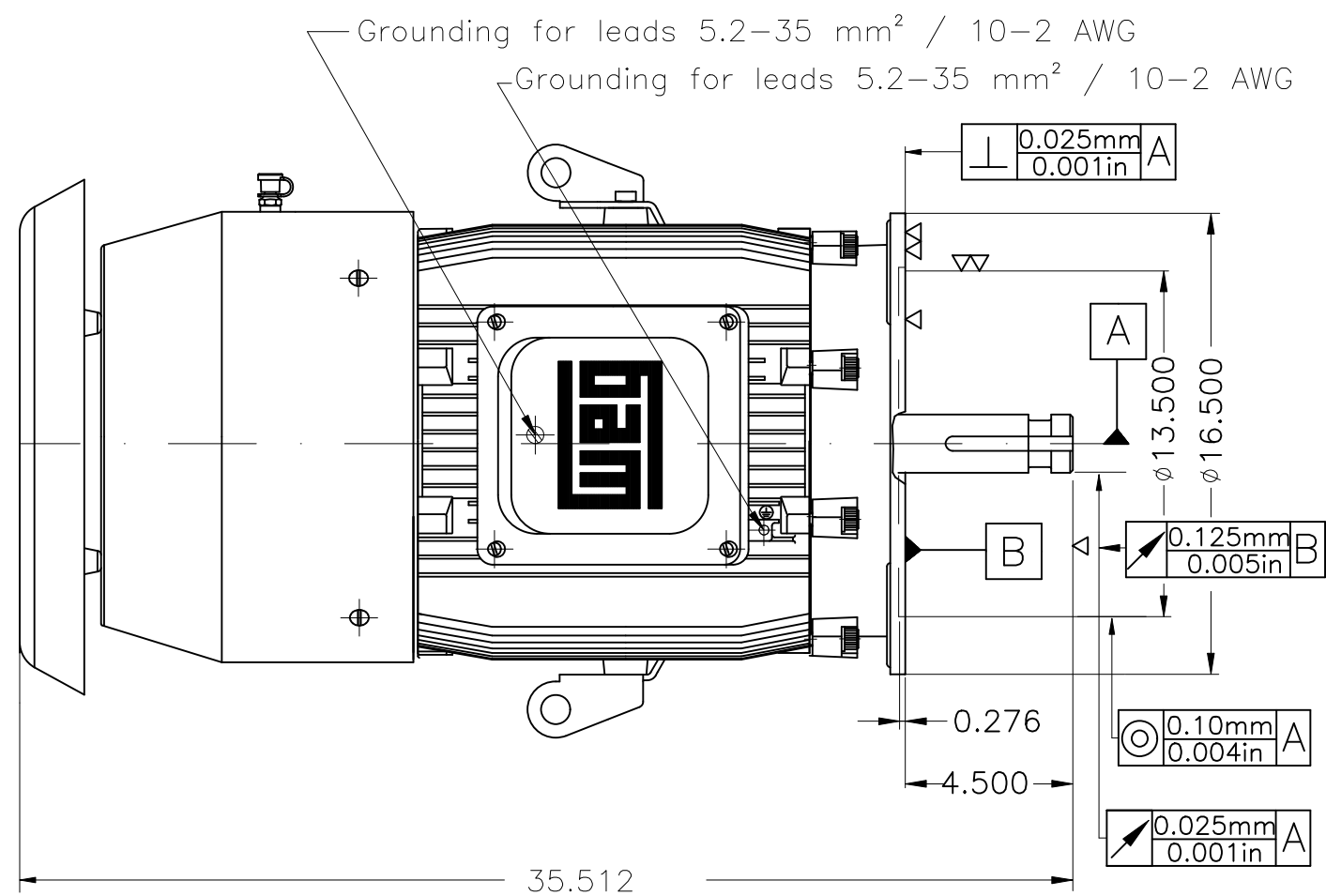
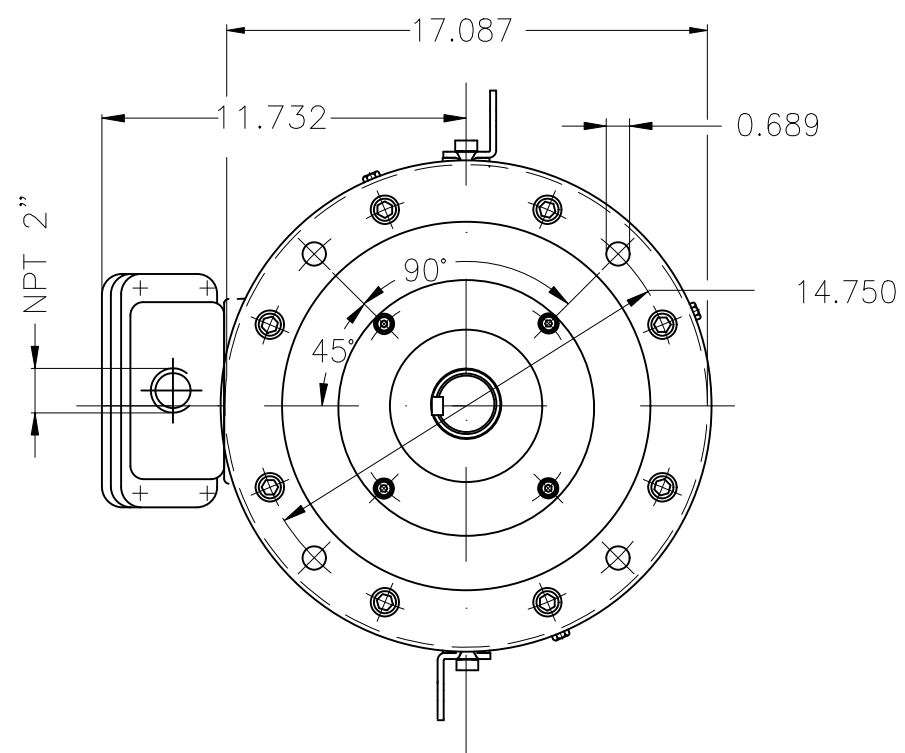

- Design B
- Type "T" threaded drain plug
- Stainless Steel Grease fitting
- Tropicalized internal painting according to IEEE841
- Rotation CW and CCW
- Grease outlet according to IEEE841
- Certification CSA/UL
- Sealing - INPRO/SEAL
- Tirrol oil applied on endshields fittings
- Color RAL 5009
- Painting plan 202E
- Mounting NEMA W-6
- Mounting V1

		Bearing		Lubricant	
DE		6212		MOBIL POLYREX EM	
NDE		7310BECB		MOBIL POLYREX EM	

40 HP 02 Poles 60 Hz A

ECM	LOC	SUMMARY OF MODIFICATIONS			EXECUTED	CHECKED	RELEASED	DATE	VER
EXECUTED	ARLETEDF	THREE PH. MOTOR IN LINE EXTRA THRUST NEMA PREM. EFF.							
CHECKED	GUILHERMEMC	FRAME 324LP IP55 TEFC							
RELEASED	GUILHERMEMC								
REL. DATE	07.11.2024	WMO	JARAGUA DO SUL	[Engenharia de Produto]					

1611434473
 WDD 03

PRELIMINARY DOCUMENT - Not to be used for installation purposes. Dimensions in inches XME A3