

DUTY MASTER ALTERNATING CURRENT MOTORS

ENCLOSURE: TOTALLY ENCLOSED
 MOUNTING: FOOT
 SQUIRREL-CAGE INDUCTION
 CAST IRON CONSTRUCTION
 FRAMES 250T THRU 440TS
 661-XL WITH STANDARD CONDUIT BOX
 COOLING: FAN COOLED

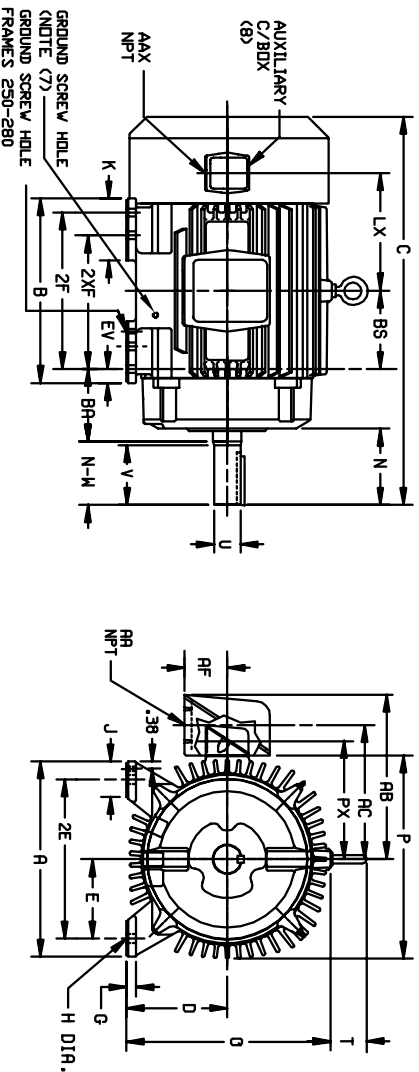

DIMENSIONS ARE IN INCHES. SEE SHEET 2 FOR DIMENSIONS IN MILLIMETERS

FRAME	A	Dx2	E	G	H	J	K	D	P	T	CAST IRON TERMINAL BOX						AUX C/BOX (8)		
											AA	AB	AC	AD	AE	EV	AAx	Lx	Px
254T-296T	12.50	6.25	5.00	.75	.56	2.50	---	13.25	13.25	2.44	1-1/4	10.81	8.81	2.50	4.25	1.00	3/4	7.06	9.31
284T-286TS	13.75	7.00	5.50	.75	.56	2.50	---	14.75	14.88	2.44	1-1/2	12.62	10.19	3.00	4.75	1.00	3/4	7.63	10.50
324T-326TS	15.50	8.00	6.25	.88	.69	2.75	4.50	16.69	17.00	2.44	2	15.44	11.69	3.62	5.25	1.38	3/4	8.75	10.50
364T-365TS	17.00	9.00	7.00	.88	.69	2.75	3.88	18.50	19.50	2.94	3	18.00	13.81	4.12	5.88	1.38	3/4	9.12	11.62
404T-405TS	19.00	10.00	8.00	1.12	.81	3.25	4.62	21.31	22.50	2.94	3	19.25	15.06	4.12	6.62	1.13	3/4	9.62	14.44
444T-445TS	21.00	11.00	9.00	1.12	.81	3.25	5.25	23.98	25.25	3.25	3	22.19	17.44	6.00	7.50	1.25	3/4	11.12	15.25

FRAME	C	BS	B	2F	(4)	N	N-V(6)	SHAFT AND KEY			WEIGHT	
SIZE								U(3)	V	SG.	LGTH.	LBS. (3)
254T	24.56	5.00	12.00	---	8.25	4.12	4.00	1.625	3/75	3.75	2.88	3.35
256T	24.56	5.00	12.00	10.00	---	4.12	4.00	1.625	3/75	3.75	2.88	3.45
284T	27.44	5.50	13.00	---	9.50	5.00	4.62	1.875	4.38	5.00	3.25	4.75
284TS	26.06	5.50	13.00	---	9.50	3.62	3.25	1.625	3.00	3.75	1.88	4.75
286T	27.44	5.50	13.00	11.00	---	5.00	4.62	1.875	4.38	5.00	3.25	4.90
286TS	26.06	5.50	13.00	11.00	---	3.62	3.25	1.625	3.00	3.75	1.88	4.90
324T	30.44	6.00	14.75	---	10.50	5.62	5.25	2.125	5.00	3.98	5.90	5.90
324TS	28.94	6.00	14.75	---	10.50	4.12	3.75	1.875	3.50	5.00	2.00	6.30
326T	30.44	6.00	14.75	12.00	---	5.62	5.25	2.125	5.00	5.00	3.88	6.30
326TS	28.94	6.00	14.75	12.00	---	4.12	3.75	1.875	3.50	5.00	2.00	6.30
364T	33.44	6.12	15.00	---	11.25	6.25	5.88	2.375	5.62	6.25	4.25	8.65
364TS	31.31	6.12	15.00	---	11.25	4.12	3.75	1.875	3.50	5.00	2.00	8.90
365TS	33.44	6.12	15.00	12.25	---	6.25	5.88	2.375	5.62	6.25	4.25	8.90
404T	36.31	6.88	16.00	---	12.25	7.50	7.25	2.875	7.00	7.50	5.62	12.20
404TS	35.31	6.88	16.00	---	12.25	4.50	4.25	2.125	4.00	5.00	2.75	12.11
405T	38.31	6.88	16.00	13.75	---	7.50	7.25	2.875	7.00	7.50	5.62	12.60
405TS	36.31	6.88	16.00	13.75	---	4.50	4.25	2.125	4.00	5.00	2.75	12.51
444T	44.62	8.25	19.00	---	14.50	8.94	8.50	3.375	8.25	8.75	6.88	16.70
444TS	40.88	8.25	19.00	---	14.50	5.19	4.75	2.375	4.50	6.25	3.00	16.54
445T	44.62	8.25	19.00	16.50	---	8.94	8.50	3.375	8.25	8.75	6.88	16.60
445TS	40.88	8.25	19.00	16.50	---	5.19	4.75	2.375	4.50	6.25	3.00	16.44

- (1) SPECIAL DIMENSIONS APPLYING TO THIS ORDER ON THIS LINE.
 - (2) 'D' VARIES — 250T - 320T +.00, -.03
 — 360T - 440T +.00, -.06
 - (3) 'U' VARIES — UP TO 1.625 DIA. +.0000, -.0005
 — 1.625 AND LARGER +.000, -.001.
 - (4) ALL FRAMES HAVE EIGHT MOUNTING HOLES FOR DUAL MOUNTING.
 - (5) MOTOR WEIGHTS MAY VARY BY 15% DEPENDING UPON RATING.
 - (6) 'N-V' VARIES +.00, -.25.
 - (7) GROUND SCREW HOLE 3/8-16 TAP 1 TO 200 HP ABOVE 200 HP 1/2-13
 - (8) AUXILIARY CONDUIT BOX SUPPLIED ONLY WHEN REQUESTED
- FRAME- _____ TYPE- _____ CERTIFIED FOR- _____
 ORDER- _____ ITEM- _____ HP- _____ RPM- _____ PH- _____ HZ _____ VOLTS _____
 SALES ORDER- _____ APPROVED BY- _____ DATE _____

CUSTOMER IS RESPONSIBLE FOR DETERMINING THAT BALDOR'S PRODUCT WILL PERFORM SUITABLY IN THE INTENDED APPLICATION.

REV. DESC: LOADED TO BUS	VERSION: 01	TDR: 000000547216
REV. LTR: A	REVISED: 03:38:56 06/25/2010	BY: RAGHZT
FILE: \RAG\00009\654		
MTL: -		



DIM SHEET—TEFC 250T-440TS,661-XL W/ STD C/BOX
 SH 1 of 1