

CUSTOMER ONLY NOTE: FOR VERTICAL
SHAFT UP LIFTING, REMOVE EYEBOLT
FROM TOP OF MOTOR AND SCREW
INTO END OF SHAFT.

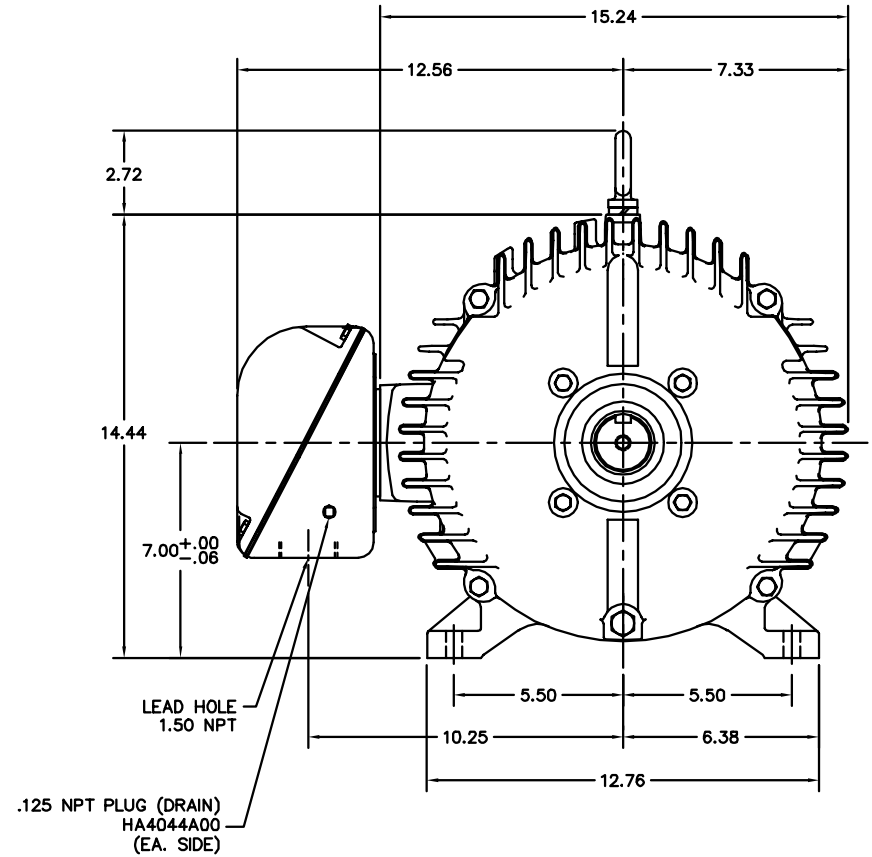

CUSTOMER IS RESPONSIBLE FOR DETERMINING THAT BALDOR'S PRODUCT WILL PERFORM SUITABLY IN THE INTENDED APPLICATION.

REV. DESC: UPDATE STACK RANGE TO 28 STACK		
REV. LTR: E	VERSION: 05	TDR: 000000539383
FILE: \AAA\00133\696	REVISED: 01:47:03 05/05/2010	BY: ENDANRO
MTL: -		

BALDOR

HORZ TEAO 284-6T CP, COOLING TOWER MTR, SLD BRGS, VERT LIFT

SH 1 of 1