

35LYVV807

510-520 = 11.12  
521-524 = 11.62  
525-528 = 12.13  
529-535 = 13.00  
536-546 = 14.38

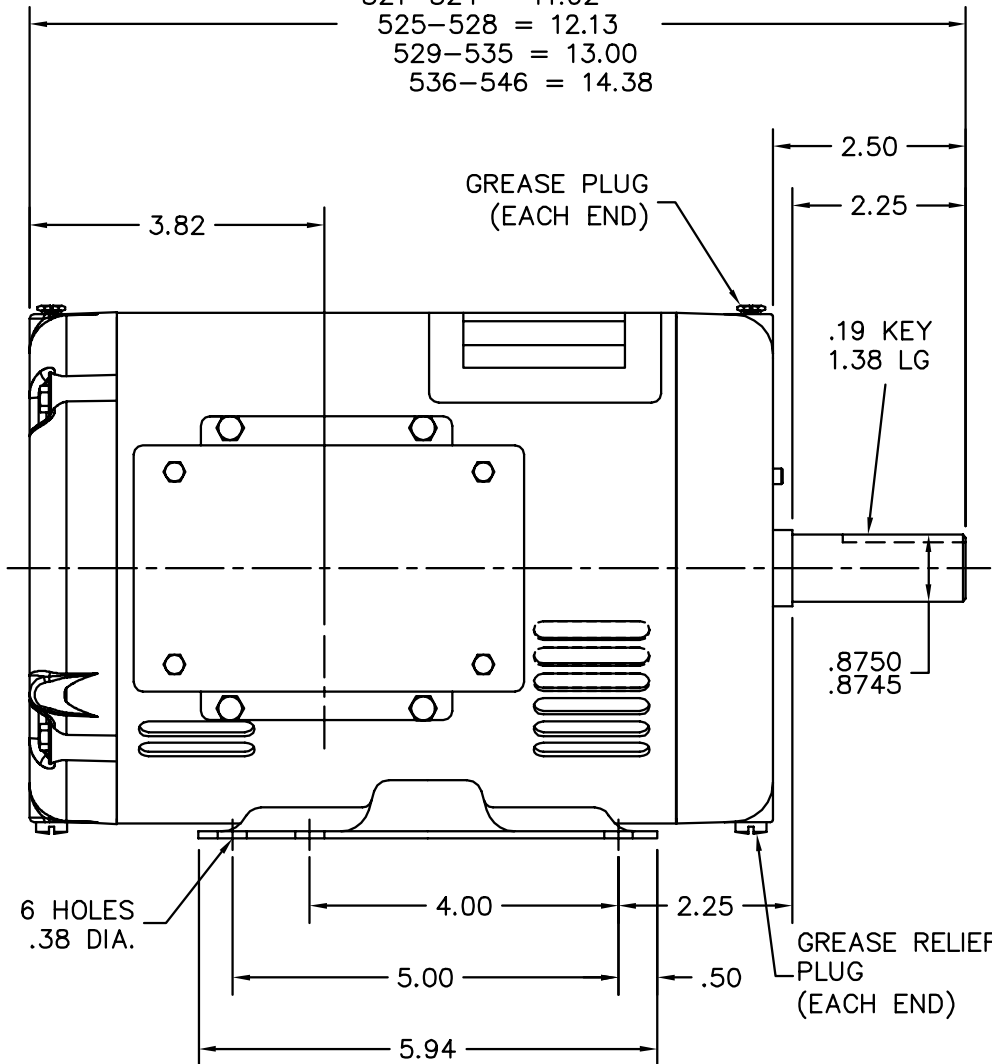

2 HOLES  
#5-40 TAP  
2.38 DIA. B.C.  
90° APART  
W/ SCREWS

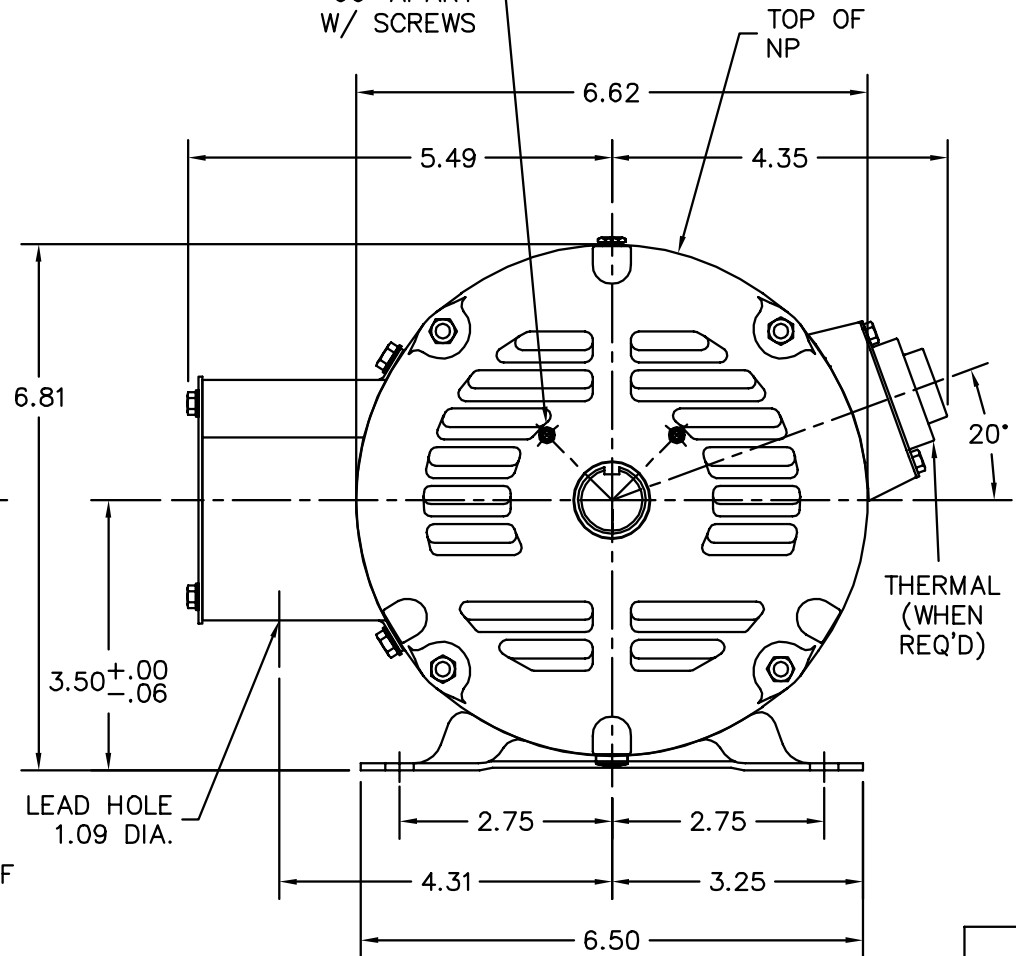

CUSTOMER IS RESPONSIBLE FOR DETERMINING THAT BALDOR'S PRODUCT WILL PERFORM SUITABLY IN THE INTENDED APPLICATION.

REV. DESC: ADDED AEGIS SPLIT RING MTG HOLES TO PULLEY EP

REV. LTR: A

VERSION: 01

TDR: 00000722739

FILE: \AAA\00177\280

REVISED: 11:28:27 11/29/2011

MTL: -

BY: ENBRAMO

**BALDOR**

HORZ 143-5T OPSB M (HVAC) W/GREASE PLUGS & 1.09 LH, AEGIS SR

SH 1 of 1

35LYVV807