

TOSHIBA/HOUSTON

DRIP-PROOF  
HORIZONTAL FOOT-MOUNTED

Fr. 505-509  
2 POLE  
DIRECT COUPLE

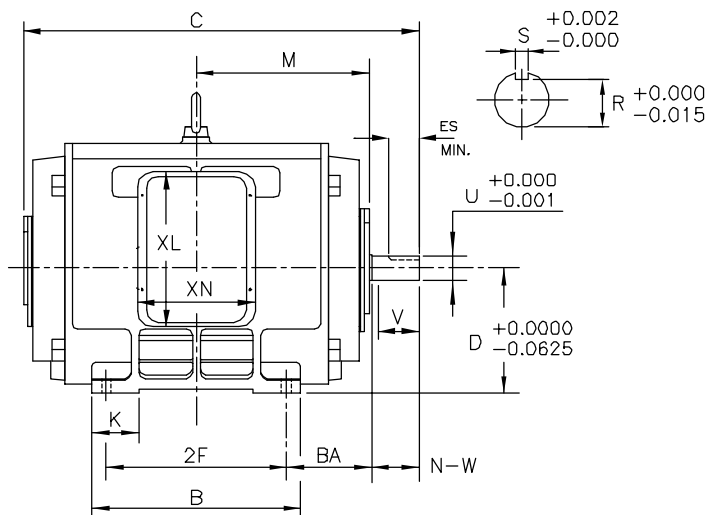
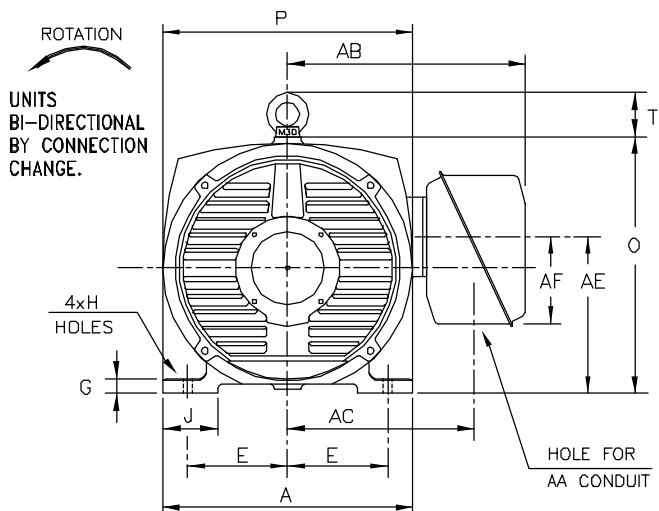

UNITS: INCHES

FRAME SIZE	MOUNTING				CONDUIT BOX						
	E	2F	H	BA	AA	AB	AC	AE	AF	XL	XN
505USS	10.00	18.00	0.94	8.50	4.00	23.8	18.6	15.6	8.7	15.5	11.7
507USS	10.00	22.00	0.94	8.50	4.00	23.8	18.6	15.6	8.7	15.5	11.7
509USS	10.00	28.00	0.94	8.50	4.00	22.8	17.7	15.6	8.7	15.5	11.7

FRAME SIZE	MOTOR DIMENSIONS										
	A	B	C	D	G	J	K	M	O	P	T
505USS	25.0	20.9	39.5	12.50	1.48	5.5	4.7	17.3	25.5	25.0	4.4
507USS	25.0	24.8	43.5	12.50	1.48	5.5	4.7	19.3	25.5	25.0	4.4
509USS	25.0	30.8	49.5	12.50	1.48	5.5	4.7	22.3	25.5	25.0	4.4

FRAME SIZE	SHAFT EXTENSION			KEYWAY			BEARINGS		MAXIMUM WEIGHT
	N-W	V	U	R	S	ES	LS	OS	
505USS	4.75	4.50	2.375	2.021	0.625	3.03	6313C3	6313C3	2100 lbs.
507USS	4.75	4.50	2.375	2.021	0.625	3.03	6313C3	6313C3	2500 lbs.
509USS	4.75	4.50	2.375	2.021	0.625	3.03	6313C3	6313C3	2800 lbs.

ALL DATA SUBJECT TO CHANGE WITHOUT NOTICE.  
FOR CONSTRUCTION USE ONLY CERTIFIED DATA.

NOTES:

1. DIMENSION V REPRESENTS LENGTH OF STRAIGHT PART OF SHAFT.
2. CONDUIT BOX MAY BE ROTATED IN 90° INCREMENTS AND MAY BE MOUNTED ON OPPOSITE SIDE ON SPECIAL ORDER.
3. KEY DIMENSIONS EQUAL S x S x 3.00 (MOTOR SUPPLIED WITH KEY)
4. MOTOR WEIGHT SHOWN IS MAXIMUM HORSEPOWER IN FRAME.

CERTIFIED DATA

CUSTOMER: \_\_\_\_\_ P.O. NO.: \_\_\_\_\_ TAG NO.: \_\_\_\_\_

MOTOR MODEL NO.: \_\_\_\_\_ TOSHIBA FILE NO.: \_\_\_\_\_

HP: \_\_\_\_\_ RPM (SYN.): \_\_\_\_\_ VOLTAGE: \_\_\_\_\_ Hz: \_\_\_\_\_

FRAME SIZE: \_\_\_\_\_ LOG NO.: \_\_\_\_\_ LOG REV. LEVEL: \_\_\_\_\_

REMARKS: \_\_\_\_\_

PER: \_\_\_\_\_ ISSUE DATE: \_\_\_\_\_ SUPERSEDES: \_\_\_\_\_

**TYPICAL MOTOR PERFORMANCE DATA**

Model: F3502VLG3JF

HP	kW	Pole	FL RPM	Frame	Voltage	Hz	Phase	FL Amps
350	261	2	3567	507USS	4000	60	3	46
Enclosure	IP	Ins. Class	S.F.	Duty	NEMA Nom. Eff.	NEMA Design	kVA Code	Ambient (°C)
ODP	12	F	1.15	CONT	93.7	B	F	40 C

Load	HP	kW	Amperes	Efficiency (%)	Power Factor (%)
Full Load	350	261.0	45.7	93.7	87.9
¾ Load	262.50	195.7	34.9	93.2	86.8
½ Load	175.00	130.5	24.8	91.6	82.8
¼ Load	87.50	65.2	16.0	86.3	67.9
No Load			9.4		9.2
Locked Rotor			273.20		26.1

Torque				Rotor wk <sup>2</sup>
Full Load (lb-ft)	Locked Rotor (% FLT)	Pull Up (% FLT)	Break Down (% FLT)	Inertia (lb-ft <sup>2</sup> )
515	130	105	185	68.27

Safe Stall Time(s)		Sound Pressure dB(A) @ 1M	Bearings*		Approx. Motor Weight (lbs)
Cold	Hot		DE	NDE	
12	2.7	-	6313C3	6313C3	

\*Bearings are the only recommended spare part(s).

**Motor Options:**  
Product Family:ODP & WP-I  
Mounting:Footed,Shaft:USS Shaft

Customer	
Customer PO	
Sales Order	
Project #	

Tag:

All characteristics are average expected values.

**TOSHIBA INTERNATIONAL CORPORATION · HOUSTON, TEXAS U.S.A.**

Engineering	bmmamen	Doc. Written By	D. Suarez	Doc.# / Rev	MPCF-1119 / 0
Engr. Date	7/24/2014	Doc. Approved By	M. Campbell	Doc. Issued	6/8/2011

**SPEED TORQUE/CURRENT CURVE**

Model: F3502VLG3JF

HP	kW	Pole	FL RPM	Frame	Voltage	Hz	Phase	FL Amps
350	261	2	3567	507USS	4000	60	3	46
Enclosure	IP	Ins. Class	S.F.	Duty	NEMA Nom. Eff.	NEMA Design	kVA Code	Ambient (°C)
ODP	12	F	1.15	CONT	93.7	B	F	40 C
Locked Rotor Amps	Rotor wk <sup>2</sup> Inertia (lb-ft <sup>2</sup> )	Torque						Break Down (%)
		Full Load (lb-ft)	Locked Rotor (%)	Pull Up (%)				
273.20	68.27	515	130	105			185	

**Design Values**

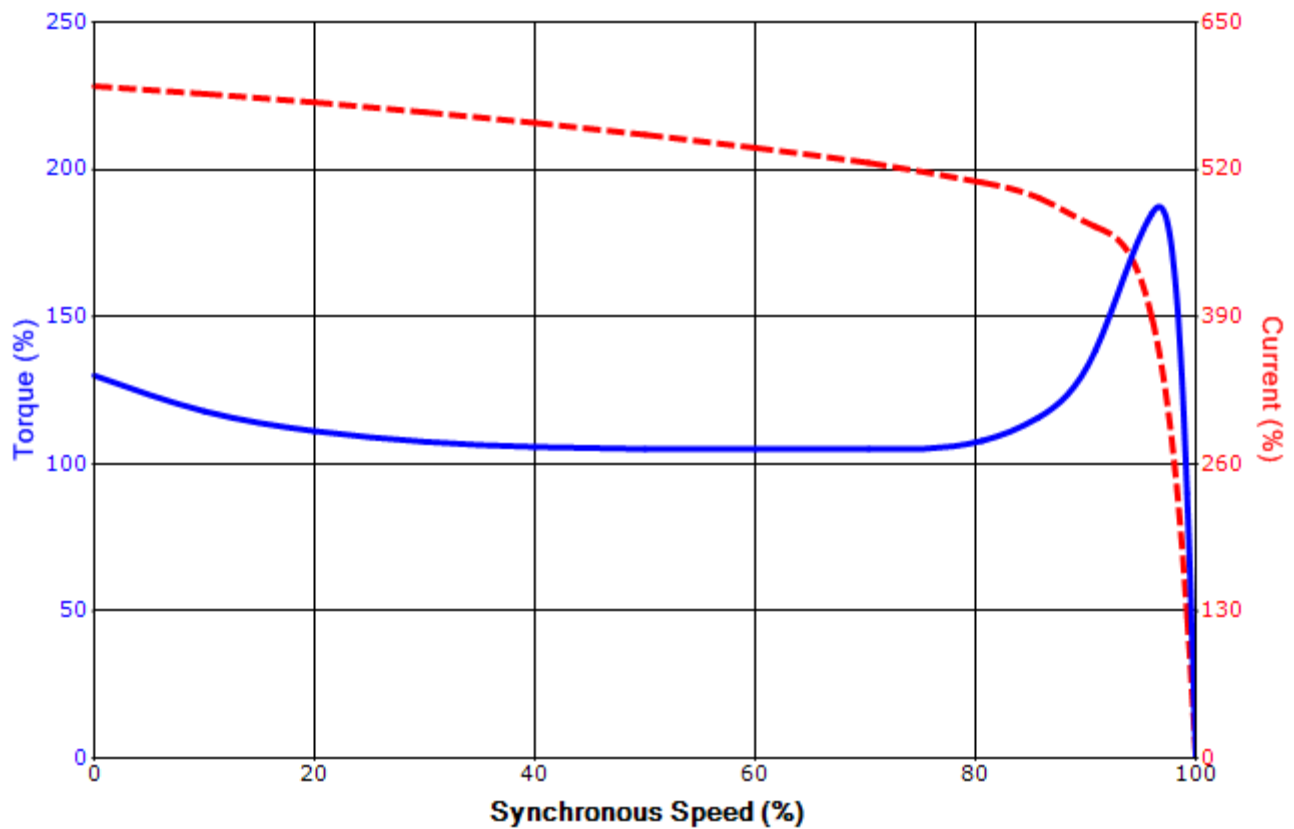

Customer		wk <sup>2</sup> Load Inertia (lb-ft <sup>2</sup> )	-
Customer PO		Load Type	-
Sales Order		Voltage (%)	100
Project #		Accel. Time	-

Tag:

All characteristics are average expected values.

**TOSHIBA INTERNATIONAL CORPORATION · HOUSTON, TEXAS U.S.A.**

Engineering	bmammen	Doc. Written By	D. Suarez	Doc.# / Rev	MPCF-1121 / 0
Engr. Date	7/24/2014	Doc. Approved By	M. Campbell	Doc. Issued	6/8/2011

**Motor Connection Diagrams**  
6 Leads

Across-the-Line Starting / Running Connections

Low Voltage – Delta



High Voltage – Wye

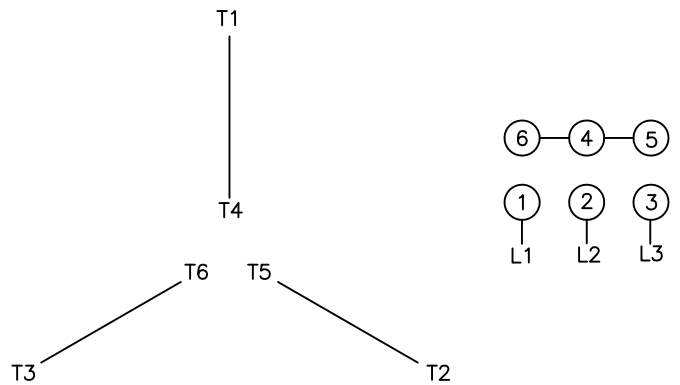

Switch L1 and L2 to reverse rotation