

INDEX	MDSL0081-06
REV. LEVEL	2
SHEET	1 OF 1

TOSHIBA/HOUSTON

**DRIP-PROOF
HORIZONTAL FOOT-MOUNTED
2300/4160V STOCK MOTORS**

**Fr. 505-509
4-8 POLE
DIRECT COUPLE**

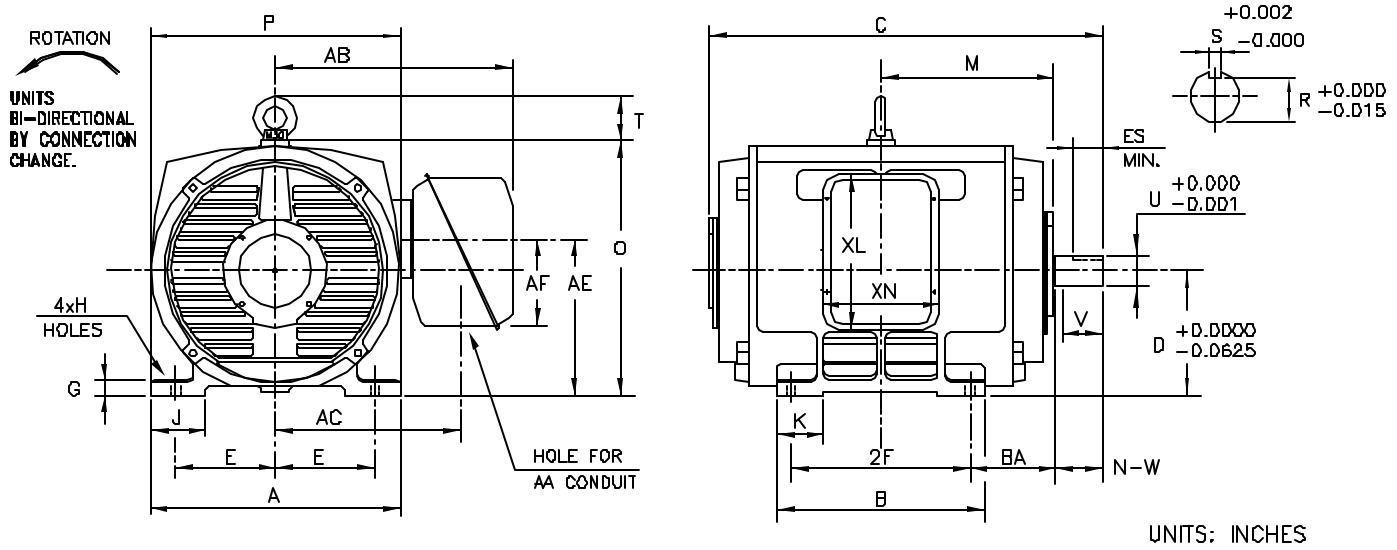

UNITS: INCHES

FRAME SIZE	MOUNTING				CONDUIT BOX						
	E	2F	H	BA	AA	AB	AC	AE	AF	XL	XN
505US	10.00	18.0	0.94	8.50	4.00	23.75	18.62	15.64	8.7	15.5	11.7
507US	10.00	22.0	0.94	8.50	4.00	23.75	18.62	15.64	8.7	15.5	11.7
509US	10.00	28.0	0.94	8.50	4.00	22.81	17.68	15.64	8.7	15.5	11.7

FRAME SIZE	MOTOR DIMENSIONS										
	A	B	C	D	G	J	K	M	O	P	T
505US	25.00	20.87	40.97	12.50	1.48	5.51	4.72	17.30	25.58	25.00	4.41
507US	25.00	24.80	44.97	12.50	1.48	5.51	4.72	19.30	25.58	25.00	4.41
509US	25.00	30.79	50.97	12.50	1.48	5.51	4.72	22.30	25.58	25.00	4.41

FRAME SIZE	SHAFT EXTENSION			KEY SEAT			BEARINGS		MAXIMUM WEIGHT
	N-W	V	U	S	R	ES	LS	OS	
505US	6.25	6.19	3.750	0.875	3.26	5.00	6320C3	6320C3	lbs.
507US	6.25	6.19	3.750	0.875	3.26	5.00	6320C3	6320C3	lbs.
509US	6.25	6.19	3.750	0.875	3.26	5.00	6320C3	6320C3	lbs.

ALL DATA SUBJECT TO CHANGE WITHOUT NOTICE.
FOR CONSTRUCTION USE ONLY CERTIFIED DATA.

CERTIFIED DATA

- NOTES:
1. DIMENSION V REPRESENTS LENGTH OF STRAIGHT PART OF SHAFT.
 2. CONDUIT BOX MAY BE ROTATED IN 90° INCREMENTS AND MAY BE MOUNTED ON OPPOSITE SIDE ON SPECIAL ORDER.
 3. KEY DIMENSIONS EQUAL 5 x 5 x 3.00 (MOTOR SUPPLIED WITH KEY)
 4. MOTOR WEIGHT SHOWN IS MAXIMUM HORSEPOWER IN FRAME.

CUSTOMER: _____ P.O. NO.: _____ TAG NO.: _____

MOTOR MODEL NO.: _____ TOSHIBA FILE NO.: _____

HP: _____ RPM (SYN.): _____ VOLTAGE: _____ Hz: _____

FRAME SIZE: _____ LOG NO.: _____ LOG REV. LEVEL: _____

REMARKS: _____

PER: _____ ISSUE DATE: _____ SUPERSEDES: _____

TYPICAL MOTOR PERFORMANCE DATA

Model: F4006VLF3JF

HP	kW	Pole	FL RPM	Frame	Voltage	Hz	Phase	FL Amps
400	298	6	1187	509US	4160	60	3	58
Enclosure	IP	Ins. Class	S.F.	Duty	NEMA Nom. Eff.	NEMA Design	kVA Code	Ambient (°C)
ODP	12	F	1.15	CONT	94.5	-	K	40 C

Load	HP	kW	Amperes	Efficiency (%)	Power Factor (%)
Full Load	400	298.3	58.0	95.2	74.5
¾ Load	300.00	223.7	51.6	94.6	67.5
½ Load	200.00	149.1	43.1	93.2	54.5
¼ Load	100.00	74.6	37.5	88.2	31.2
No Load			28.6		2.3
Locked Rotor			459.00		33.6

Torque				Rotor wk ²
Full Load (lb-ft)	Locked Rotor (% FLT)	Pull Up (% FLT)	Break Down (% FLT)	Inertia (lb-ft ²)
1770	255	235	330	176.81

Safe Stall Time(s)		Sound Pressure dB(A) @ 1M	Bearings*		Approx. Motor Weight (lbs)
Cold	Hot		DE	NDE	
8	2	-	6320C3	6320C3	

*Bearings are the only recommended spare part(s).

Motor Options:
Product Family:ODP & WP-I
Mounting:Footed,Shaft:US Shaft

Customer	
Customer PO	
Sales Order	
Project #	

Tag:

All characteristics are average expected values.

TOSHIBA INTERNATIONAL CORPORATION · HOUSTON, TEXAS U.S.A.

Engineering	gminetos	Doc. Written By	D. Suarez	Doc.# / Rev	MPCF-1119 / 0
Engr. Date	8/5/2013	Doc. Approved By	M. Campbell	Doc. Issued	6/8/2011

SPEED TORQUE/CURRENT CURVE

Model: F4006VLF3JF

HP	kW	Pole	FL RPM	Frame	Voltage	Hz	Phase	FL Amps
400	298	6	1187	509US	4160	60	3	58
Enclosure	IP	Ins. Class	S.F.	Duty	NEMA Nom. Eff.	NEMA Design	kVA Code	Ambient (°C)
ODP	12	F	1.15	CONT	94.5	-	K	40 C
Locked Rotor Amps	Rotor wk ² Inertia (lb-ft ²)	Torque						Break Down (%)
		Full Load (lb-ft)	Locked Rotor (%)	Pull Up (%)				
459.00	176.81	1770	255	235			330	

Design Values

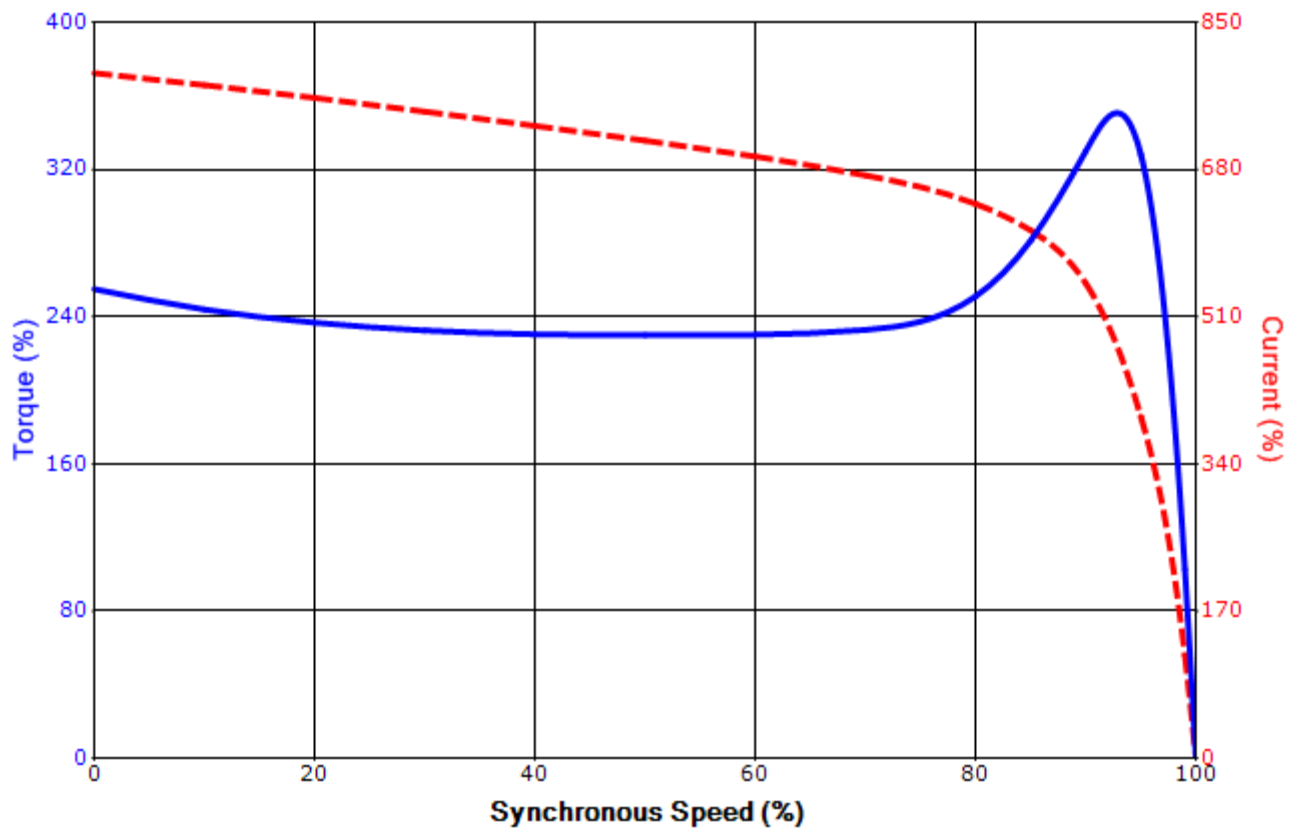

Customer		wk ² Load Inertia (lb-ft ²)	-
Customer PO		Load Type	-
Sales Order		Voltage (%)	100
Project #		Accel. Time	-

Tag:

All characteristics are average expected values.

TOSHIBA INTERNATIONAL CORPORATION · HOUSTON, TEXAS U.S.A.

Engineering	gminetos	Doc. Written By	D. Suarez	Doc.# / Rev	MPCF-1121 / 0
Engr. Date	8/5/2013	Doc. Approved By	M. Campbell	Doc. Issued	6/8/2011

Motor Connection Diagrams
6 Leads

Across-the-Line Starting / Running Connections

Low Voltage – Delta



High Voltage – Wye



Switch L1 and L2 to reverse rotation