

| | |
|------------|-------------|
| INDEX | MDSL0081-08 |
| REV. LEVEL | 1 |
| SHEET | 1 OF 1 |

TOSHIBA/HOUSTON

DRIP-PROOF
HORIZONTAL FOOT-MOUNTED
2300/4160V STOCK MOTORS

Fr. 587-5810
6-8 POLE
DIRECT COUPLE

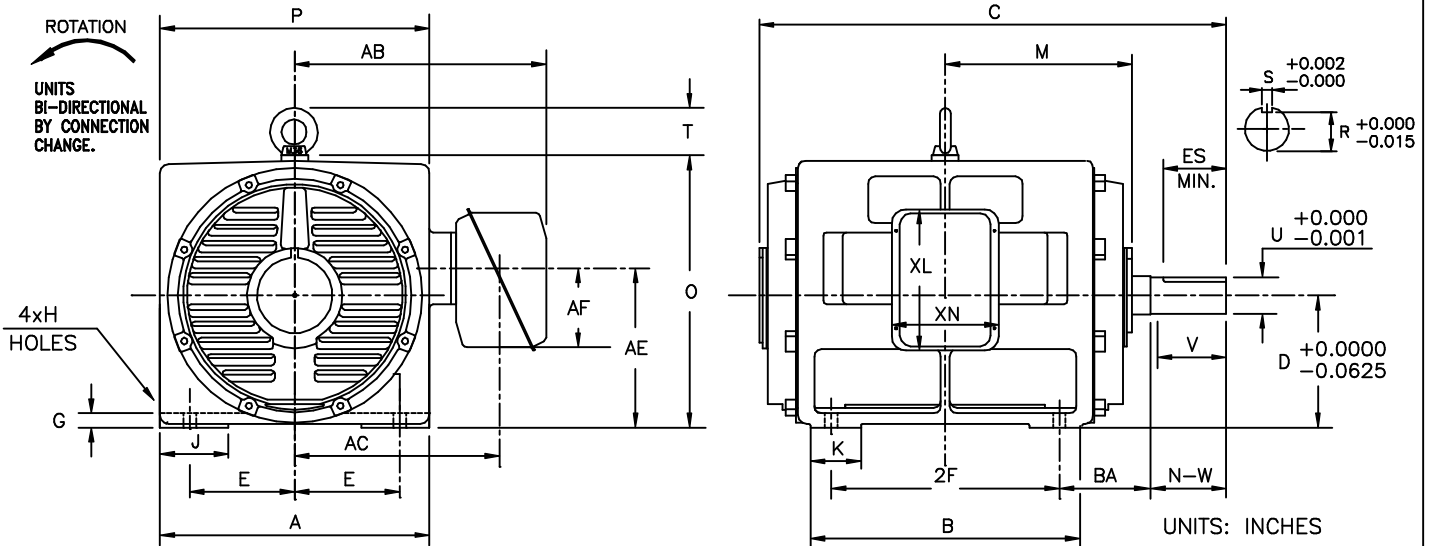

| FRAME SIZE | MOUNTING | | | | CONDUIT BOX | | | | | | |
|------------|----------|------|------|-------|-------------|-------|-------|------|-----|------|------|
| | E | 2F | H | BA | AA | AB | AC | AE | AF | XL | XN |
| 587US | 11.50 | 25.0 | 1.38 | 10.00 | 4.00 | 27.56 | 22.44 | 17.5 | 8.7 | 15.5 | 11.7 |
| 5810US | 11.50 | 36.0 | 1.38 | 10.00 | 4.00 | 27.56 | 22.44 | 17.5 | 8.7 | 15.5 | 11.7 |

| FRAME SIZE | MOTOR DIMENSIONS | | | | | | | | | | |
|------------|------------------|-------|-------|-------|------|------|------|-------|-------|-------|------|
| | A | B | C | D | G | J | K | M | O | P | T |
| 587US | 29.52 | 29.52 | 51.16 | 14.50 | 1.57 | 7.48 | 5.51 | 20.47 | 29.84 | 29.52 | 5.18 |
| 5810US | 29.52 | 40.55 | 61.98 | 14.50 | 1.57 | 7.48 | 9.84 | 25.79 | 29.84 | 29.52 | 5.18 |

| FRAME SIZE | SHAFT EXTENSION | | | KEY SEAT | | | BEARINGS | | MAXIMUM WEIGHT |
|------------|-----------------|------|-------|----------|-------|-------|----------|------|----------------|
| | N-W | V | U | R | S | ES | LS | OS | |
| 587US | 8.27 | 8.25 | 4.000 | 1.000 | 0.500 | 6.875 | 6322 | 6320 | lbs. |
| 5810US | 8.27 | 8.25 | 4.000 | 1.000 | 0.500 | 6.875 | 6322 | 6320 | lbs. |

ALL DATA SUBJECT TO CHANGE WITHOUT NOTICE.
FOR CONSTRUCTION USE ONLY CERTIFIED DATA.

FOR REFERENCE PRELIMINARY CERTIFIED

NOTES:

- DIMENSION V REPRESENTS LENGTH OF STRAIGHT PART OF SHAFT.
- CONDUIT BOX MAY BE ROTATED IN 90° INCREMENTS AND MAY BE MOUNTED ON OPPOSITE SIDE ON SPECIAL ORDER.
- KEY DIMENSIONS EQUAL S x S x 3.00 (MOTOR SUPPLIED WITH KEY)
- MOTOR WEIGHT SHOWN IS MAXIMUM HORSEPOWER IN FRAME.

CUSTOMER: _____ P.O. NO.: _____ TAG NO.: _____

MOTOR MODEL NO.: _____ TOSHIBA FILE NO.: _____

HP: _____ RPM (SYN.): _____ VOLTAGE: _____ Hz: _____

FRAME SIZE: _____ LOG NO.: _____ LOG REV. LEVEL: _____

REMARKS: _____

PER: _____ ISSUE DATE: _____ SUPERSEDES: _____

TYPICAL MOTOR PERFORMANCE DATA

Model: F7006VLF3JM

| HP | kW | Pole | FL RPM | Frame | Voltage | Hz | Phase | FL Amps |
|-----------|-----|------------|--------|--------|----------------|-------------|----------|--------------|
| 700 | 522 | 6 | 1189 | 5810US | 2402/4160 | 60 | 3 | 161/93 |
| Enclosure | IP | Ins. Class | S.F. | Duty | NEMA Nom. Eff. | NEMA Design | kVA Code | Ambient (°C) |
| ODP | 12 | F | 1.15 | CONT | 95.4 | - | E | 40 C |

| Load | HP | kW | Amperes | Efficiency (%) | Power Factor (%) |
|--------------|--------|-------|---------|----------------|------------------|
| Full Load | 700 | 522.0 | 92.1 | 96.1 | 85.0 |
| ¾ Load | 525.00 | 391.5 | 68.3 | 96.5 | 83.0 |
| ½ Load | 350.00 | 261.0 | 50.2 | 96.6 | 76.5 |
| ¼ Load | 175.00 | 130.5 | 35.8 | 92.5 | 54.6 |
| No Load | | | 26.7 | | 2.4 |
| Locked Rotor | | | 483.00 | | 21.4 |

| Torque | | | | Rotor wk ² Inertia (lb-ft ²) |
|----------------------|-------------------------|--------------------|-----------------------|---|
| Full Load (lb-ft) | Locked Rotor (% FLT) | Pull Up (% FLT) | Break Down (% FLT) | |
| 3092 | 95 | 100 | 215 | 297.07 |

| Safe Stall Time(s) | | Sound Pressure dB(A) @ 1M | Bearings* | | Approx. Motor Weight (lbs) |
|--------------------|-----|------------------------------|-----------|------------|-------------------------------|
| Cold | Hot | | DE | NDE | |
| 48 | 18 | - | 6322C3 | 6320C3 INS | |

*Bearings are the only recommended spare part(s).

Motor Options:
Product Family:ODP & WP-I
Mounting:Footed,Shaft:US Shaft

| | |
|-------------|--|
| Customer | |
| Customer PO | |
| Sales Order | |
| Project # | |

Tag:

All characteristics are average expected values.

TOSHIBA INTERNATIONAL CORPORATION · HOUSTON, TEXAS U.S.A.

| | | | | | |
|-------------|----------|------------------|-------------|-------------|---------------|
| Engineering | gminetos | Doc. Written By | D. Suarez | Doc.# / Rev | MPCF-1119 / 0 |
| Engr. Date | 8/7/2013 | Doc. Approved By | M. Campbell | Doc. Issued | 6/8/2011 |

SPEED TORQUE/CURRENT CURVE

Model: F7006VLF3JM

| | | | | | | | | |
|-------------------|---|-------------------|------------------|-------------|----------------|-------------|----------|----------------|
| HP | kW | Pole | FL RPM | Frame | Voltage | Hz | Phase | FL Amps |
| 700 | 522 | 6 | 1189 | 5810US | 2402/4160 | 60 | 3 | 161/93 |
| Enclosure | IP | Ins. Class | S.F. | Duty | NEMA Nom. Eff. | NEMA Design | kVA Code | Ambient (°C) |
| ODP | 12 | F | 1.15 | CONT | 95.4 | - | E | 40 C |
| Locked Rotor Amps | Rotor wk ² Inertia (lb-ft ²) | Torque | | | | | | Break Down (%) |
| | | Full Load (lb-ft) | Locked Rotor (%) | Pull Up (%) | | | | |
| 483.00 | 297.07 | 3092 | 95 | 100 | | | 215 | |

Design Values

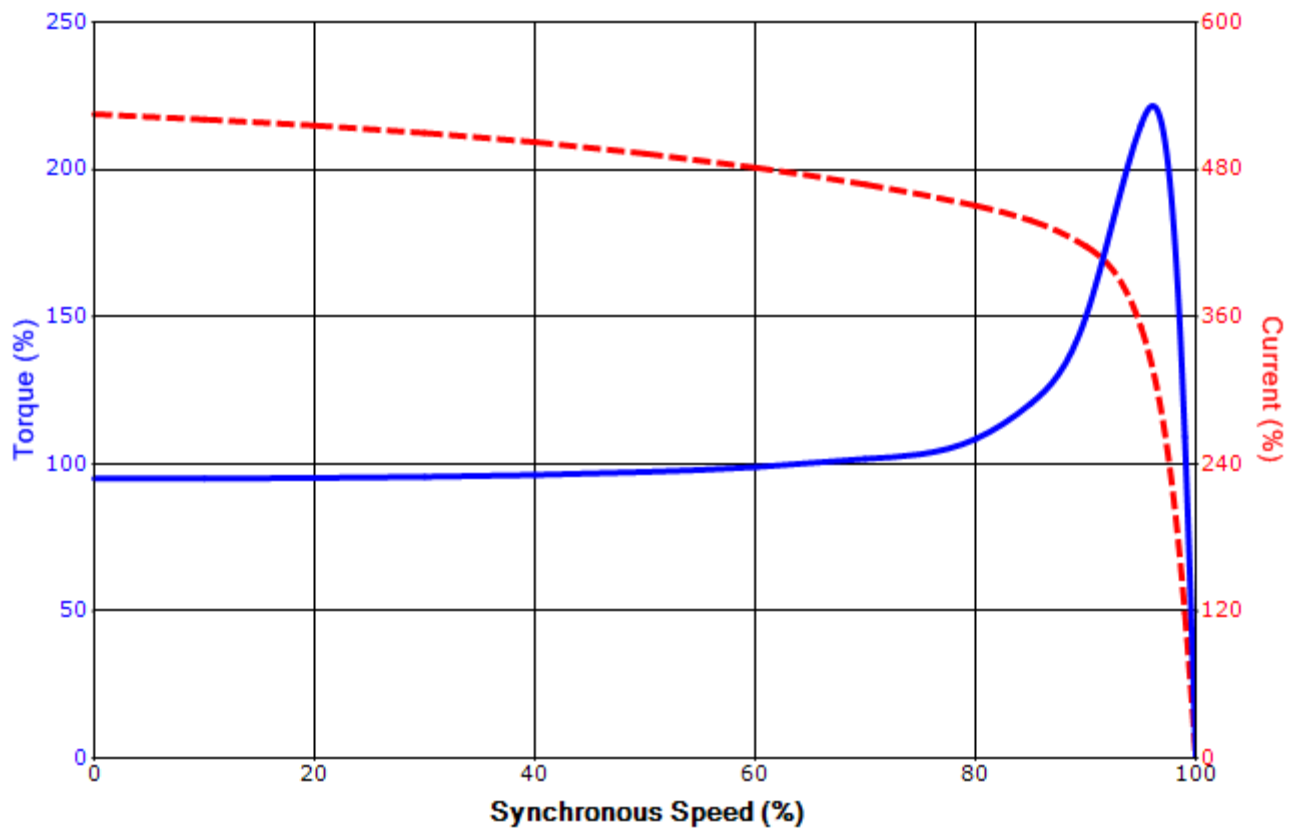

| | | | |
|-------------|--|--|-----|
| Customer | | wk ² Load Inertia (lb-ft ²) | - |
| Customer PO | | Load Type | - |
| Sales Order | | Voltage (%) | 100 |
| Project # | | Accel. Time | - |

Tag:

All characteristics are average expected values.

TOSHIBA INTERNATIONAL CORPORATION · HOUSTON, TEXAS U.S.A.

| | | | | | |
|-------------|----------|------------------|-------------|-------------|---------------|
| Engineering | gminetos | Doc. Written By | D. Suarez | Doc.# / Rev | MPCF-1121 / 0 |
| Engr. Date | 8/7/2013 | Doc. Approved By | M. Campbell | Doc. Issued | 6/8/2011 |

Motor Connection Diagrams
6 Leads

Across-the-Line Starting / Running Connections

Low Voltage – Delta



High Voltage – Wye



Switch L1 and L2 to reverse rotation