

36.00 MIN. OUT OF YOKE
SJTOW 16/3
WHITE, BLACK & GREEN
.50/.25 LEAD STRIP
1.00 JACKET STRIP

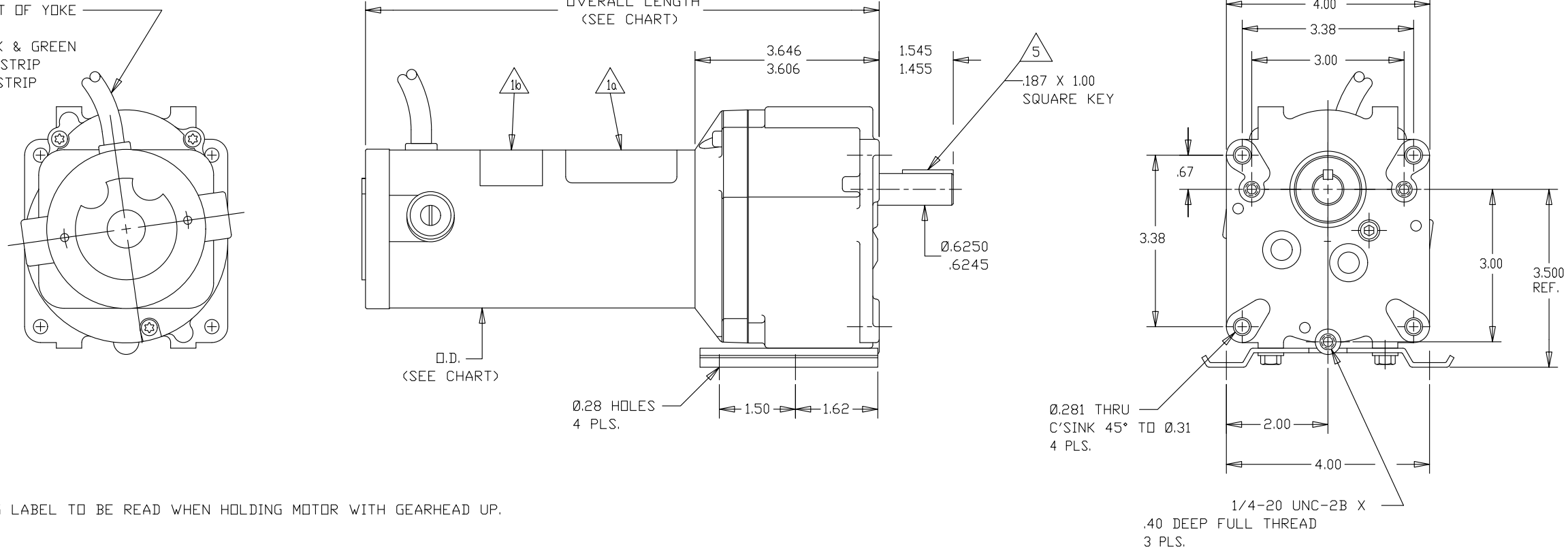

NOTES:

- 1. NAMEPLATE AND WARNING LABEL TO BE READ WHEN HOLDING MOTOR WITH GEARHEAD UP.
 - a. NAMEPLATE
 - b. WARNING LABEL
- 2. GEARMOTOR ROTATION: C.W.D.E & C.C.W.D.E.
- 3. PAINT SPECIFICATION: BLACK
- 4. WAVE SPING WASHER AND BEARING COVER PLATE TO BE APPLIED TO THE BRUSH END BELL SIDE OF THE MOTOR.
- 5. KEY (14653195) TO BE TAPED TO THE OUTPUT SHAFT.

WEG CAT. NO.	SIZE	O.D.	OVERALL LENGTH	H.P.	TORQUE	SPEED	VOLTS	F.F.	AMPS	RATIO
GH2020	M6030	3.27	10.081/10.006	0.25	35 IN-LBS	358 R.P.M.	90 D.C.	1.0	2.29	5:1
GH2019		3.27	10.081/10.006	0.25	280 IN-LBS	42 R.P.M.	90 D.C.	1.25	2.45	57.7:1
GH2018		3.27	10.081/10.006	0.25	235 IN-LBS	62 R.P.M.	90 D.C.	1.4	2.83	57.7:1
GH2017		3.27	10.081/10.006	0.25	160 IN-LBS	83 R.P.M.	90 D.C.	1.2	2.53	30:1
GH2016		3.27	10.081/10.006	0.25	90 IN-LBS	165 R.P.M.	90 D.C.	1.4	2.93	20:1
GH2015		3.27	10.081/10.006	0.25	40 IN-LBS	350 R.P.M.	90 D.C.	1.4	2.7	11:1
GH2014	M4100	3.13	8.081/8.006	0.05	82 IN-LBS	34 R.P.M.	90 D.C.	1.4	0.94	57.7:1
GH2013		3.13	8.081/8.006	0.05	55 IN-LBS	51 R.P.M.	90 D.C.	1.4	0.94	34:1
GH2012		3.13	8.081/8.006	0.05	28 IN-LBS	111 R.P.M.	90 D.C.	1.4	0.97	17.5:1
GH2003		3.13	8.081/8.006	0.13	150 IN-LBS	18 R.P.M.	90 D.C.	1.1	0.82	103:1
GH2002		3.13	8.081/8.006	0.05	268 IN-LBS	9 R.P.M.	90 D.C.	1.1	0.75	202:1
GH2001		3.13	8.081/8.006	0.05	290 IN-LBS	6 R.P.M.	90 D.C.	1.4	0.62	343:1
GH2011	M4300	3.13	10.081/10.006	0.13	21 IN-LBS	362 R.P.M.	90 D.C.	1.0	1.62	5:1
GH2010		3.13	10.081/10.006	0.13	47 IN-LBS	165 R.P.M.	90 D.C.	1.0	1.57	11:1
GH2009		3.13	10.081/10.006	0.13	86 IN-LBS	91 R.P.M.	90 D.C.	1.0	1.58	20:1
GH2008		3.13	10.081/10.006	0.13	113 IN-LBS	61 R.P.M.	90 D.C.	1.0	1.42	30:1
GH2007		3.13	10.081/10.006	0.13	138 IN-LBS	54 R.P.M.	90 D.C.	1.0	1.51	34:1
GH2006		3.13	10.081/10.006	0.13	220 IN-LBS	32 R.P.M.	90 D.C.	1.0	1.5	58:1
GH2005		3.13	10.081/10.006	0.13	280 IN-LBS	26 R.P.M.	90 D.C.	1.0	1.58	69:1
GH2004		3.13	10.081/10.006	0.13	280 IN-LBS	21 R.P.M.	90 D.C.	1.0	1.3	88:1

UNLESS OTHERWISE SPECIFIED: TOLERANCE - DECIMAL		PESO BRUTO / GROSS WEIGHT		PESO NETO / NET WEIGHT		ESC / SCALE		1:1			
.XX	±015	EJEC. / EXECUTED	COGINSKI	500002832554	07	REVISED SHAFT-BASE PLATE DIM	COGINSKI	JCOLLINS	JCOLLINS	31.01.2025	07
.XXX	±005	VERIF. / CHECKED	RAFAELAMS	500002679067	06	REVISED NOTE #1 & LEADERS-FLIPPED LABELS	COGINSKI	RAFAELAMS	RAFAELAMS	10.07.2024	06
.XXXX	±002	LIBER. / RELEASED	RAFAELAMS	No MODIFICACION ECM	LOC LOC	RESUMEN DE MODIFICACIONES SUMMARY OF MODIFICATIONS	EJECUTADO EXECUTED	VERIFICADO CHECKED	LIBERADO RELEASED	FECHA DATE	VER VER
ANGLE	±1/2°	FECHA LBREL DT	12.09.2023	WBL	McHENRY	ENGINEERING	HOJA/SHEET	/			

10011421794
000 | 07

