

PULLEY END DETAIL

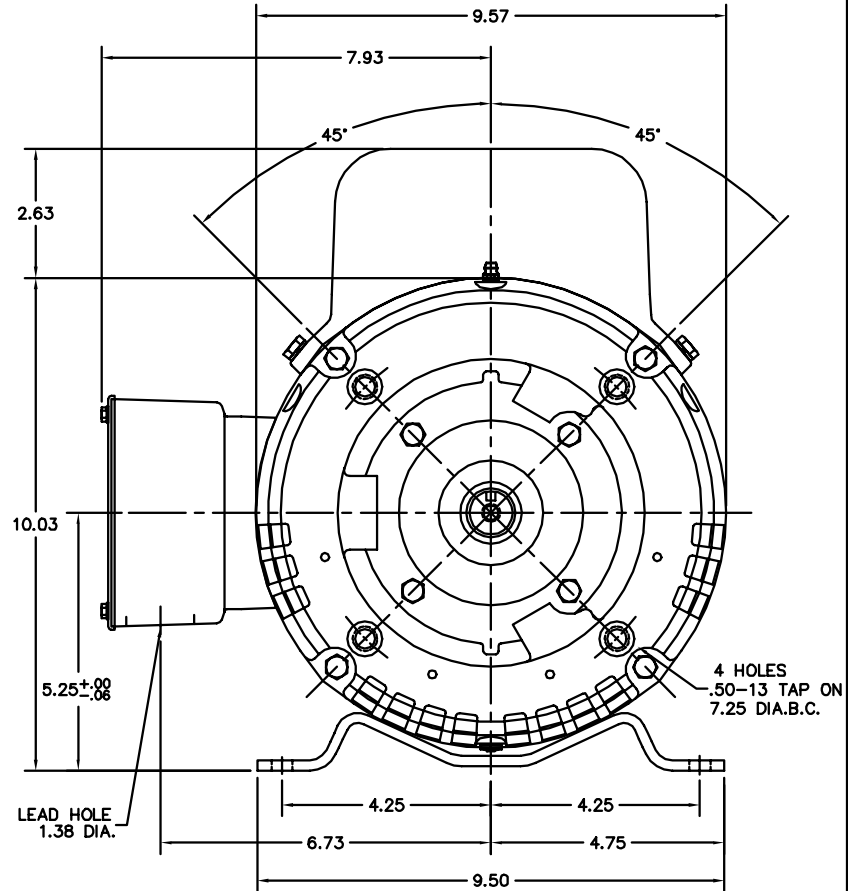

CUSTOMER IS RESPONSIBLE FOR DETERMINING THAT BALDOR'S PRODUCT WILL PERFORM SUITABLY IN THE INTENDED APPLICATION.

REV. DESC:	REVISE DESCRIPTION	
REV. LTR:	N	VERSION: 02
FILE:	AAA\00016\829	REVISED: 11:08:35 06/03/2008
MTL:	-	BY: ENBRAMO
		TDR: 000000466511

BALDOR • DODGE • RELIANCE

STD 213-5JM OPEN HORZ 37L/LC

SH 1 of 1