

SECTION A-A  
LABEL UNDER C'BOX LID

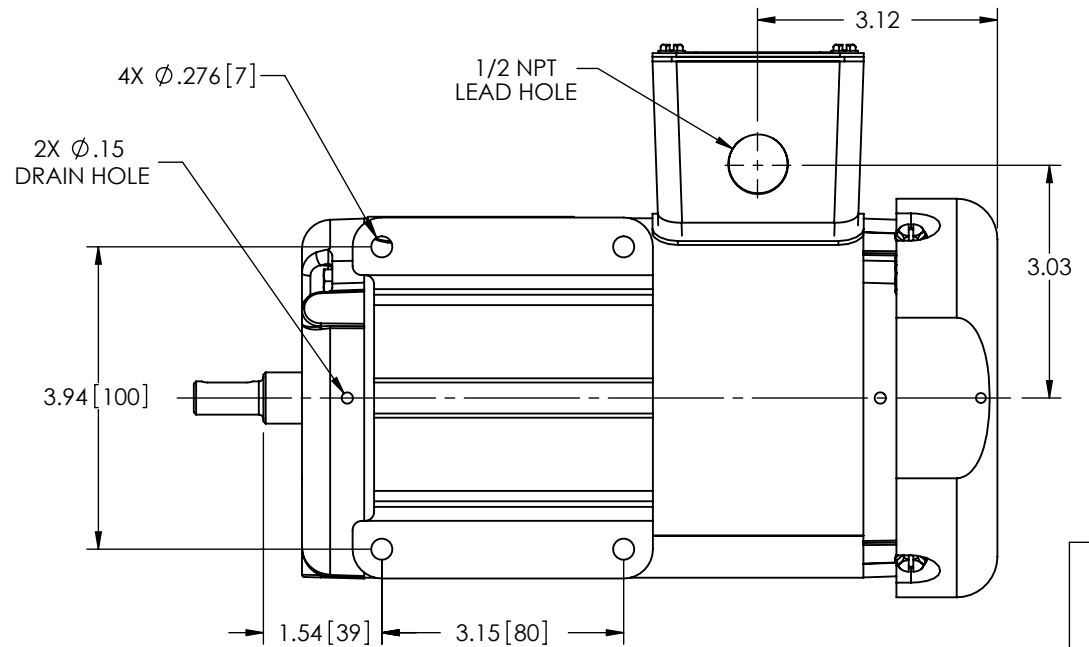
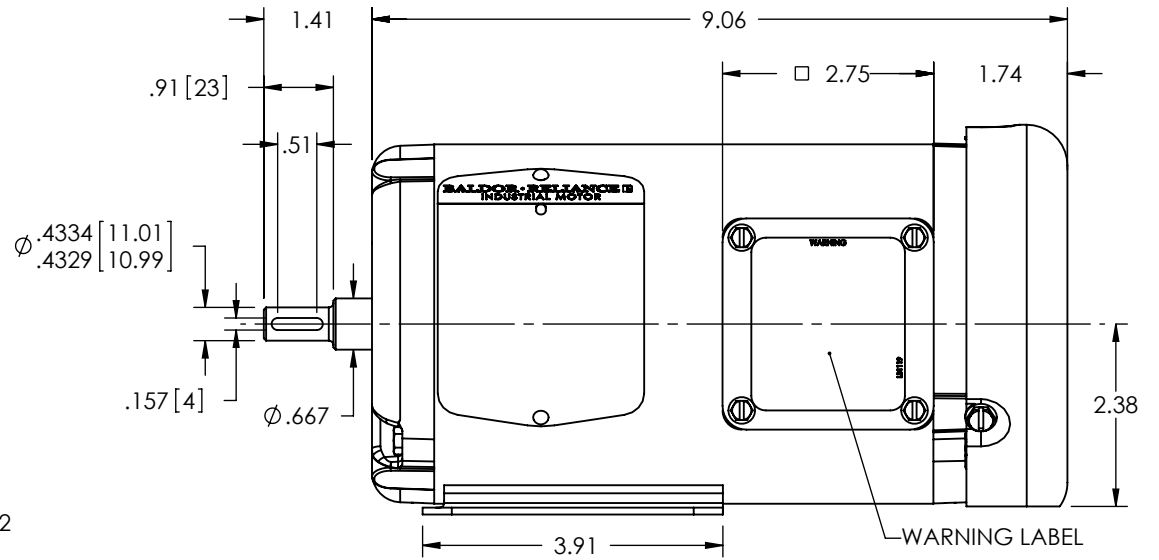

REV. DESC: NEW

REV: -    VERSION: 00    REVISED: 10:28:04 07/23/2008    TDR: 000000467504

33-1792-422G1

MODEL NO. 33-1792

BY: CKPHIW0

REF:

**BALDOR ELECTRIC Co.**

LY,33AC MTR RSB TEFC GP W/BASE 11M X 35MM EXT

33-1792-422G1

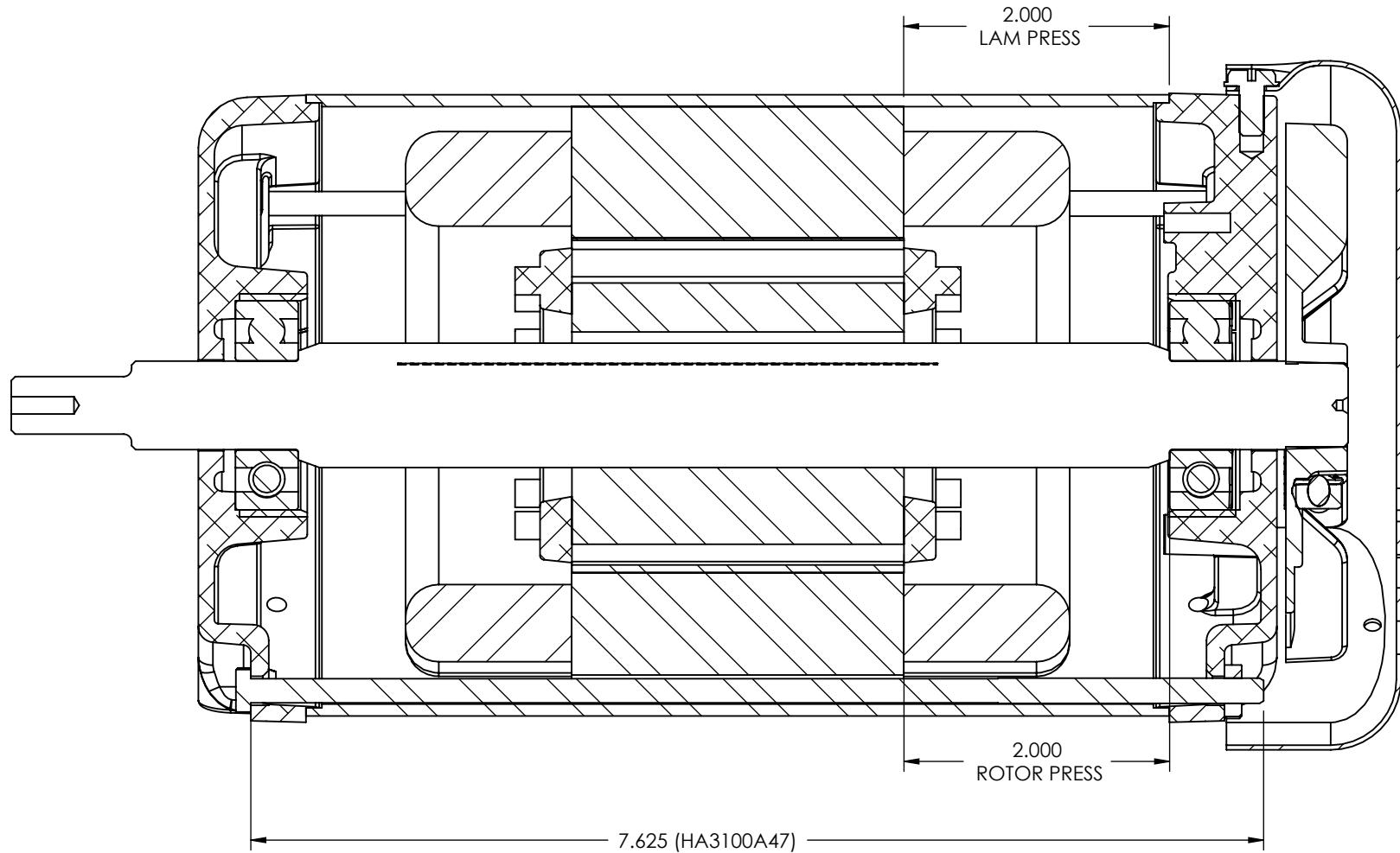
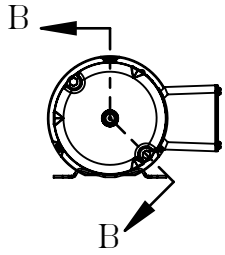

SECTION B-B

REV. DESC: NEW

REV: -    VERSION: 00

REVISED: 10:28:04 07/23/2008

TDR: 000000467504

**BALDOR • DODGE • RELIANCE**

33-1792-422G1

MODEL NO. 33-1792

REF:

BY: CKPHIWO

LY,33AC MTR RSB TEFC GP W/BASE 11M X 35MM EXT

33-1792-422G1

33-1792-422G1

ITEM NO.	PART NUMBER	33-1792-422G1/QTY.
1	33EP3100A02	1
2	33EP3100A01	1
3	SKF - 6203 - 10,DE,NC,10_68	2
4	33sb0185b00	1
5	33RC4120-03	1
6	34GS1029	1
7	51XB1016A07	2
8	11XW1032G06	1
9	34GS1031A01	1
10	34CB4517	1
11	51XW0832A07	4
12	HA5100A03	1
13	33FN3000	1
14	12XN0832A16	1
15	HW1003A08	1
16	XY0832A02	1
17	XY1032A02	2
18	11XT1032A06	3
19	HA3100A47	2
20	NP1896	1
21	BMH4109	2
22	LC0005	1
23	34CB3002A16	1
24	33SH1045B02	1
25	LB1119	1
26	33FH4001A01	1

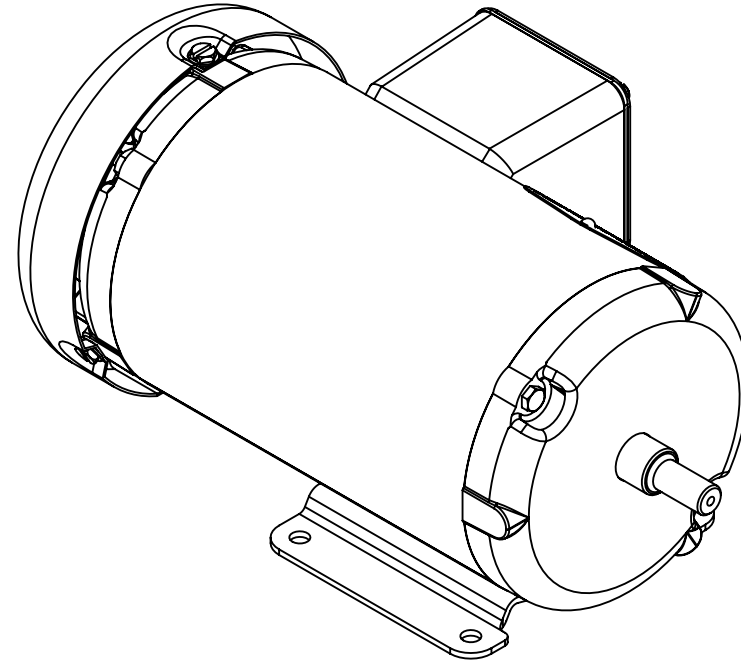

REV. DESC: NEW

REV: - VERSION: 00

REVISED: 10:28:04 07/23/2008

TDR: 000000467504

**BALDOR • DODGE • RELIANCE**

33-1792-422G1

MODEL NO. 33-1792

REF:

BY: CKPHIW0

LY,33AC MTR RSB TEFC GP W/BASE 11M X 35MM EXT

33-1792-422G1