

DESCRIPTION:
GEARMOTOR 22B2BEBL-Z4

SHEET: 1/1
SCALE: 1:1
C

UNLESS OTHERWISE SPECIFIED:
UNITS ARE IN INCHES [mm]
TOLERANCES: .XX:±.01 .XXX:±.005
ANGLES: X°:±3° X.X°:±0.5°

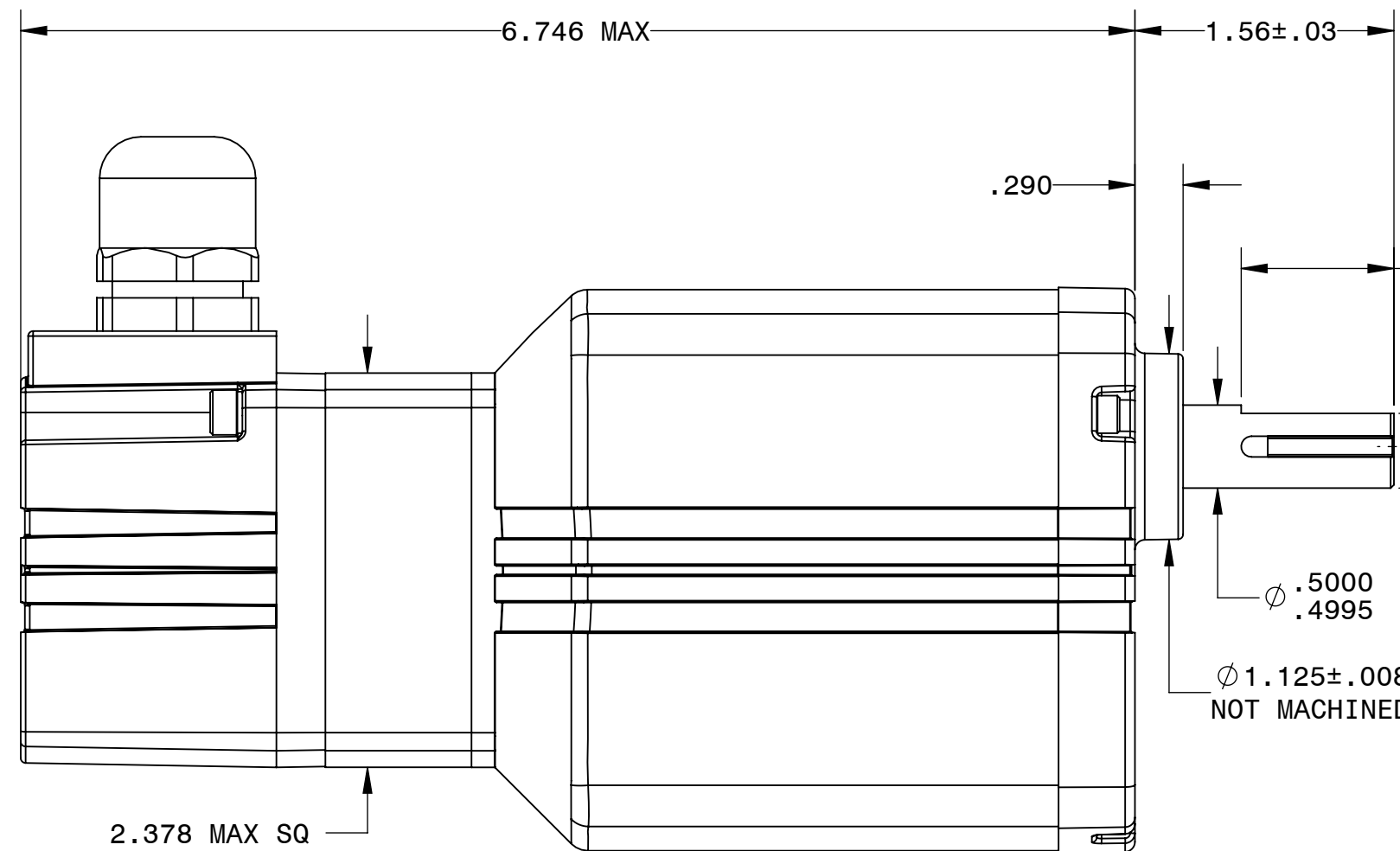
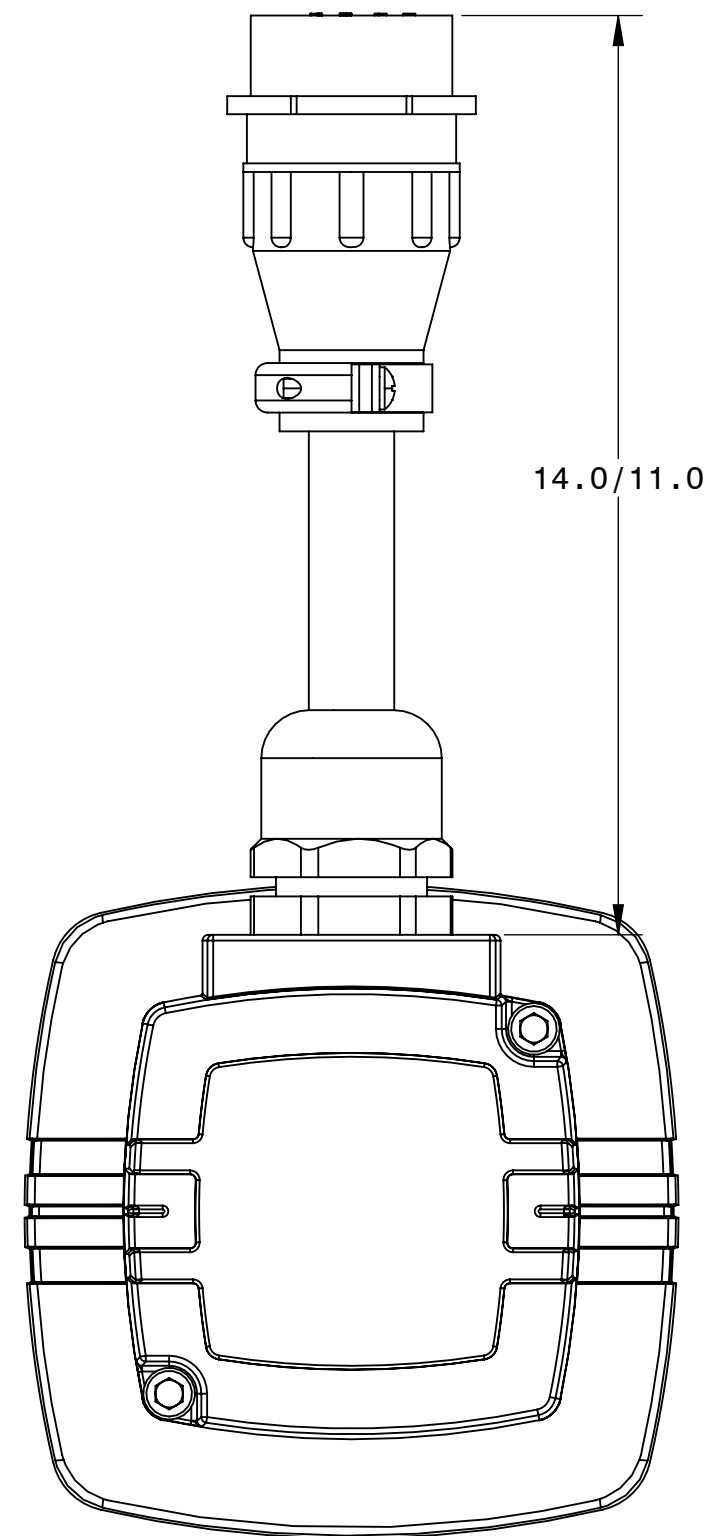

.124±.001 SQ
X .75 LONG KEY

.92±.02
FLAT
.450

∅ .5000
.4995

∅ 1.125±.008
NOT MACHINED

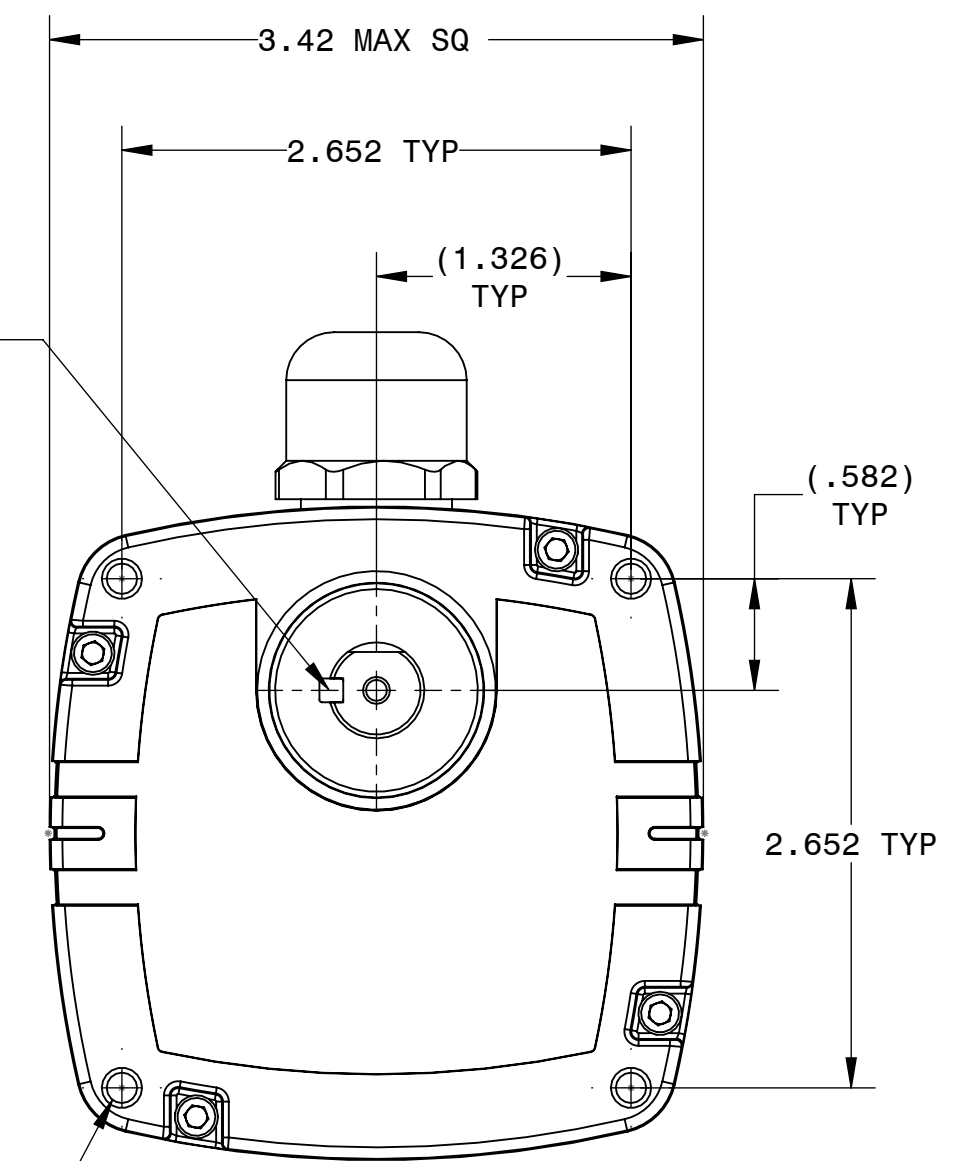

[4] #10-32 UNF-2B
.455 MIN

REPRESENTATIVE OF MODEL NUMBER(S):
3364

