

# BODINE ELECTRIC COMPANY

PART NO./REV: INFM0278 B	
DESCRIPTION: GEARMOTOR 34B4BEBL-E/F	
SHEET: 1/1	UNLESS OTHERWISE SPECIFIED:
SCALE: 1:2	UNITS ARE IN INCHES [mm]
<b>B</b>	TOLERANCES: .XX:±.01 .XXX:±.005
	ANGLES: X°:±3° X.X°:±0.5°

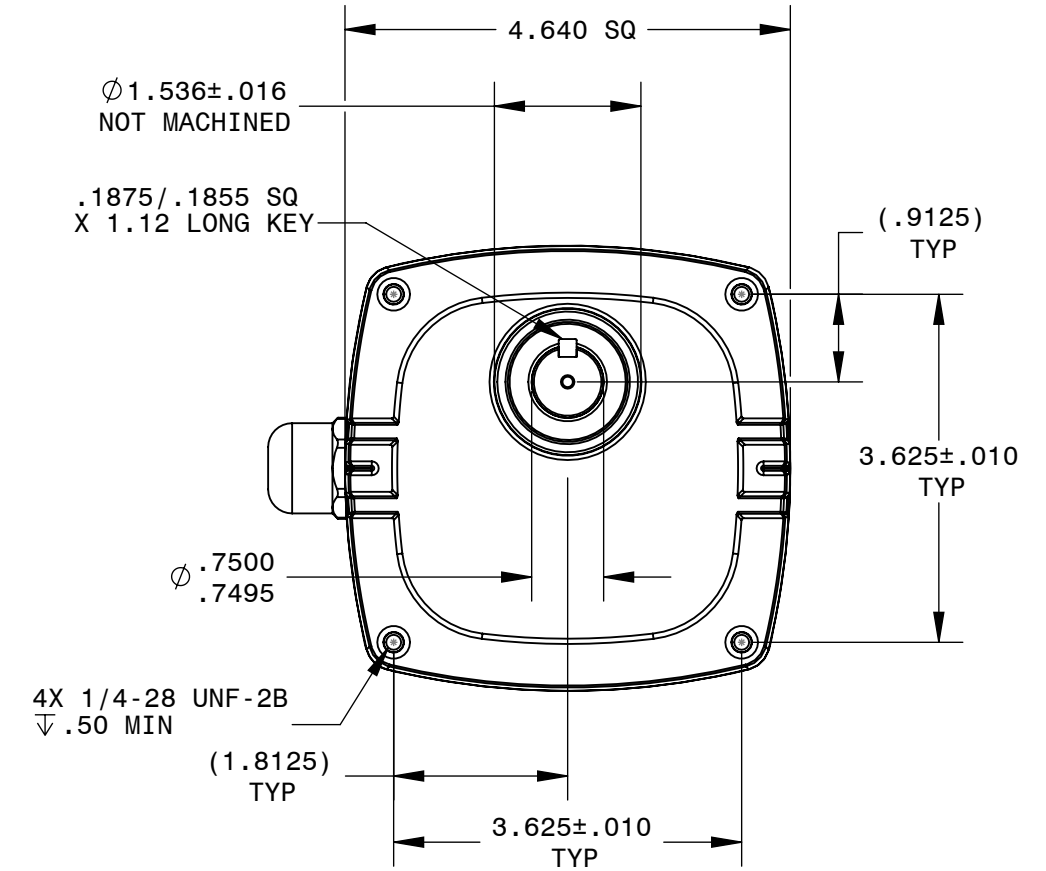

REPRESENTATIVE OF MODEL NUMBER(S):  
3583 3584 3585 3582 3580 3579

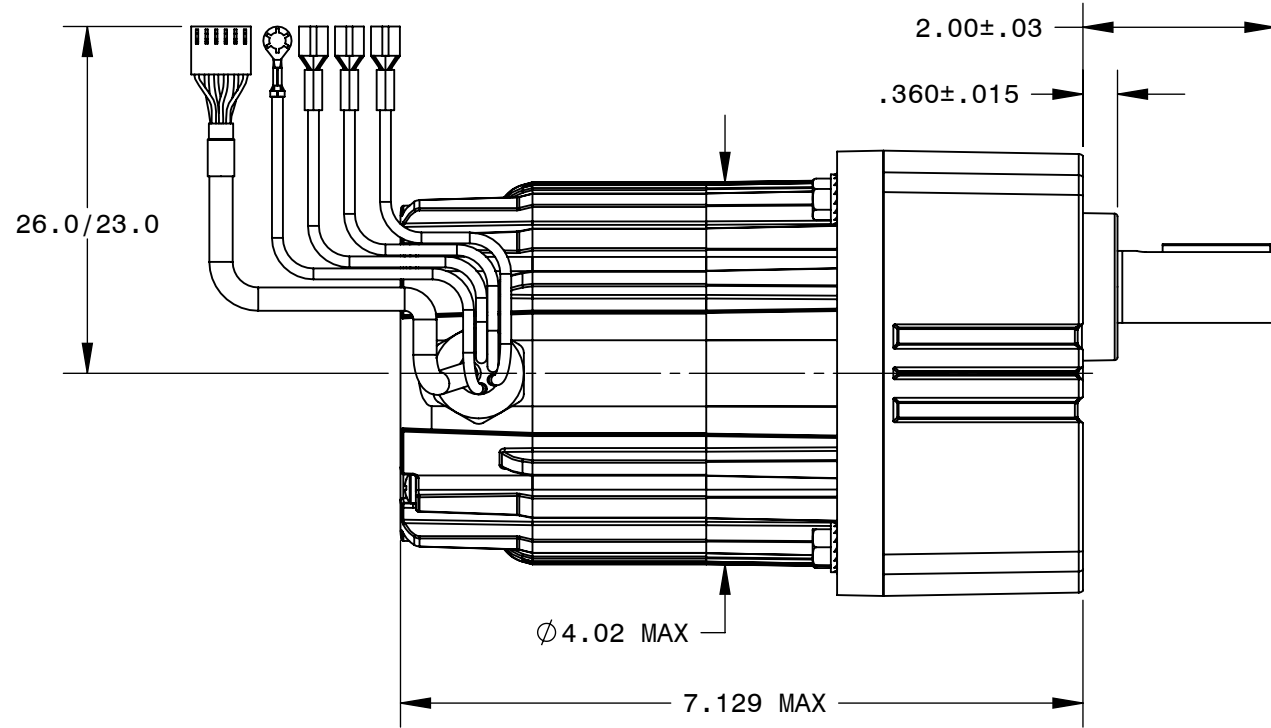
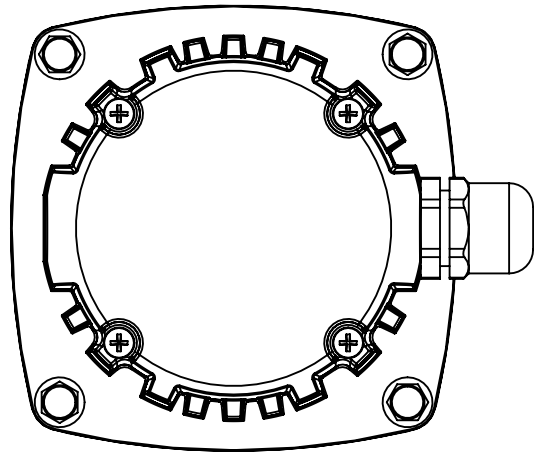
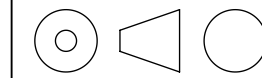