

DCN300-6

1Q PWM Microprocessor-based
Adjustable Speed Drive
for Low Voltage PMDC Brushed Motors

Specifications

Model	Source Voltage (VDC)	Armature Voltage Range (VDC)	Peak Armature Current (Amps)	Motor Horsepower Range
DCN300-6	12	Up to 95%	6*	1/100 - 1/30
	24	of Source Voltage**		1/50 - 1/15

* Peak current rating for 1 minute. Continuous current rating is 3 amps.

** Output voltage is 1 VDC less than the input voltage. The 1 VDC drop is a result of a reverse polarity protection diode. This diode can be removed for OEM's who do not need reverse polarity protection.

Source Voltage.....	10 - 32 VDC
Form Factor.....	1.01 at base speed
Acceleration Time Range.....	0.25 seconds
Deceleration Time Range.....	0.25 seconds
Analog Input Voltage Range.....	0 - 5 VDC
Input Impedance (S1 to S2).....	>100K ohms
Load Regulation.....	1% base speed
Speed Range.....	80:1
Vibration (0 - 50 Hz).....	0.5G maximum
(>50 Hz).....	0.1G maximum
Ambient Temperature Range.....	0°C - 40°C
Weight.....	0.04 lbs

Safety Warnings

READ ALL SAFETY WARNINGS BEFORE INSTALLING THIS EQUIPMENT

- **DO NOT INSTALL, REMOVE, OR REWIRE THIS EQUIPMENT WITH POWER APPLIED.** Have a qualified electrical technician install, adjust and service this equipment. Follow the National Electrical Code and all other applicable electrical and safety codes, including the provisions of the Occupational Safety and Health Act (OSHA), when installing equipment.
- Avoid direct contact with the printed circuit board or with circuit elements to prevent the risk of serious injury or fatality. Use a non-metallic screwdriver for adjusting the calibration trim pots. Use approved personal protection equipment and insulated tools if working on this drive with power applied.
- Reduce the chance of an electrical fire, shock, or explosion by using proper grounding techniques, over-current protection, thermal protection, and enclosure. Follow sound maintenance procedures.
- **Removing DC power is the only acceptable method for emergency stopping.** Do not use decelerating to minimum speed or coasting to a stop for emergency stopping. They may not stop a drive that is malfunctioning. Removing DC power is the only acceptable method for emergency stopping.
- Applying and removing DC source voltage is recommended for infrequent starting and stopping of a drive only. Regenerative braking, decelerating to minimum speed, or coasting to a stop is recommended for frequent starts and stops. Frequent starting and stopping can produce high torque. This may cause damage to motors.
- **Do not disconnect any of the motor leads from the drive** unless power is removed or the drive is disabled. Opening any one lead while the drive is running may destroy the drive.
- Under no circumstances should power and logic level wires be bundled together.
- Be sure potentiometer tabs do no make contact with the potentiometer's body. Grounding the input may cause damage to the drive.

Dimensions

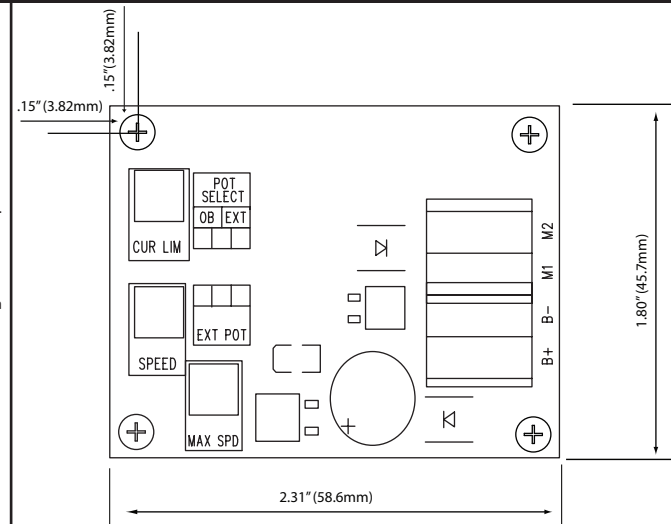

Height: 1.0 [25]

ALL DIMENSIONS IN INCHES [MILLIMETERS]

Installation

Mounting

- Drive components are sensitive to electrostatic discharge. Avoid direct contact with the circuit components.
- Protect the drive from dirt, moisture, and accidental contact.
- Provide sufficient room for access to the terminal blocks and calibration trim pot.
- Mount the drive away from heat sources. Operate the drive within the specified ambient operating temperature range.
- Prevent loose connections by avoiding excessive vibration of the drive.
- Mount the drive with its board in either a horizontal or vertical plane. Four 0.15" (4 mm) wide holes in the board accept #6 pan head screws.

Wiring

Use 18 - 24 AWG wire for logic wiring.
Use 16 - 20 AWG wire for DC source (B+, B-) and motor (A1, A2) wiring.

Shielding Guidelines

As a general rule, ACE recommends shielding of all conductors. If it is not practical to shield power conductors, ACE recommends shielding all logic-level leads. If shielding of logic-level leads is not practical, the user should twist all logic leads with themselves to minimize induced noise. It may be necessary to earth ground the shielded cable. If noise is produced by devices other than the drive, ground the shield at the drive end. If noise is generated by the drive, ground the shield at the end away from the drive. Do not ground both ends of the shield.

Fusing

ACE drives require an external line fuse for protection. Use fast acting fuses rated for at least 150% of the maximum armature voltage and current. Fuse the positive terminal.

Connections

Input Power

Connect the DC input power leads to terminals B+ (positive) and B- (negative).

Motor

Connect the DC armature leads to terminals A1 and A2. If the motor does not spin in the desired direction, power down the drive and reverse these connections.

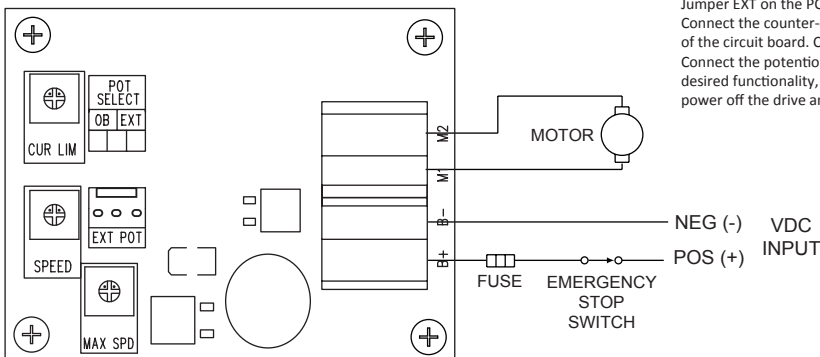

On-board Trim Pot

If no remote speed control is desired, jumper OB on the POT SELECT jumper. Use the SPEED trim pot to set the motor speed.



Speed Potentiometer

Jumper EXT on the POT SELECT jumper to use a 10K ohm, 1/4 W potentiometer for speed control. Connect the counter-clockwise end of the potentiometer to the EXT POT terminal closest to the outside of the circuit board. Connect the potentiometer wiper to the middle terminal of the EXT POT header. Connect the potentiometer supply to the inside terminal. If the potentiometer works inversely of desired functionality, (i.e. to increase motor speed, you must turn the potentiometer counterclockwise), power off the drive and swap the outer connections.

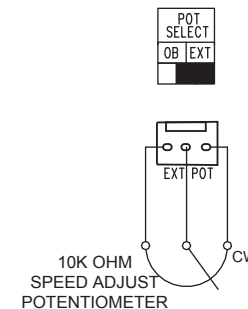

Startup

STARTUP

- Verify that no foreign conductive material is present on the printed circuit board.

1. Turn the speed adjust potentiometer full counterclockwise (CCW).
2. Apply DC source voltage.
3. Slowly advance the speed adjust potentiometer clockwise (CW). The motor slowly accelerates as the potentiometer is turned CW. Continue until the desired speed is reached.
4. Remove DC source voltage from the drive to coast the motor to a stop.

Operation

DECELERATING & STOPPING

Decelerate to Zero Speed (Coast)

The switch shown below may be used to decelerate a motor to a zero speed. Opening the switch decelerates the motor from set speed to zero speed. By closing the switch, the motor accelerates to set speed.

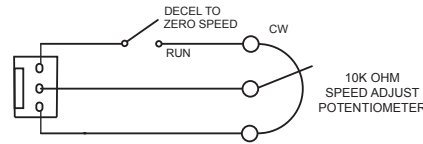

Decelerate to Zero Speed (Dynamic Brake)

Dynamic braking may be used to rapidly stop a motor. For the RUN/BRAKE switch, use a two pole, two position switch rated for at least the armature voltage rating and 150% of the armature current rating. For the dynamic brake resistor, use a high power, wirewound resistor. Sizing the dynamic brake resistor depends on load inertia, motor voltage, and braking time. Use a lower-value, higher-wattage dynamic brake resistor to stop a motor more rapidly.

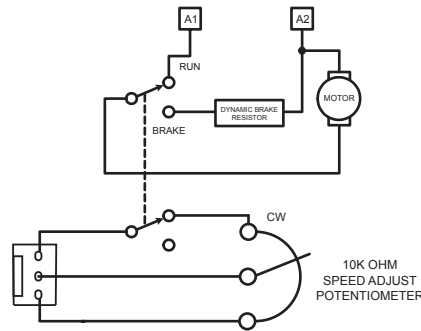

REVERSING

Reversing with a Dynamic Brake

A dynamic brake may be used when reversing the motor direction. Use a three pole, three position switch rated for at least the armature voltage rating and 150% of the armature current rating. For the dynamic brake resistor, use a high power, wirewound resistor. Sizing the dynamic brake resistor depends on load inertia, motor voltage, and braking time. Use a lower-value, higher-wattage dynamic brake resistor to stop a motor more rapidly.

The motor must come to a complete stop before changing directions.

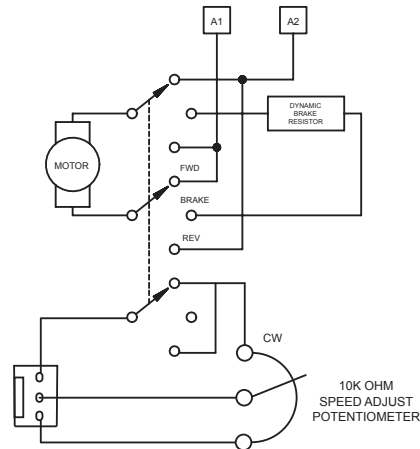

Calibration

Maximum Speed (MAX SPD): The MAX SPD setting determines the maximum motor speed when the speed adjust potentiometer or on-board SPEED trim pot are set for maximum speed. To calibrate the MAX SPD:

1. Set the MAX SPD trim pot full CCW.
2. Set the speed adjust potentiometer or SPEED trim pot for maximum speed.
3. Adjust the MAX SPD trim pot until the desired maximum speed is reached.

Torque (CUR LIM): The CUR LIM setting determines the maximum torque for accelerating and driving the motor. To calibrate the CUR LIM:

1. With the power disconnected from the drive, connect a DC ammeter in series with the armature.
2. Set the CUR LIM trim pot to minimum (full CCW).
3. Set the speed adjust potentiometer to maximum forward speed (full CW).
4. Carefully lock the motor armature. Be sure that the motor is firmly mounted.
5. Apply power source. The motor should be stopped.
6. Slowly adjust the CUR LIM trim pot CW until the armature current is 150% of motor rated armature current.
7. Turn the speed adjust potentiometer to minimum speed (full CCW).
8. Remove power source.
9. Remove the stall from the motor.
10. Remove the ammeter in series with the motor armature if it is no longer needed.



0.1 Amps



3 Amps



6 Amps



1 Amp



4 Amps



2 Amps



5 Amps