

1 X  $\phi$ .88 KNOCKOUT (PU. END)  
 2 X  $\phi$ .88 KNOCKOUTS (FR. END)

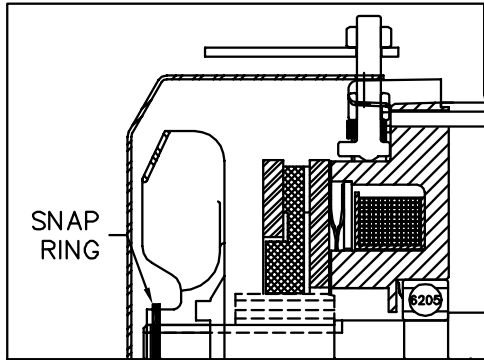
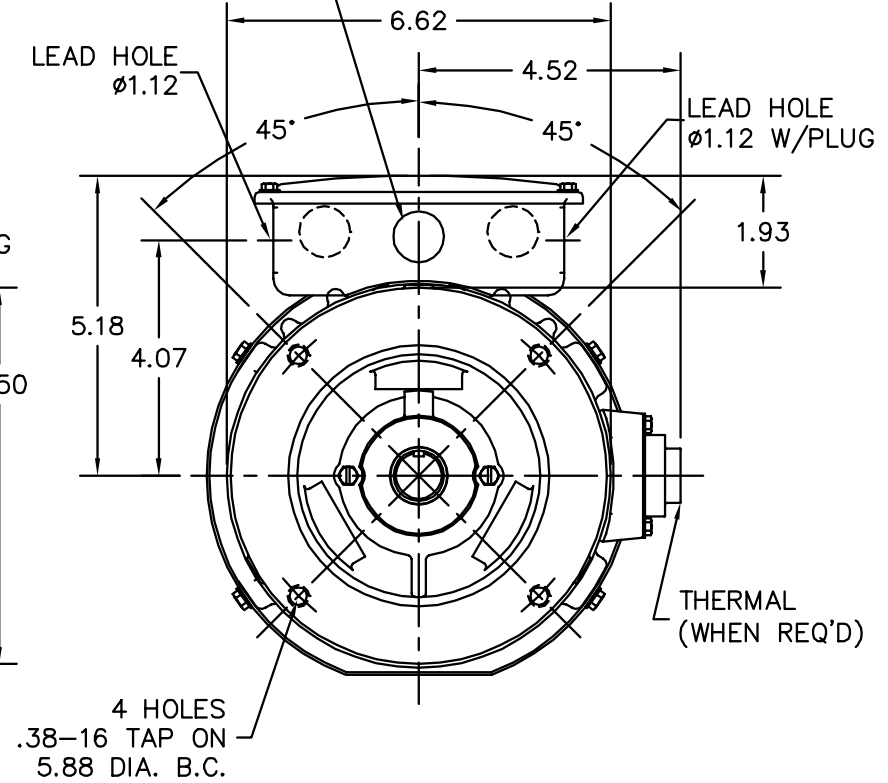
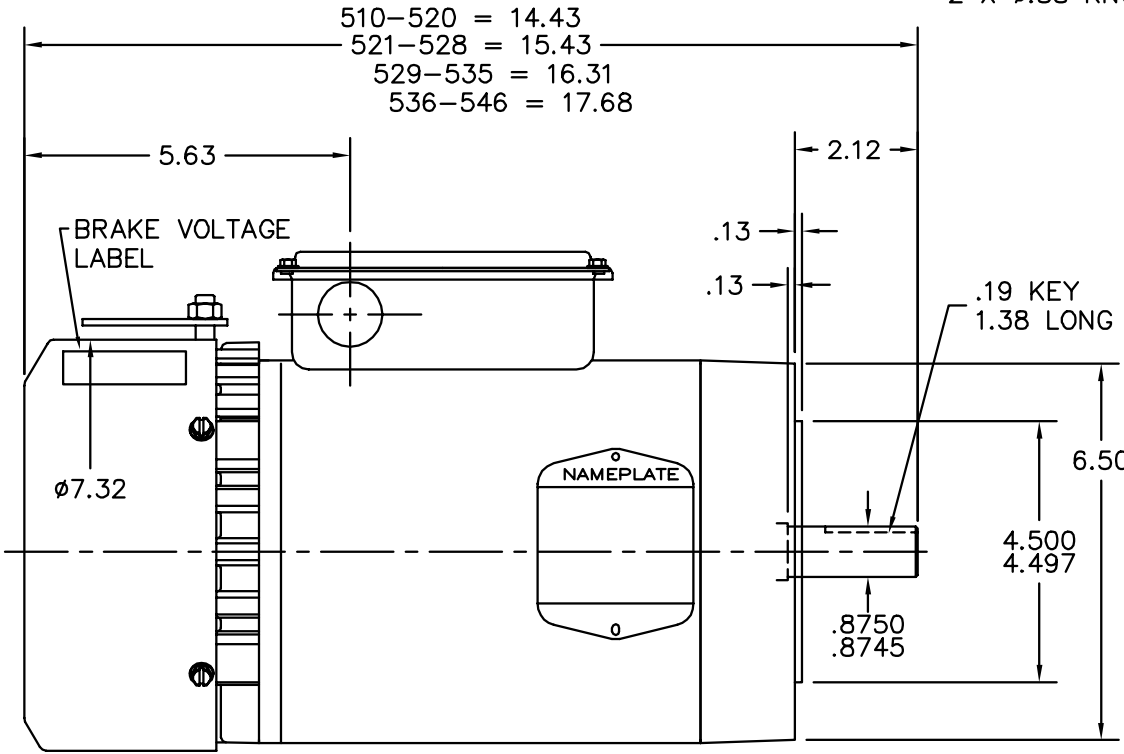

FRONT DETAIL VIEW

CUSTOMER IS RESPONSIBLE FOR DETERMINING THAT MOTOR PERFORMANCE IS SUITABLE IN THE APPLICATION.

REV. DESC: NEW		
REV. LTR: -	VERSION: 00	TDR: 000000448556
$\angle$ 90X179C	FILE: \AAA\00152\808	REVISED: 08: 45: 07 12/06/2007
	MTL: -	BY: ENALEMO

**BALDOR • DODGE • RELIANCE**

VER 143-5TC TEFC 35M F3 W/DODGE SSB BRAKE & 35CB4007