

FRONT END DETAIL

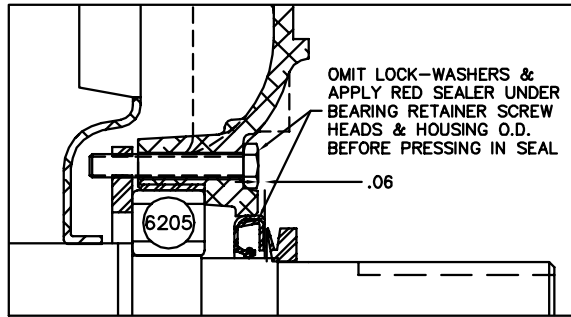

PULLEY END DETAIL

CUSTOMER IS RESPONSIBLE FOR DETERMINING THAT BALDOR'S PRODUCT WILL PERFORM SUITABLY IN THE INTENDED APPLICATION.

REV. DESC: REPLACE HA1005A05 WITH HW4600B39	VERSION: 02	TDR: 00000798580
REV. LTR: B	REvised: 08:43:46 05/08/2013	BY: ENADAFO
FILE: \AAA\00177\243	MTL: -	

**BALDOR**

VERT 143-5TC TEFC 35M WD (S/P 9) W/.75 NPT LEAD HOLE

SH 1 of 1