

1 X ϕ .88 KNOCKOUT (PU. END)
 2 X ϕ .88 KNOCKOUTS (FR. END)

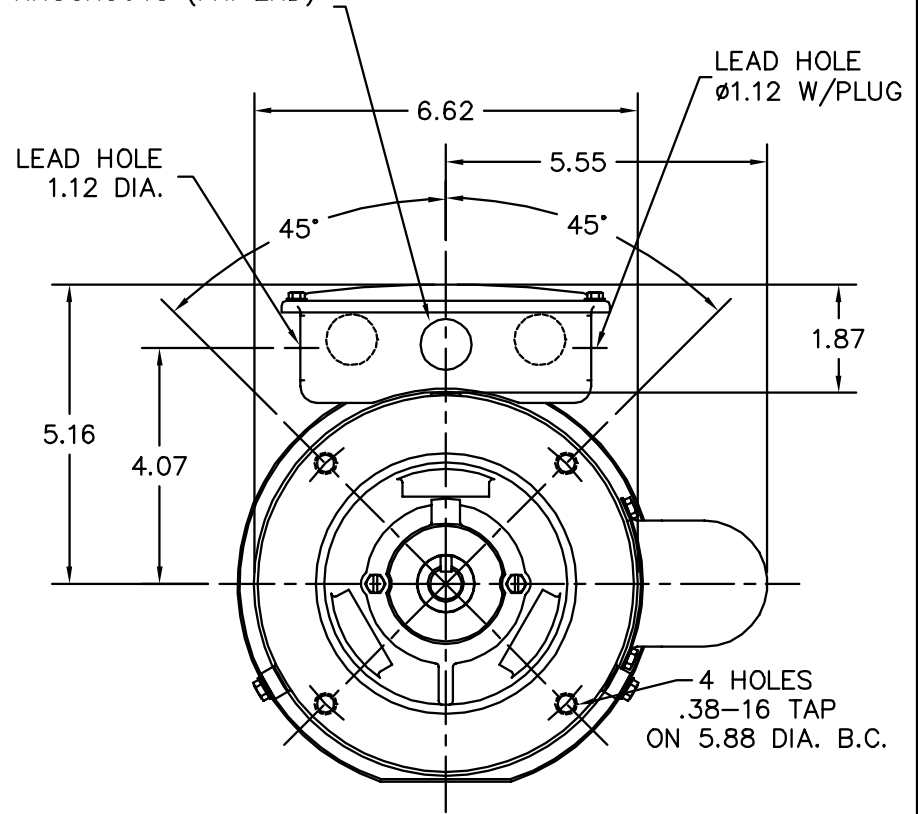
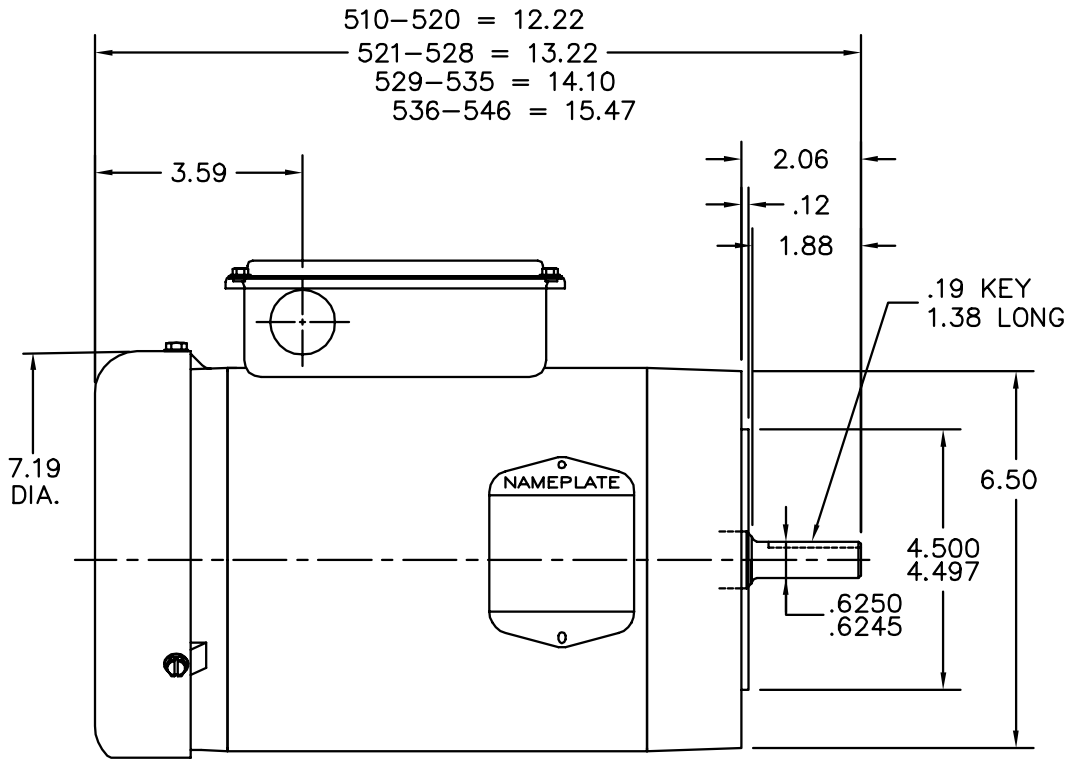

CUSTOMER IS RESPONSIBLE FOR DETERMINING THAT MOTOR PERFORMANCE IS SUITABLE IN THE APPLICATION.

REV. DESC: NEW		VERSION: 00		TDR: 000000448460	
REV. LTR: -		FILE: \AAA\00152\757		REVISED: 15: 40: 00 12/03/2007	
Z90X179C		MTL: -		BY: ENALEM0	

BALDOR • DODGE • RELIANCE

VER 56C TEFC 35L F3 CAP @3, W/35CB4007 @ 12