

INDEX	SAS001195
REV. LEVEL	1
SHEET	1 OF 1

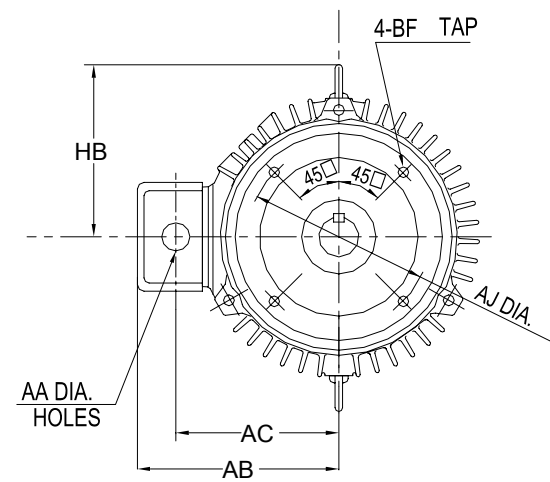
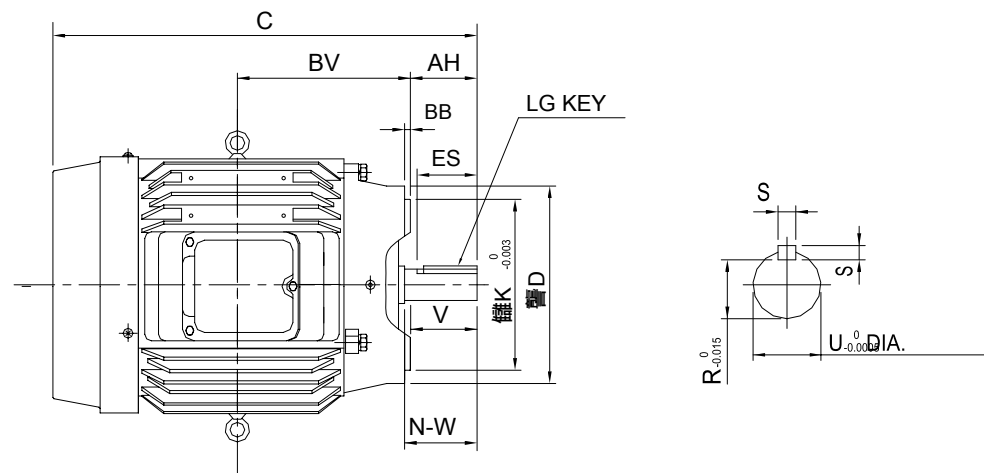

UNITS: INCHES

FRAME SIZE	FLANGE						
	AH	AJ	AK	BB	BD	BF TAP	BV
213T	3.12	7.250	8.500	0.25	9.00	1/2"-13UNC	6.51
215T	3.12	7.250	8.500	0.25	9.00	1/2"-13UNC	7.26

FRAME SIZE	MOTOR DIMENSIONS		CONDUIT BOX		
	C	HB	AA	AB	AC
213T	17.76	7.24	1.38	8.4	7.2
215T	19.26	7.24	1.38	8.4	7.2

FRAME SIZE	SHAFT EXTENSION			KEY SEAT			BEARINGS		MAXIMUM WEIGHT
	N-W	V	U	R	S	ES	LS	OS	
213T/215T	3.38	3.12	1.375	1.201	0.312	2.41	6308ZZ	6208ZZ	180 lbs.

CERTIFIED DATA

ALL DATA SUBJECT TO CHANGE WITHOUT NOTICE FOR CONSTRUCTION USE ONLY CERTIFIED DATA

NOTES:

1. DIMENSION V REPRESENTS LENGTH OF STRAIGHT PART OF SHAFT
2. CONDUIT BOX MAY BE ROTATED IN 90° INCREMENTS AND MAY BE MOUNTED ON OPPOSITE SIDE ON SPECIAL ORDER.
3. KEY DIMENSIONS EQUAL S x S x 2.41 (MOTOR SUPPLIED WITH KEY)
4. MOTOR WEIGHT SHOWN IS MAXIMUM HORSEPOWER IN FRAME.

CUSTOMER: _____ P.O. NO.: _____ TAG NO.: _____
 MOTOR MODEL NO.: Y754FTSA24A-P TOSHIBA FILE NO.: _____
 HP: 7.5 RPM (SYN.): 1800 VOLTAGE: 230/460 Hz: 60
 FRAME SIZE: 213TC LOG NO.: _____ LOG REV. LEVEL: _____
 REMARKS: _____
 PER: _____ ISSUE DATE: _____ SUPERSEDES: _____

TOSHIBA/HOUSTON
 TOTALLY-ENCLOSED
 FAN-COOLED
 WITH C-FACE FLANGE
 Fr. 213T-215T

TOSHIBA INTERNATIONAL CORPORATION
Industrial Division / Houston Motor Plant

**SQUIRREL CAGE INDUCTION MOTOR
 PERFORMANCE SPECIFICATIONS**

INDEX	MPCF-1033
SHEET NO.	1 of 1
ISSUED	11/08/96
SUPERSEDES	10/06/95
REVISION	1
WRITTEN BY	R. EVANS
APPROVED BY	<i>Jay Bugbee</i>

Customer Tag:

CUSTOMER:
 TIC SR No.:
 Customer PO:

MOTOR NAMEPLATE DATA

H.P.: 7.5	VOLTS: 230/460	3 Ø / 60	Hz	S. RPM: 1800
FRAME: 213TC	ENCL: TEFC	FLAMPS: 18.90/9.45		FLRPM: 1760
FORM: FCKL1	S.F.: 1.15	NEMA DESIGN: B		INSUL CLASS: F
TYPE: IKK	AMB.: 40	CODE: H		DUTY: CONT.
MODEL No.: Y754FTSA24A-P		kW:		Serial No.:
NOM. EFF.:	MIN. EFF.: 87.5	P.F.: 83.5		

AMPERAGE Locked Rotor: 63.5	TORQUES FULL LOAD (lb-ft.): 22.3 LOCKED ROTOR (%): 210 BREAK DOWN (%): 270	** BEARINGS: Drive End: 6308ZZ Opposite Drive End: 6208ZZ
---------------------------------------	--	--

EFFICIENCY (%) FULL LOAD: 89.5 3/4 LOAD: 90.0 1/2 LOAD: 89.5	POWER FACTOR (%) FULL LOAD: 83.5 3/4 LOAD: 80.0 1/2 LOAD: 70.0
--	--

ALL CHARACTERISTICS ARE AVERAGE EXPECTED VALUES BASED UPON RATED VOLTAGE, FREQUENCY AND SINEWAVE POWER INPUT.

* TEMPERATURE RISE WILL BE CONSISTENT WITH INSULATION, AMBIENT AND SERVICE FACTOR AS DEFINED BY NEMA-MG-12.43 OR -20.40.

** BEARINGS ARE THE ONLY RECOMMENDED SPARE PART(S).

CERTIFIED BY:
DATE:

TOSHIBA

Reliability in Motion

TOSHIBA INTERNATIONAL CORPORATION

INDUSTRIAL DIVISION

PO BOX 40906

HOUSTON TX 77240

(713) 466-0277

(800) 231-1412

FAX (713) 466-8773

SPARE PARTS (RECOMMENDED)

OTHER THAN THE GREASE USED FOR RE-GREASABLE BEARINGS, **TOSHIBA** ADVISES THAT THERE ARE NO "USE" PARTS. THE ONLY INSURANCE SPARES THAT **TOSHIBA** SUGGESTS FOR THESE SQUIRREL CAGE INDUCTION MOTORS ARE INDUSTRY STANDARD, AND COMMERCIALY AVAILABLE ANTI-FRICTION BEARINGS, AS NOTED BELOW.

MOTOR COMPONENTS (SUCH AS TERMINAL BOXES, FAN COVERS, MACHINED PARTS) ARE AVAILABLE UPON SPECIAL REQUEST. IN THIS CASE, PLEASE ADVISE OUR ORDER ENTRY DEPARTMENT THE MODEL AND SERIAL NUMBERS (FOUND ON THE MOTOR NAMEPLATE) , AND A DESCRIPTION OF THE COMPONENT REQUIRED. THEY WILL THEN FURNISH THE CURRENT PART NUMBER, PRICE AND AVAILABILITY.

(NOTE: OUR INTERNAL PART NUMBERS ARE SUBJECT TO CHANGE WITHOUT NOTICE, AND ARE NOT PUBLISHED).

PLEASE ADVISE IF YOU HAVE ANY QUESTIONS.

CUSTOMER:
PURCHASE ORDER #
Customer Tag:

TOSHIBA FILE #
MODEL # Y754FTSA24A-P
HP / RPM / ENCL / FRAME: 7.5 / 1800 / TEFC / 213TC
DRIVE END BEARING: 6308ZZ
OPPOSITE DRIVE END BEARING: 6208ZZ

Prepared By:
Date:

Three Phase Motor Wiring Diagram
"Across The Line" (Full Voltage) Starting

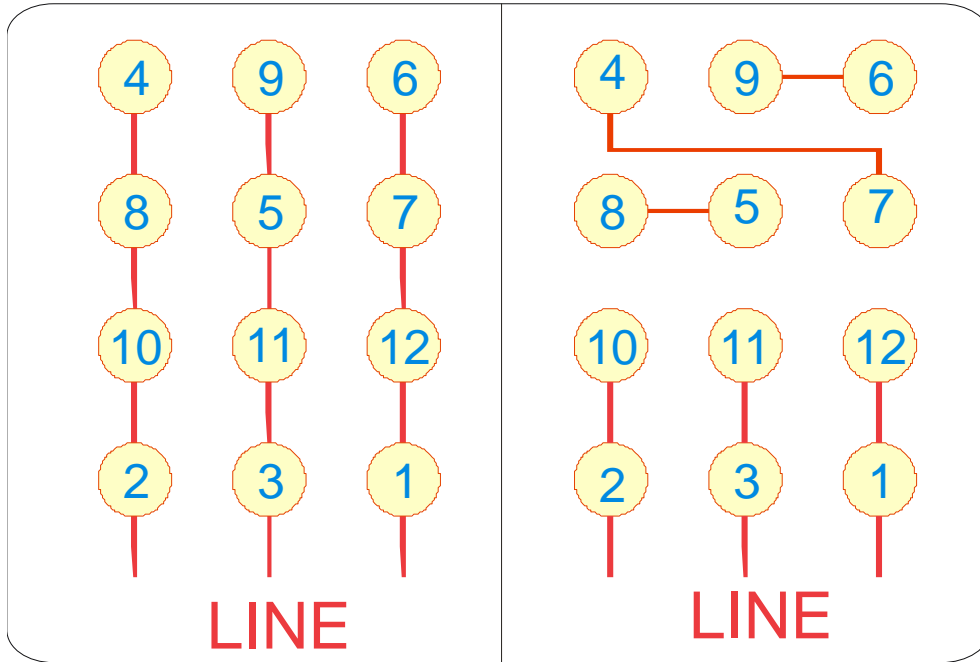

Customer Name:	
PO No.:	
Customer Tag:	
TIC File No.:	
Motor Model No. Y754FTSA24A-P	

For Further Information Regarding Toshiba motor starting, maintenance or wiring,
Please refer to the "Toshiba - A Quality Product for World Energy" Installation and
Maintenance Manual, or contact the Toshiba Low Voltage Motor Marketing Department.
(800) 231-1412

Prepared By:
Date: