

DATA SHEET

Three Phase Induction Motor-Squirrel Cage



Cusrtomer

Product line:

Product code:

Frame	:	256TC	Cooling method	:	TEFC
Insulation class	:	F	Mounting	:	F-1
Duty cycle	:	Cont.(S1)	Ratation	:	Both(CW and CCW)
Ambient temperature	:	-15°C to +40°C	Starting Method	:	Direct On Line
Altitude	:	1000m.a.s.l.	Approx. weight(lb)	:	
Design	:	B	Momet of inertia(J)	:	

Output [HP]	20		
Poles	2		
Frequency [Hz]	60		
Rated voltage [V]	230/460		
Rated current [A]	45.73/22.87		
L.R. Amperes [A]	315/157.5		
LRC [A]	6.6		
No load current [A]	5.17		
Rated speed [RPM]	3560		
Slip [%]	1.11		
Rated torque [ft.lb]	29.5		
Locked rotor torque [%]	180		
Breakdown torque [%]	220		
Service factor	1		
Temperature rise	≤80K		
Locked rotor time	≤8s		
Noise level			
Efficiency	25%	82.26	
	50%	89.16	
	75%	90.9	
	100%	91.0	
Power Factor	25%	0.77	
	50%	0.87	
	75%	0.90	
	100%	0.90	

	<u>Drive end</u>	<u>Non drive end</u>
Bearing type	6309	6309
Sealing	Without	Without
	Bearing Seal	Bearing Seal
Lubrication interval	0h	0h
Lubricant amount	0g	0g
Lubricant type	None	

Notes

<p>This revision replaces and cancel the previous one, which must be eliminated. (1) Looking the motor from the shaft end. (2) Measure at 1m and with tolerance of +3dB(A) (3) Approximate weight subject to changes after manufacturing process. (4)At 100% of full load.</p>	<p>These are average values based on tests with power supply, subject to the tolerance stipulated in NEMA MG-1</p>
--	--

Rev.	Changes Summary	Performed	Checked	Date
Performed by				
Checked by			Page	Revision
Date	2024.02.17			

LOAD PERFORMANCE CURVE
Three Phase Induction Motor-Squirrel Cage

Cusrtomer

Product line:

Product code:

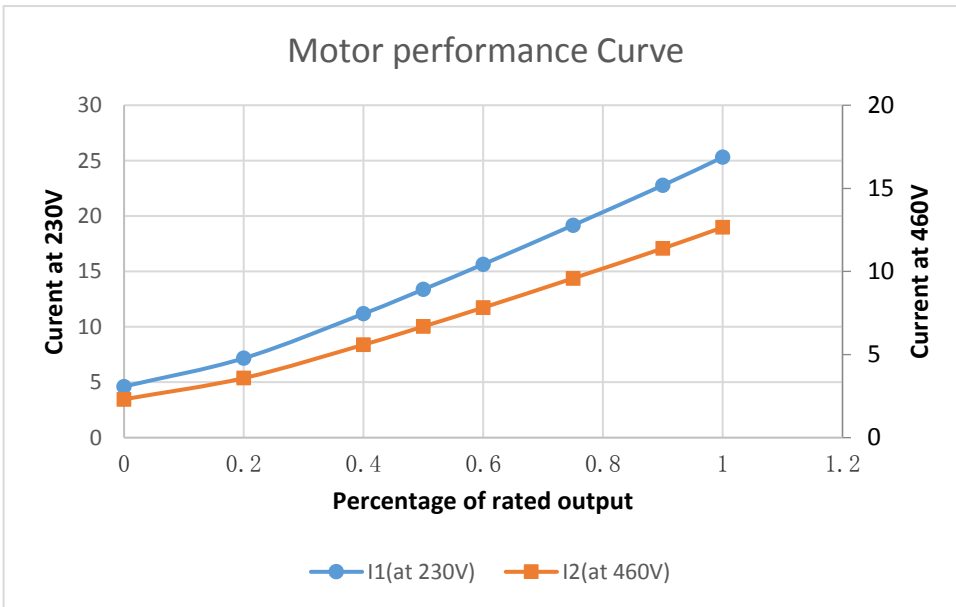
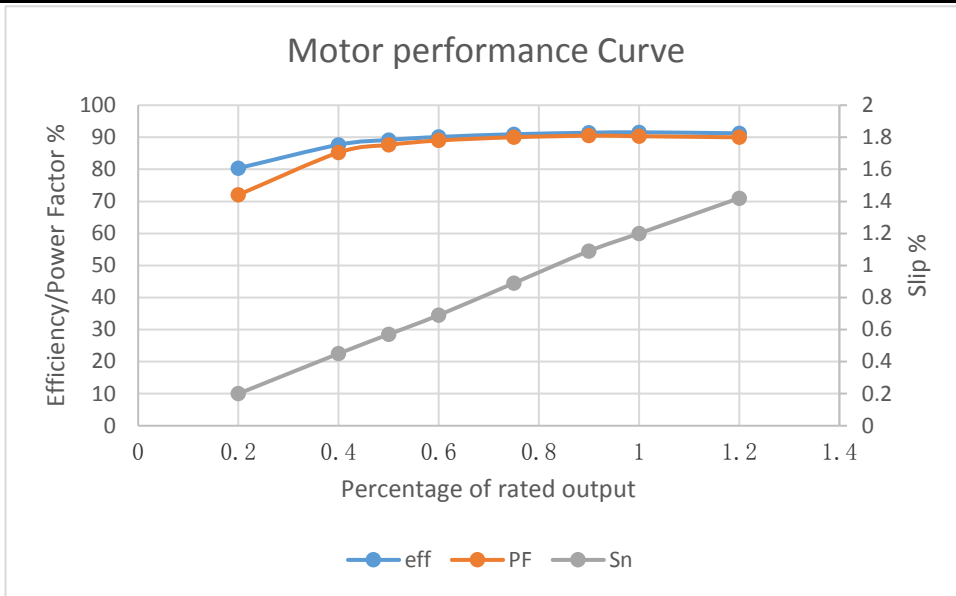

Permane	:	230/460V 60Hz		
Rated Current(A)	:	45.73/22.87	Moment of inertia(J)	:
LRC	:	6.6	Duty cycle	:
Rated Torque(lb-ft)	:	29.5	Insulation class	:
Locked rotor torque%	:	180	Service factor	:
Breakdown torque%	:	220	Temperature rise	:
Rated speed (r/min)	:	3560	Design	:
				S1
				F
				1
				80K
				B

This revision replaces and cancel the previous one, which must be eliminated.

These are average values based on tests with power supply, subject to the tolerance stipulated in NEMA

Rev.	Changes Summary	Performed	Checked	Date
Performed by			Page	Revision
Checked by				
Date	2024.02.17			



Nameplate Specification

Model	256TC-2	Frame	:256TC
Enclosure	:TEF C	Output HP	:20
Protection	:IP55	Phase	:3
Duty	:Continuous	Volts	:230/460V
Insulation Class	:F	NEMA DESIGN	:B
Rated Current	:45.73/22.87A	Service Factor	:1.0
Max ambient	:40°C	Speed	:3560
Code	:G	DE Bearing	:6309
Connection	:2 Δ / Δ	ODE Bearing	:6309
Power Factor	:0.90	Frequency	:60Hz
Nominal Efficiency	:91.0%	CSA	:Y
Min. Efficiency	:89.5%		

Technical Specification

Electrical Type	:Squirrel cage induction run	Starting Method	:Direct on line
Poles	:2	Rotation	:CW or CCW
Resistance	:0.55 Ω	Mounting	:Rigid Base
Motor Orientation	:Horizontal	Drive end Bearing	:Ball 6309
ODE Bearing	:Ball 6309	Frame Material	:Steel
C-face Diameter	:10 inch	Overall Length	:25.4 inch
Shaft Extension	:4 inch	Shaft Diameter	:1.625 inch
Shaft Extension Mate	:45# steel	Bearing Grease type	:2# Lithium Grease

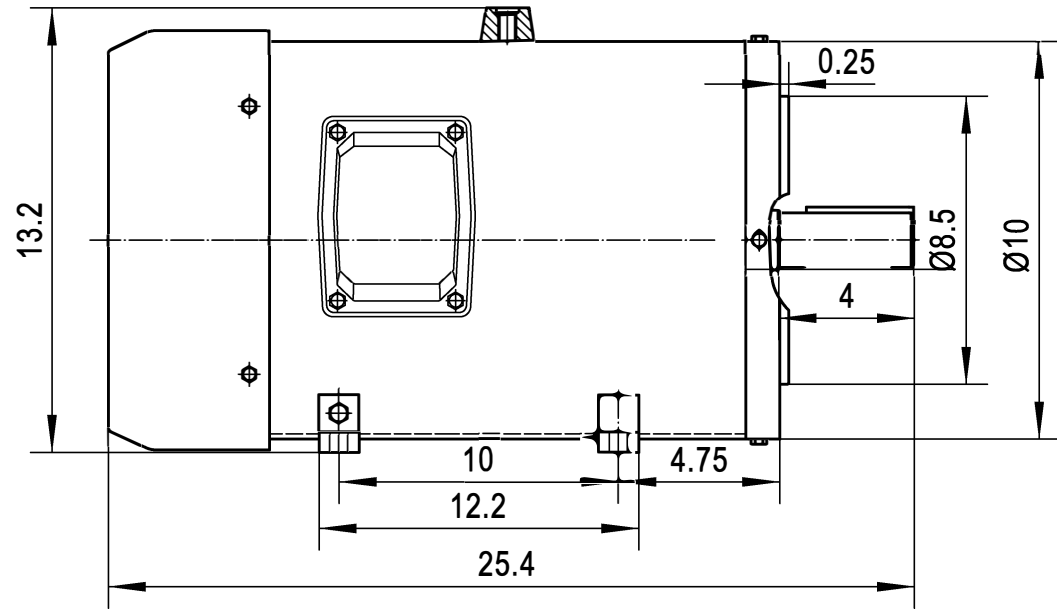
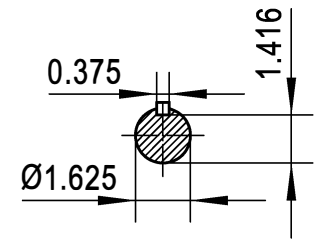
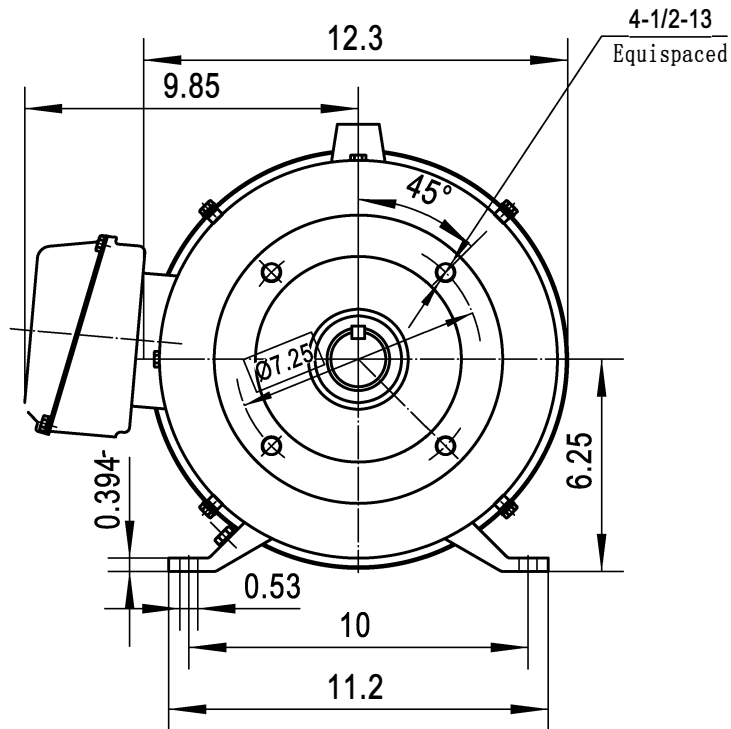

Dimensions in inches

Type	Power (HP)	Rated voltage (V)		Frequency (Hz)	Speed (r/min)	Eff (%)	Power Factor cos ϕ	Conn
		230 V	460 V					
256TC-2	20	Current (A)		60	3560	91.0	0.90	2 Δ / Δ
		45.73 A	22.87 A					

Frame	Cable Entry Size (inch)	Threaded cap Size (inch)
56-140	Ø1.00	Ø0.96
140-210	Ø1.18	Ø1.14
250	Ø1.44	Ø1.4
280	Ø1.77	Ø1.7

Borrowing (General) Parts Registration
 General Number of Old Base Map
 Base figure total number
 Sign
 Date
 filer date

sign	Change File Name	Sign	Date				256TC-2 (F. TEFC)
Design	Standardization	Pattern marking	Weight	Proportion			
Check	Verification			1:4			
To examine	Approval	common	Zhang	The first	Zhang		
Technology	Date						