



Product Information Packet

April 11, 2025

Data shown is for the current revision model #. Ensure your nameplate model # matches.

Model Number:	WPN-DF225MF-6
Catalog Number:	BC6M040V4
Connection Diagram:	See Page 4
Outline Drawing:	See Page 3

Table of Contents	
Specification	01
Performance Characteristics	02
Outline Drawing	03
Connection Drawing(s)	04

Marks:

MODEL NUMBER:	BC6M040V4	Estimated Weight:	1050Lbs
Outline Drawing:	See Page 3	Time Rating:	S1
Connection Diagram:	See Page 4	Enclosure:	TEFC
Design Code:	B	Encl Construction:	GP
Type:	KS	Ambient Max(°C):	40
Frame:	225M	Alt Ambient Max(°C):	40
Phases:	3	Insulation Class:	F
Poles:	6	NEMA Design:	B
Output Power:	40HP	Nominal Efficiency:	94.1 %
RPM:	1185	Guaranteed Efficiency:	93.0 %
Voltage:	208-230/460	3/4 Load Efficiency:	94.3%
Hertz:	60	KVA Code:	G
Amps - FL:	93.1/46.5	Max KVAR:	6.3
Service Factor:	1.25@60Hz	Power Factor:	86%
Alt Service Factor:	1.15	Bearing - DE:	6316-C3
		Bearing - ODE:	6314-C3

Enclosure is Totally Enclosed Fan-Cooled

Stamped Nameplate Notes:

12-60HZ CONSTANT TORQUE, 6-60Hz VARIABLE TORQUE

50HZ DATA:
 190-200/400V
 108/54.2AMPS
 RPM 985
 SF 1.0

CSA APPROVED FOR CLASS I;DIVISION 2; GROUPS A, B, C & D,ZONE 2; GROUPS IIA & IIB T3 WITH VFD

Additional Information:

F1/F2/F3/ROUND BODY MOUNTING USING REMOVABLE/REPOSITIONABLE FEET
 INVERTER DUTY: CT5:1(12Hz~60Hz)@100%TN, CT15:1(4Hz~60Hz)@66.7%TN, VT20:1

Performance Characteristics

Marks:

LOAD %	150.0	125.0	100.0	75.0	50.0	25.0
% EFF	93.0	93.7	94.1	94.3	93.9	91.7
% PF	86.3	83.7	83.3	80.6	73.2	52.3
AMPS(460V)	70.4	60.0	48.0	37.2	27.4	19.6

TORQUE(FL) LB-FT 242 TORQUE(LR)%FL 140 TORQUE(BD)%FL 236
 AMPS(LR 460V) 276 PF AT START 25

Other Useful Information for Application:

Rotor Inertia: Lb-Ft ² (Kg-m ²):	18.6(0.783)
Max load inertia: Lb-Ft ² (Kg-m ²):	
Load Type:	Square Torque/Speed Characteristic
Voltage:	100%
Number of starts per hour:	2 Cold or 1 Hot
Acceleration Time with maximum inertia (sec):	15
Safe stall time (sec): Cold/Hot	78/32

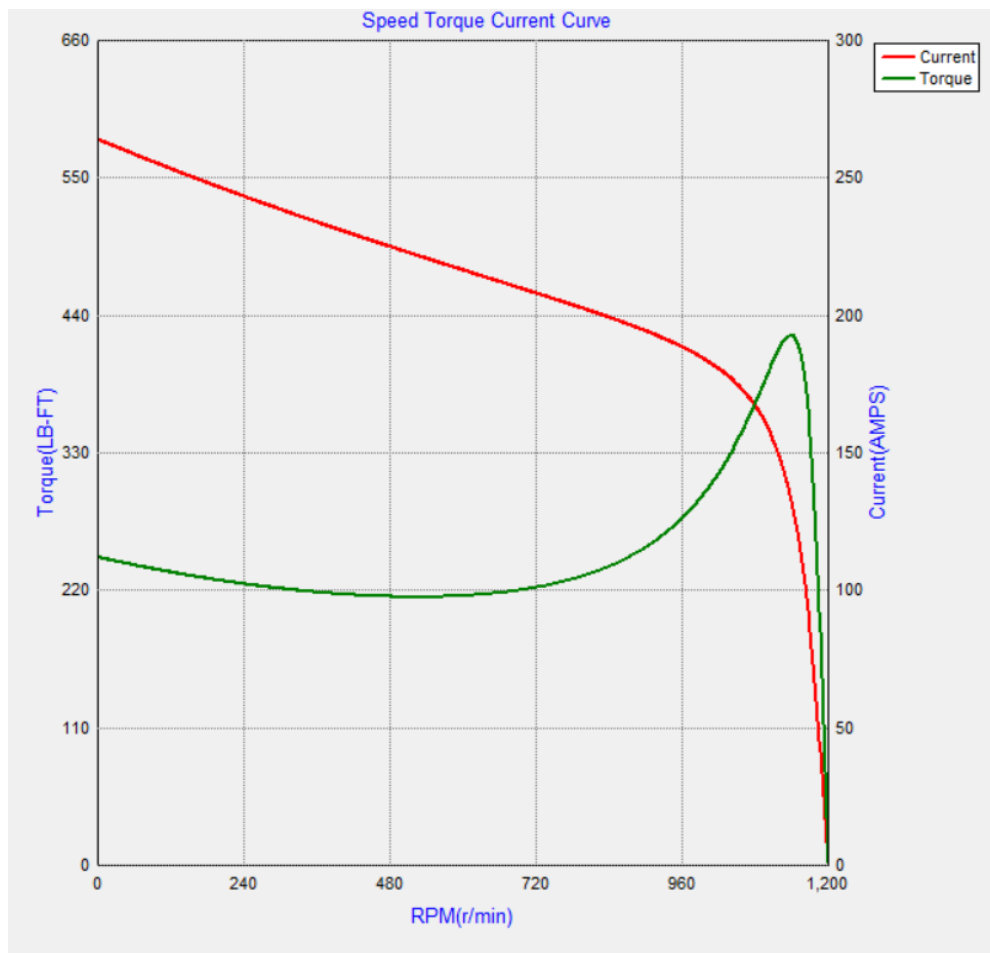

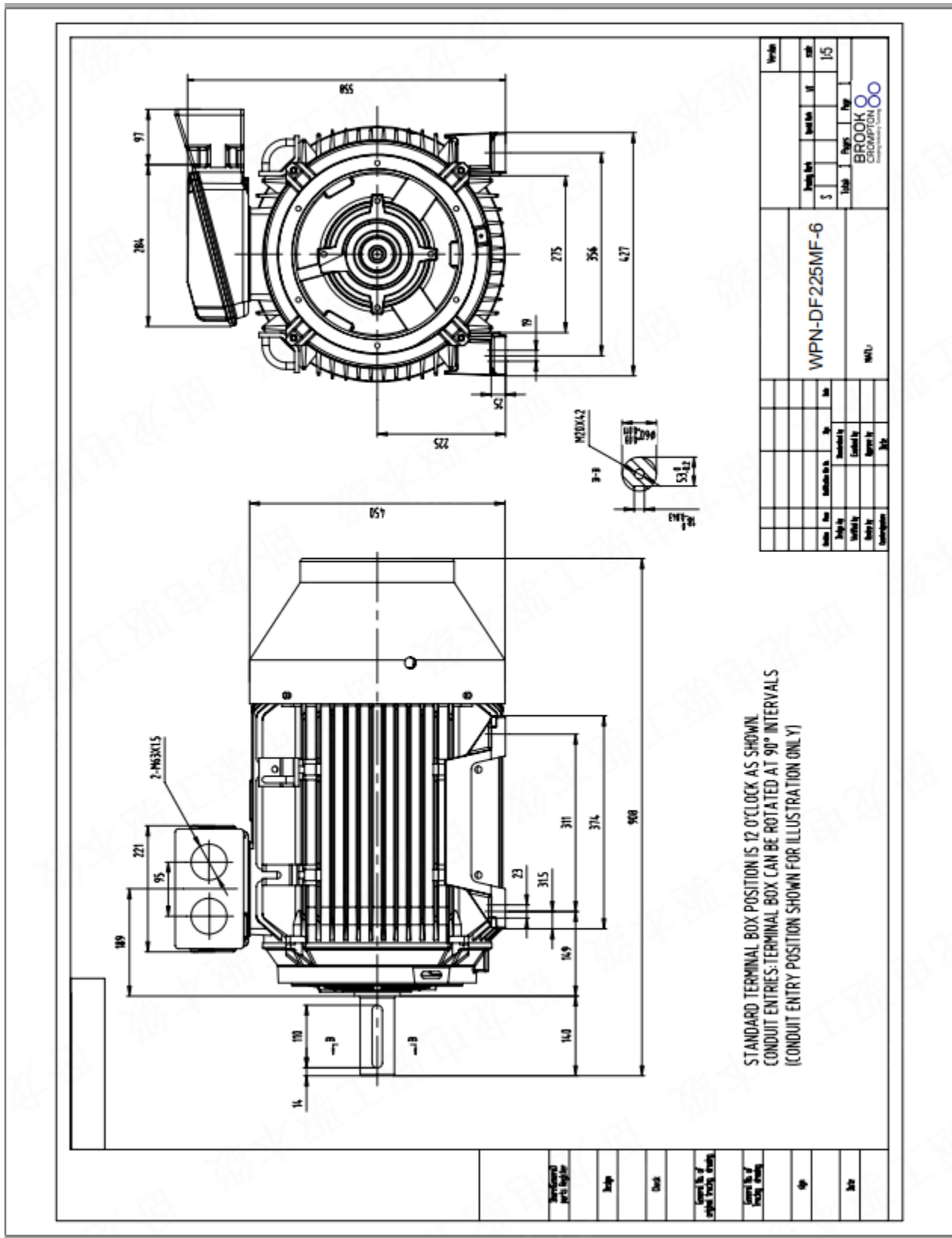

Title		WPN-DF225MF-6		Part No.		15	
Date		M20		Rev		15	
Drawn by		M20		Checked by		M20	
Designed by		M20		Approved by		M20	
Description		M20		Part		M20	
Scale		1:1		Sheet		15	
Total		3		Pages		15	
Part No.		M20		Rev		15	
Checked by		M20		Approved by		M20	
Description		M20		Part		M20	

Marks:

Connection Diagram

Thermistor Connection

