

SHEET 1
 REV 0
 SIZE DRAWING NO. A
 52A107632 0

THIRD ANGLE PROJECTION

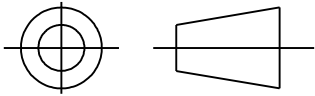

REVISIONS

REV.	DESCRIPTION	DATE	APPROVED
13	ADDED PART #7	03/16/07	MADHU
14	ADDED PART #8 AS PER DS07-0748	06/27/07	BOMMU
15	ADDED PART #9	05/27/08	DURGA
16	PT# 7 IS NOT USED YET - CHG RUN CAP DIMS & USED PER DS09-0872	06/03/09	PRAVEEN.K

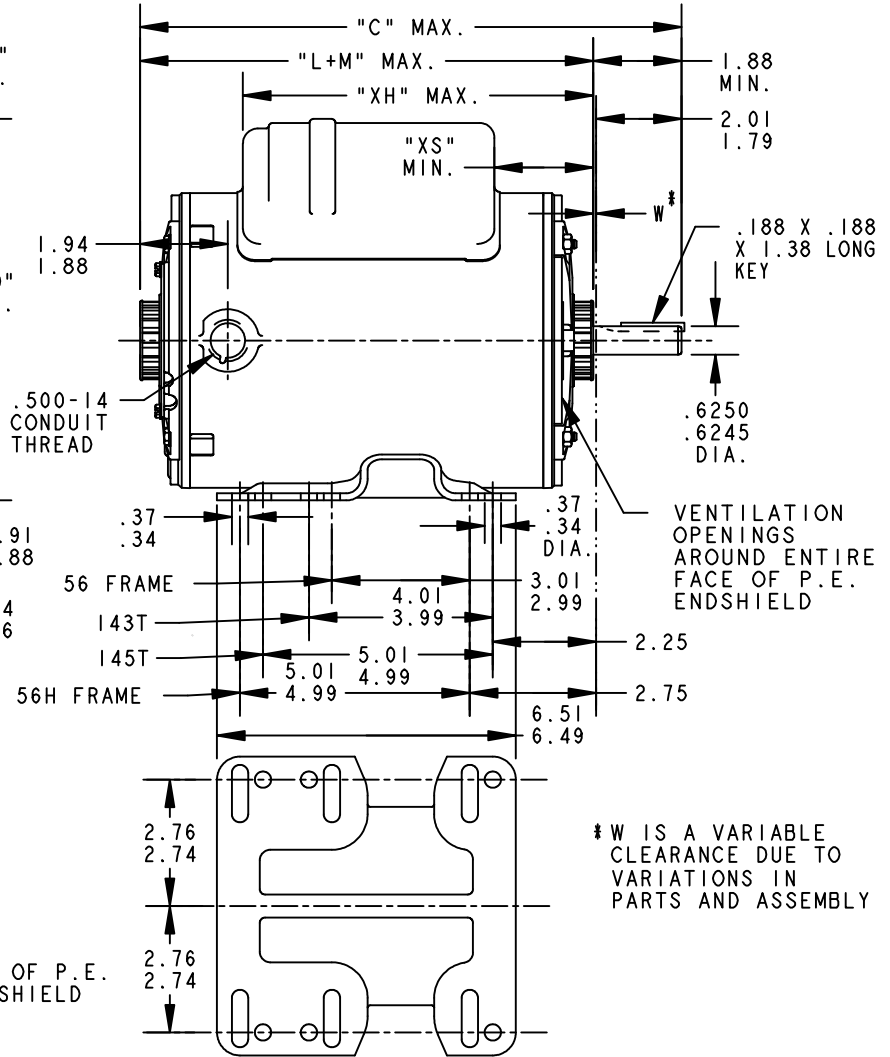
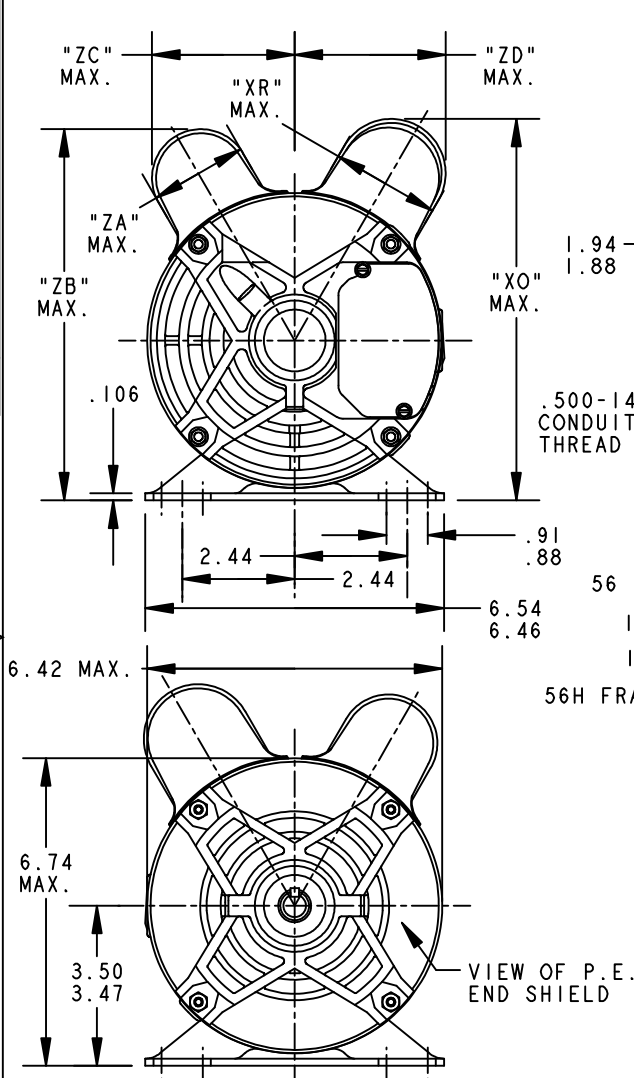

PART NUMBERS ARE ADDED IN SHEET 2

SIGNATURES	DATE
MODEL M.D.PAPE	10/24/90
DETAIL .	.
CHECKED .	.
ENGRG .	.
MFG .	.
QUALITY .	.
ISSUED M.D.PAPE	08/27/97
SOLID MODEL: 52A107632	



REGAL-BELOIT CORPORATION

TITLE
OUTLINE
40 FRAME REDESIGN - GENERAL PURPOSE MOTOR -
DRIP PROOF - BALL BEARING - WELDED BASE

SIZE DRAWING
52A107632 REV
A **0**

SCALE: 0.250 REF. No: . SHEET 1 of 2

↓

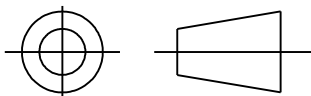
SHEET 2	THIRD ANGLE PROJECTION	REVISIONS			
		REV.	DESCRIPTION	DATE	APPROVED
REV 52A107632		13	ADDED PART #7	03/16/07	MADHU
		14	ADDED PART #8 AS PER DS07-0748	06/27/07	BOMMU
		15	ADDED PART #9	05/27/08	DURGA
		16	PT# 7 IS NOT USED YET - CHG RUN CAP DIMS & USED PER DS09-0872	06/03/09	PRAVEEN.K

↓

SIZE DRAWING NO.
A

9	KCR	48	56H	12.66	10.76	7.71	8.11	2.10	2.12	2.10	8.11	3.12	3.12	8.43
8	KCR	48	56H	12.66	10.76	8.46	8.40	2.40	2.87	2.15	8.15	3.12	3.38	8.43
7	KCR	48	56H	12.66	10.76	7.71	8.11	2.10	2.12	2.40	8.40	3.38	3.12	8.43
6	KCR	49	56H	15.04	13.04	9.74	7.38	1.60	4.05	2.10	8.16	2.94	2.59	10.71
5	KCR	49	56H	13.22	11.32	8.32	7.38	1.60	2.57	2.15	8.18	3.20	2.59	8.99
4	KCR	49	56H	13.86	11.96	10.40	8.40	2.40	4.92	2.40	8.40	3.38	3.38	9.63
3	KCR	48	56H	12.66	10.76	7.76	8.77	2.72	2.01	2.15	8.18	3.20	3.38	8.43
2	KCR	49	56H	14.94	13.04	9.74	8.40	2.40	4.05	2.15	8.18	3.20	3.38	10.71
1	KCR	49	56H	11.91	10.01	7.76	8.40	2.40	2.01	2.15	8.18	3.20	3.38	7.68
P	TYPE	RBC SIZE	NEMA FR	"C"	"L+M"	"XH"	"XO"	"XR"	"XS"	"ZA"	"ZB"	"ZC"	"ZD"	MTN. SHELL

FOR ADDITIONAL INFO REFER TO: APPLIED PRACTICES DIMENSIONS ARE IN INCHES ✓ MATERIAL	SIGNATURES	DATE	 REGAL-BELOIT CORPORATION	
	MODEL	M.D.PAPE		10/24/90
	DETAIL	.		.
	CHECKED	.		.
	ENGRG	.		.
MFG	.	.	TITLE OUTLINE 40 FRAME REDESIGN - GENERAL PURPOSE MOTOR - DRIP PROOF - BALL BEARING - WELDED BASE	
QUALITY	.	.		
ISSUED	M.D.PAPE	08/27/97		
SIZE DRAWING		52A107632		
SCALE: 0.250		REF. No: .		
			SHEET 2 of 2	